



Data sheet

# ELIMINATOR® Hermetic burn-out filter drier Type DAS



ELIMINATOR® Hermetic burn-out filter driers type DAS are used in the suction line to clean up refrigeration and air conditioning systems after a compressor motor burn-out.

The solid core, which is composed of 70% activated alumina and 30% Molecular Sieve, adsorbs harmful acids as well as moisture.

Available with flare and solder (pure copper) connections.

**Features**

**The Core type DAS**

- Solid core with 70% activated alumina and 30% Molecular Sieve for adsorption of acid and moisture
- Recommended for use with HFO, HC, HFC and HCFC refrigerants

**The Shell**

- UL approved for MWP 500 psig
- Available with flare and solder (pure copper) connections

- Corrosion resistant powder-painted finish
- Allows installation with any orientation provided the flow is in the arrow direction
- 2 Schrader access valves to measure pressure drop across the drier
- Available in sizes 8 — 60 cubic inches

**The Filter**

- 120 mesh wire mesh provides solid particle retention with minimal pressure drop

**Approvals**

UL file no. SA 6398  
PED 97/23/EC - a3p3

Compliant with ATEX hazard zone 2

**Note:** Only solder versions (cu-plated/pure copper) and connection sizes below 25mm are approved for flammable refrigerants now.

**Introduction**

ELIMINATOR® Hermetic filter driers protect refrigeration and air-conditioning systems from moisture, acids, and solid particles.

By adsorbing harmful acids after a compressor motor damage, the DAS hermetic burn-out filter drier protects the new compressor against premature failure.

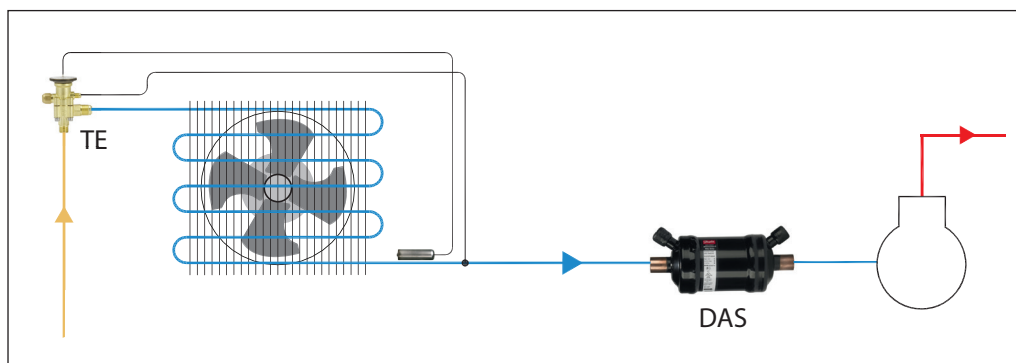

**Technical data and capacities**

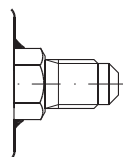

Flare connection

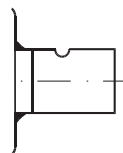

Solder connection (pure copper)

Type	Rated capacity, $Q_n$ <sup>1)</sup>			Acid capacity <sup>2)</sup>	Max. Working Pressure MWP [psig]
	R22/R407C/R410A	R134a	R404A/R507		
	[TR]	[TR]	[TR]	[oz.]	
DAS 083	1.7	1.0	1.3	0.13	500
DAS 084	2.9	1.6	2.3	0.13	500
DAS 085	4.1	2.6	3.6	0.13	500
DAS 086	5.4	3.3	4.7	0.13	500
DAS 164	6.3	1.7	2.4	0.30	500
DAS 165	4.3	2.7	3.7	0.30	500
DAS 166	5.7	3.4	4.9	0.30	500
DAS 167	6.3	3.9	5.4	0.30	500
DAS 305	5.1	3.1	4.3	0.64	500
DAS 306	6.3	4.0	5.4	0.64	500
DAS 307	7.4	4.6	6.3	0.64	500
DAS 309	8.9	5.7	7.7	0.64	500
DAS 417	8.6	5.1	7.1	0.86	500
DAS 419	10.0	6.3	8.6	0.86	500
DAS 607	5.7	3.4	4.9	1.29	500

1) Rated capacity is stated at: evaporating temperature  $t_e = 39.2$  °F pressure drop  $\Delta p = 3.04$  psig

2) Adsorption capacity of oleic acid at 0.05 TAN (Total Acid Number).

Temperature range:  
-40 – 160 °F

**Selection**

Capacities for other temperatures than 39.2 °F are calculated by use of correction factors. Divide your actual evaporator capacity with the correction factor given for your actual evaporating temperature.

Look up the capacity table for the necessary rated capacity.

$$Q_e / F_e = Q_n$$

- $Q_e$  = Actual evaporator capacity
- $Q_n$  = Nominal capacity
- $F_e$  = Correction factor

Correction factors.  $F_e$  evaporating temperatures [°F]

[°F]	39.2	32	23	14	5	-4	-13	-22	-31	-40
$F_e$	1	0.9	0.75	0.6	0.5	0.4	0.35	0.25	0.2	0.15

*Example*

To select a hermetic burn-out filter drier for a R22 plant with an evaporator capacity at 2.41 TR at -4 °F you may use a burn-out filter drier with a rated capacity of  $8.5/0.4 = 6.02$  TR or bigger. For example DAS 306.

**Ordering**

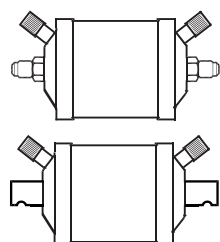

*Flare*

Type	Connection	Multi pack	
	[in.]	Qty.	Code no.
DAS 083VV	3/8	24	023Z1001
DAS 084VV	1/2	24	023Z1002
DAS 164VV	1/2	12	023Z1007
DAS 165VV	5/8	12	023Z1008

*Solder*

Type	Connection	Multi pack	
	[in.]	Qty.	Code no.
DAS 083sVV	3/8	24	023Z1003
DAS 084sVV	1/2	24	023Z1004
DAS 085sVV	5/8	24	023Z1005
DAS 086sVV	3/4	24	023Z1006
DAS 164sVV	1/2	12	023Z1009
DAS 165sVV	5/8	12	023Z1010
DAS 166sVV	3/4	12	023Z1011
DAS 167sVV	7/8	12	023Z1012
DAS 305sVV	5/8	8	023Z1013
DAS 306sVV	3/4	8	023Z1014
DAS 307sVV	7/8	8	023Z1015
DAS 309sVV	1 1/8	8	023Z1016
DAS 417sVV	7/8	8	023Z1017
DAS 419sVV	1 1/8	8	023Z1018
DAS 607sVV	7/8	12	023Z1019
DAS 609sVV	1 1/8	12	023Z1020

Identification

Type codes

<b>Filter drier</b>	<b>D</b>	Drier	
<b>Solid core</b>	<b>A</b>	Burn-out, 70% activated alumina / 30% Molecular Sieves	
<b>Application</b>	<b>S</b>	Suction line	
<b>Size (volume)</b>	<b>08</b>	8 in <sup>3</sup>	
	<b>16</b>	16 in <sup>3</sup>	
	<b>30</b>	30 in <sup>3</sup>	
	<b>41</b>	41 in <sup>3</sup>	
	<b>60</b>	60 in <sup>3</sup>	
<b>Connection (filter connection in 1/8 of an inch increments)</b>	<b>3</b>	3/8 in. / 10 mm	
	<b>4</b>	1/2 in. / 12 mm	
	<b>5</b>	5/8 in. / 16 mm	
	<b>6</b>	3/4 in. / 18 (19) mm	
	<b>7</b>	7/8 in. / 22 mm	
	<b>9</b>	1 1/8 in. / 28 mm	
<b>Connection type</b>	<b>(blank)</b>	Flare connection	
	<b>s</b>	Solder connection (pure copper)	
<b>Access valves</b>		Inlet:	Outlet:
	<b>(blank)</b>	No access valves	No access valves
	<b>V</b>	Schrader valve	No access valves
	<b>VV</b>	Schrader valve	Schrader valve

Example for type codes

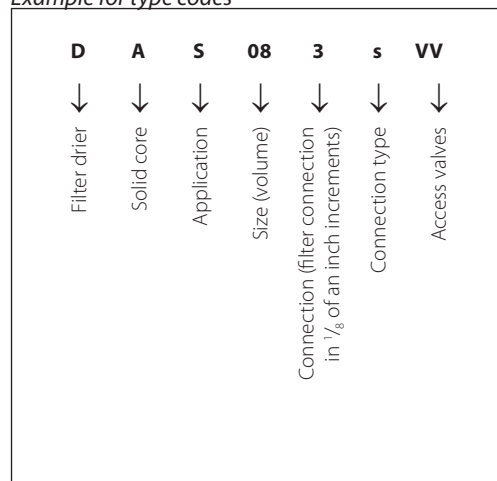

Design / function

- 1. Inlet
- 2. Spring
- 3. Solid core
- 4. Polyester mat
- 5. Metal mesh
- 6. Perforated plate
- 7. Schraeder valve

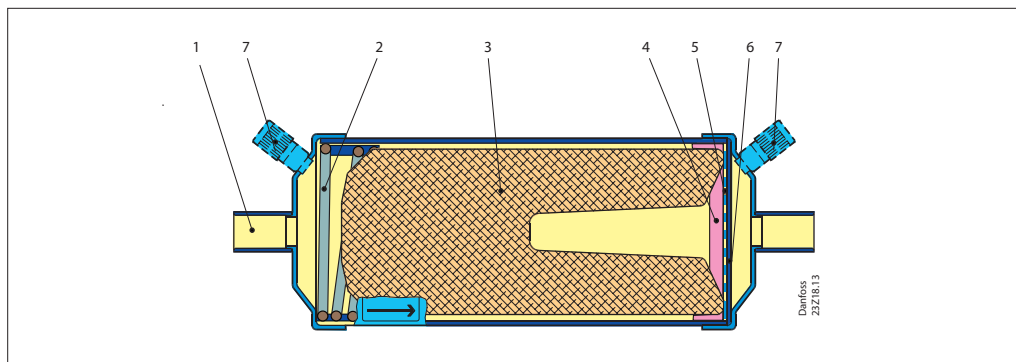

The large diameter of the hermetic burn-out filter drier means that flow velocity is suitably low and the pressure drop minimal.

Powder formation is eliminated because the solid core grains are bonded and cannot move against each other.

Dimensions [in.] and weights [lbs]

Solder connections

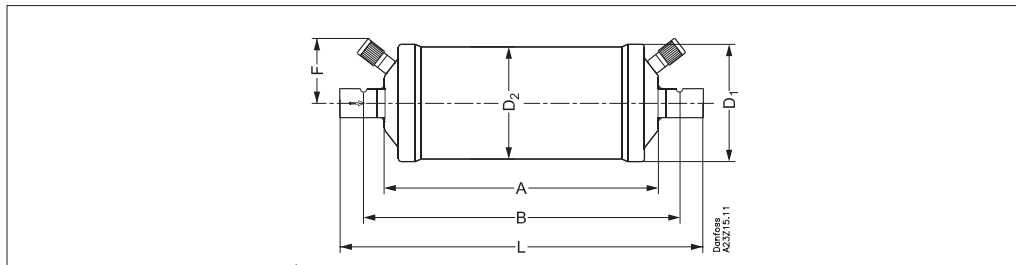

Type	A	B	L	D <sub>1</sub>	D <sub>2</sub>	F	Net weight
DAS 083sVV	4.0	4.7	5.5	2.3	2.1	1.6	1.00
DAS 084sVV	4.0	4.8	5.6	2.3	2.1	1.6	1.10
DAS 085sVV	4.0	4.9	5.9	2.3	2.1	1.6	1.10
DAS 086sVV	4.0	5.2	6.3	2.3	2.1	1.6	1.10
DAS 164sVV	4.3	5.2	6.0	3.1	3.0	2.0	2.03
DAS 165sVV	4.3	5.3	6.2	3.1	3.0	2.0	1.90
DAS 166sVV	4.3	5.5	6.7	3.1	3.0	2.0	1.90
DAS 167sVV	4.3	5.6	6.8	3.1	3.0	2.0	1.90
DAS 169sVV	4.3	5.6	6.8	3.1	3.0	2.0	0.84
DAS 305sVV	7.3	8.3	9.2	3.1	3.0	2.0	2.90
DAS 306sVV	7.3	8.5	9.7	3.1	3.0	2.0	2.90
DAS 307sVV	7.3	8.5	9.8	3.1	3.0	2.0	2.90
DAS 309sVV	7.3	8.5	9.8	3.1	3.0	2.0	3.00
DAS 417sVV	7.4	8.6	9.8	3.7	3.5	2.2	4.60
DAS 419sVV	7.4	8.6	9.8	3.7	3.5	2.2	4.60
DAS 607sVV	13.3	14.3	15.7	3.1	3.0	2.0	5.30
DAS 609sVV	13.3	14.1	15.7	3.1	3.0	2.0	5.30

**Dimensions [in.] and weights [lbs]**  
(continued)

Flare connections

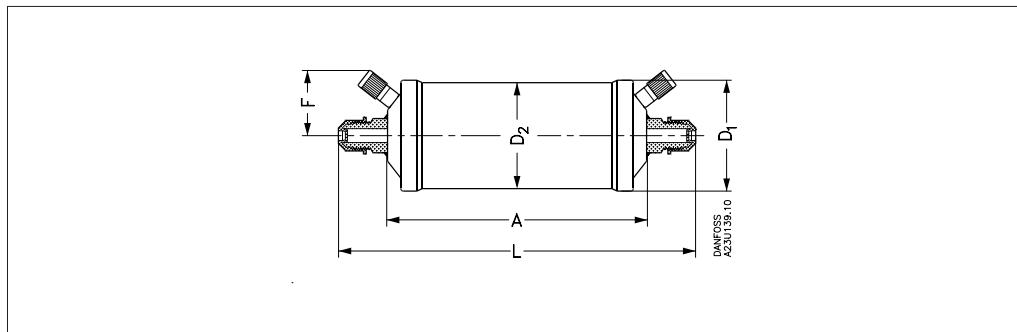

Type	A	L	D <sub>1</sub>	D <sub>2</sub>	F	Net weight
DAS 083VV	4.0	6.2	2.3	2.1	1.6	1.12
DAS 084VV	4.0	6.5	2.3	2.1	1.6	1.37
DAS 164VV	4.3	6.9	3.1	3.0	1.6	2.01
DAS 165VV	4.3	7.2	3.1	3.0	1.6	2.09

Danfoss can accept no responsibility for possible errors in catalogues, brochures and other printed material. Danfoss reserves the right to alter its products without notice. This also applies to products already on order provided that such alterations can be made without subsequential changes being necessary in specifications already agreed. All trademarks in this material are property of the respective companies. Danfoss and the Danfoss logotype are trademarks of Danfoss A/S. All rights reserved.