

Data sheet

Sight Glass for low pressure refrigerants

Type SG



Sight glasses are used to indicate:

1. The condition of the refrigerant in the liquid line of the plant.
2. The flow in the oil return line from the oil separator.
3. The moisture content in the refrigerant.

The SG and SGR are mainly used to indicate the condition of the refrigerant as well as the liquid level in the receiver or the oil level in the compressor.

The SGI/N and SGRI/N are equipped with sensitive indicators that reflect a colour, depending on the moisture content in the refrigerant.

Features

Type SG / SGR

- Indicates lack of subcooling
- Indicates refrigerant deficiency
- Indicates liquid level in receiver
- Indicates oil level in compressor
- Flare/solder connection or socket type







Type SGI / SGRI

- Refrigerants where lubrication is by mineral oil e.g. HCFC
- Indicates too high water content in the refrigeration system
- Indicates lack of subcooling
- Indicates refrigerant deficiency
- Flare/solder connection or socket type

Type SGN / SGRN

- For Non- flammable HFC refrigerants
- Indicates too high water content in the refrigeration system
- Indicates lack of subcooling
- Indicates refrigerant deficiency
- Flare/solder connection or socket type

Available types

SG: Without moisture indicator		SGR: Socket type without moisture indicator	
 Solder version	 Flare version	 Socket	
SGI: For mineral oil e.g. HCFC	SGN: With Non- flammable HFC moisture indicator	SGRI: Saddle sight glass for mineral oil e.g. HCFC	SGRN: Saddle sight glass with Non- flammable HFC moisture indicator
 Solder version	 Flare version	 Socket	 Saddle

Choice of sight glass

Before choosing a sight glass with moisture indicator, the following should be considered:

- type of refrigerant
- water solubility of refrigerant
- the level on which a danger signal is required.

Be aware that polyester oil for Non- flammable HFC refrigerants, e.g. R134a, R404A, R407C react with water in a hydrolysis generating acid and alcohol.

The recommended levels of moisture content are usually between 30 and 75 ppm, where hermetic compressors only tolerate very low moisture content, while semi-hermetic and other

compressors normally tolerate higher moisture contents in the refrigerant.

The color on the sight glass indicator depends on the moisture content of the refrigerant.

The values under "green/dry" are to be considered as perfect condition meaning full protection against harmful effects from moisture. In other words, the filter drier is working perfectly.

If the green color starts to fade, the color change has begun and the indicator should therefore be watched more carefully. If the color changes to yellow it is a clear signal that the capacity of the filter drier is exceeded and should be replaced as soon as possible.

Technical data

Ambient temperature
-50 – 80 °C / -58 – 75 °F

Max. working pressure
PS / MWP = 35 bar / 508 psig

SGI / SGRI for mineral oil e.g. HCFC refrigerants

	Moisture content ppm = parts per million					
	SGI / SGRI					
	25 °C			43 °C		
	Green/dry	Intermed. color	Yellow/wet	Green/dry	Intermed. color	Yellow/wet
Mineral oil e.g. R22	< 150	150 – 300	> 300	< 250	250 – 500	> 500

SGN / SGRN for HCFC and Non- flammable HFC refrigerants

	Moisture content ppm = parts per million					
	SGN / SGRN					
	25 °C			43 °C		
	Green/dry	Intermed. color	Yellow/wet	Green/dry	Intermed. color	Yellow/wet
R22	< 30	30 – 120	> 120	< 50	50 – 200	> 200
R134a	< 30	30 – 100	> 100	< 45	45 – 170	> 170
R404A	< 20	20 – 70	> 70	< 25	25 – 100	> 100
R407C	< 30	30 – 140	> 140	< 60	60 – 225	> 225
R507	< 15	15 – 60	> 60	< 30	30 – 110	> 110





Note:
For moisture values of other refrigerants, please contact Danfoss.

Ordering

Monitor

	Type	Version	Connection [in.]	Connection [mm]	Code no.
	SG 12	ODF × ODF solder	1/2 × 1/2	16 × 16	014-0086
	SG 16	ODF × ODF solder	5/8 × 5/8	16 × 16	014-0087





HCFC

	Type	Version	Connection [in.]	Connection [mm]	Code no.
	SGI 6	Flare ext. × ext.	1/4 × 1/4	6 × 6	014-0007
	SGI 10		3/8 × 3/8	10 × 10	014-0008
	SGI 12		1/2 × 1/2	12 × 12	014-0075
	SGI 16		5/8 × 5/8	16 × 16	014-0024
	SGI 19		3/4 × 3/4	19 × 19	014-0028
	SGI 6	Flare int. × ext. ¹⁾	1/4 × 1/4	6 × 6	014-0021
	SGI 10		3/8 × 3/8	10 × 10	014-0022
	SGI 12		1/2 × 1/2	12 × 12	014-0025
	SGI 16		5/8 × 5/8	16 × 16	014-0026
	SGI 19		3/4 × 3/4	19 × 19	014-0043
	SGI 6s	ODF × ODF solder	1/4 × 1/4	—	014-0034
	SGI 10s		3/8 × 3/8	—	014-0035
	SGI 12s		1/2 × 1/2	—	014-0036
	SGI 16s		5/8 × 5/8	16 × 16	014-0044
	SGI 19s		3/4 × 3/4	19 × 19	014-0047
	SGI 22s		7/8 × 7/8	22 × 22	014-0039
	SGI 6s	ODF × ODF solder	—	6 × 6	014-0040
	SGI 10s		—	10 × 10	014-0041
	SGI 12s		—	12 × 12	014-0042
	SGI 18s		—	18 × 18	014-0045
	SGI 6s	ODF × ODM solder	1/4 × 1/4	—	014-0125
	SGI 10s		3/8 × 3/8	—	014-0126
	SGI 12s		1/2 × 1/2	—	014-0127
	SGI 16s		5/8 × 5/8	16 × 16	014-0128
	SGI 22s		7/8 × 7/8	22 × 22	014-0130

¹⁾ Can be screwed directly into the filter drier.

Ordering
(continued)







HCFC and Non-flammable HFC

	Type	Version	Connection [in.]	Connection [mm]	Code no.	
	SGN 6	Flare ext. x ext.	$\frac{1}{4} \times \frac{1}{4}$	6 × 6	014-0161	
	SGN 10		$\frac{3}{8} \times \frac{3}{8}$	10 × 10	014-0162	
	SGN 12		$\frac{1}{2} \times \frac{1}{2}$	12 × 12	014-0163	
	SGN 16		$\frac{5}{8} \times \frac{5}{8}$	16 × 16	014-0165	
	SGN 19		$\frac{3}{4} \times \frac{3}{4}$	19 × 19	014-0166	
	SGN 6	Flare int. x ext. ¹⁾	$\frac{1}{4} \times \frac{1}{4}$	6 × 6	014-0171	
	SGN 10		$\frac{3}{8} \times \frac{3}{8}$	10 × 10	014-0172	
	SGN 12		$\frac{1}{2} \times \frac{1}{2}$	12 × 12	014-0173	
	SGN 16		$\frac{5}{8} \times \frac{5}{8}$	16 × 16	014-0174	
	SGN 19		$\frac{3}{4} \times \frac{3}{4}$	19 × 19	014-0175	
	SGN 6s	ODF × ODF solder	$\frac{1}{4} \times \frac{1}{4}$	—	014-0181	
	SGN 10s		$\frac{3}{8} \times \frac{3}{8}$	—	014-0182	
	SGN 12s		$\frac{1}{2} \times \frac{1}{2}$	—	014-0183	
	SGN 16s		$\frac{5}{8} \times \frac{5}{8}$	16 × 16	014-0184	
	SGN 19s		$\frac{3}{4} \times \frac{3}{4}$	19 × 19	014-0185	
	SGN 22s		$\frac{7}{8} \times \frac{7}{8}$	22 × 22	014-0186	
	SGN 22s		$1 \frac{1}{8} \times 1 \frac{1}{8}$	—	014-0187	
	SGN 6s	ODF × ODF solder	—	6 × 6	014-0191	
	SGN 10s		—	10 × 10	014-0192	
	SGN 12s		—	12 × 12	014-0193	
	SGN 18s		—	18 × 18	014-0195	
		SGN 6s	ODF × ODM solder	$\frac{1}{4} \times \frac{1}{4}$	—	014-0201
		SGN 10s		$\frac{3}{8} \times \frac{3}{8}$	—	014-0202
		SGN 12s		$\frac{1}{2} \times \frac{1}{2}$	—	014-0203
SGN 16s		$\frac{5}{8} \times \frac{5}{8}$		16 × 16	014-0204	
SGN 22s		$\frac{7}{8} \times \frac{7}{8}$		22 × 22	014-0206	

¹⁾ Can be screwed directly into the filter drier.

Ordering
(continued)

Socket type

	Type	Version	Connection		Code no.
			1	2	
 <p>← 1</p>	SGR $\frac{3}{4}$	Pipe thread	G $\frac{3}{4}$ A ¹⁾	—	014-0004
	SGR $\frac{3}{4}$	NPT	$\frac{3}{4}$ - 14 NPT ²⁾	—	014-0005
	SGR $\frac{1}{2}$	NPT	$\frac{1}{2}$ - 14 NPT ²⁾	—	014-0002
 <p>← 1</p>	SGRI	SGRI	$\frac{1}{2}$ - 14 NPT ²⁾	—	014-0131
	SGRI	SGRI for saddle	M24 × 1	—	014-1154
 <p>← 1</p>	SGRN	SGRN	$\frac{1}{2}$ - 14 NPT ²⁾	—	014-0006
	SGRN	SGRN for saddle	M24 × 1	—	014-1155
 <p>← 1</p> <p>← 2</p>	SGS	Tube fitting	M24 × 1	$\frac{7}{8}$	014-1059
	SGS	Tube fitting	M24 × 1	1 $\frac{1}{8}$	014-1056
	SGS	Tube fitting	M24 × 1	1 $\frac{3}{8}$	014-1057
	SGS	Tube fitting	M24 × 1	1 $\frac{5}{8}$	014-1058
	SGS	Tube fitting	M24 × 1	2 $\frac{1}{8}$	014-1067
	SGS	Tube fitting	M24 × 1	3 $\frac{1}{8}$	014-1068
 <p>← 1</p>	SGRN	SGRN for saddle	M20 × 1.5	—	014-1603
 <p>← 1</p> <p>← 1</p> <p>← 2</p>	Sight glass saddle	Tube fitting	M20 × 1.5	3 $\frac{1}{8}$	014-1072

¹⁾ ISO 228/1

²⁾ ANSI/ASME B1.20.1

Dimensions [mm]
and weights [kg]

SGI / SGN flare, int. x ext.

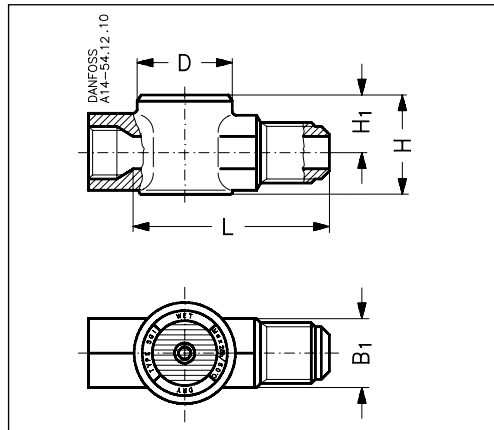

SGI / SGN flare, ext. x ext.

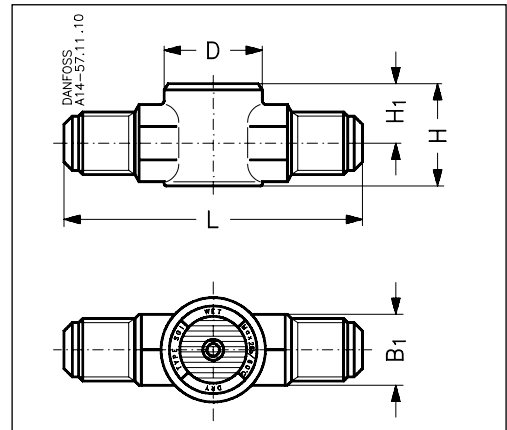

Type	Version	L	H	H ₁	B ₁	øD	Net weight
SGI / SGN 6	Flare ext. x ext.	67	24	14	14	27	0.1
SGI / SGN 10		82	28	16	19	32	0.2
SGI / SGN 12		88	30	18	22	32	0.3
SGI / SGN 16		104	37	21	27	37	0.4
SGI / SGN 19		110	41	22	32	37	0.5
SGI / SGN 6	Flare int. x ext.	46	24	14	16	27	0.1
SGI / SGN 10		57	30	18	22	32	0.2
SGI / SGN 12		59	30	18	24	32	0.3
SGI / SGN 16		71	37	21	27	37	0.4
SGI / SGN 19		75	41	22	32	37	0.5

SGR

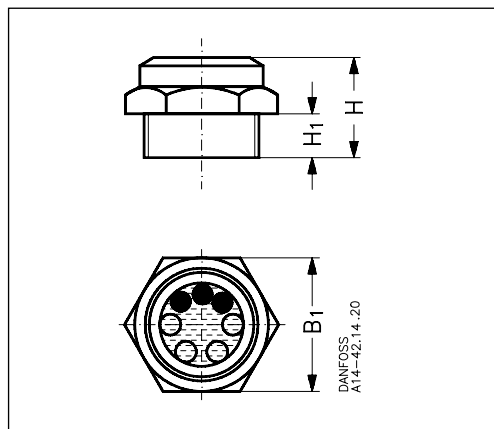

SCRI / SGRN

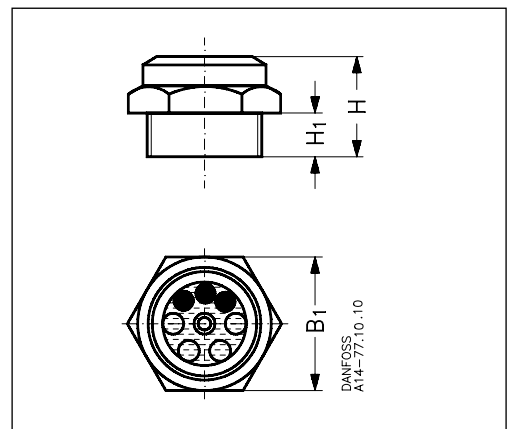

Type	Version	H	H ₁	B ₁	Net weight
SGR 1/2	NPT	30	18	27	0.1
SGR 3/4	Pipe thread	23	10	32	0.1
SGR 3/4	NPT	31	18	32	0.1
SGRN 1/2	NPT	30	18	27	0.1

**Dimensions [mm]
and weights [kg]**
(continued)

SGI / SGN solder ODF × ODF

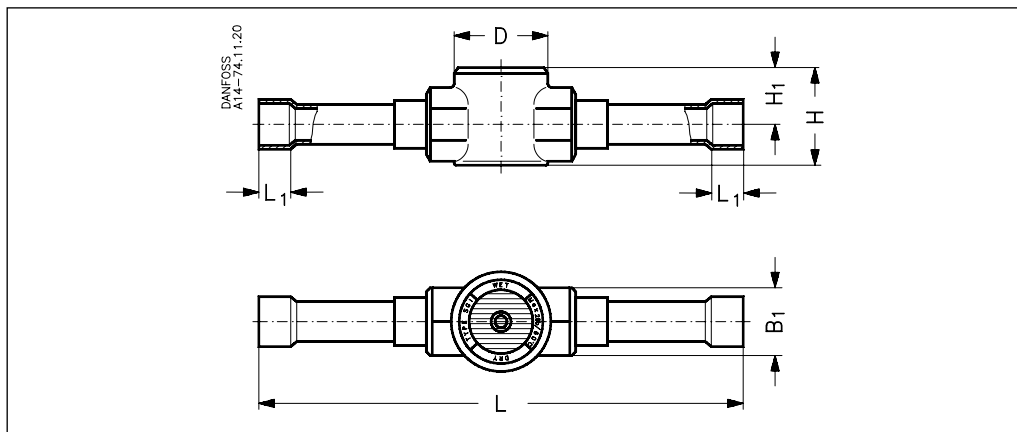

SGI / SGN solder ODF × ODM

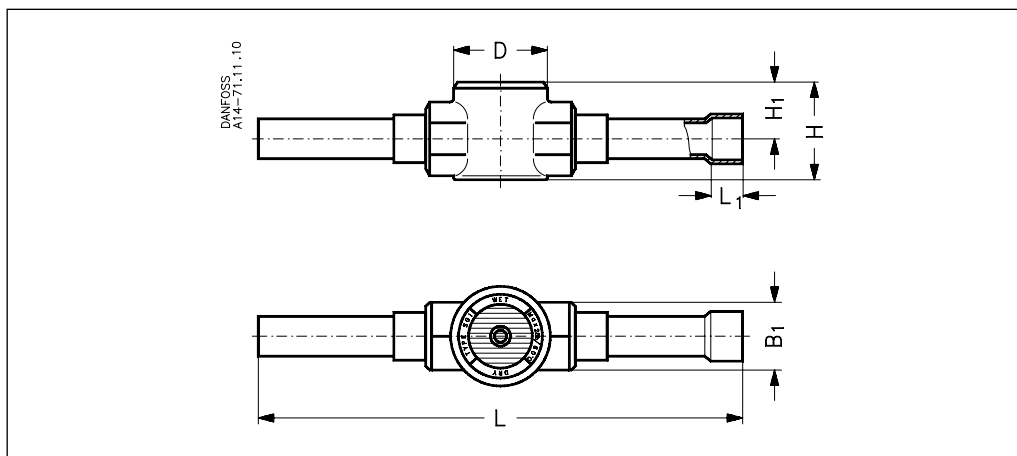

Type	Version	L	L ₁	H	H ₁	B ₁	øD	Net weight
SGI / SGN 6s	ODF × ODF solder	101	7	24	14	14	27	0.1
SGI / SGN 10s		119	9	24	14	14	27	0.1
SGI / SGN 12s		146	10	28	16	19	27	0.2
SGI / SGN 16s		146	12	30	18	22	27	0.2
SGI / SGN 18s		173	14	37	21	27	37	0.3
SGI / SGN 22s		173	17	37	21	27	27	0.3
SGI / SGN 22s		173	22	37	21	27	27	0.3
SGI / SGN 6s	ODF × ODM solder	101	7	24	14	14	27	0.1
SGI / SGN 10s		119	9	24	14	14	27	0.1
SGI / SGN 12s		146	10	28	16	19	27	0.2
SGI / SGN 16s		146	12	30	18	22	27	0.2

Danfoss can accept no responsibility for possible errors in catalogues, brochures and other printed material. Danfoss reserves the right to alter its products without notice. This also applies to products already on order provided that such alterations can be made without consequential changes being necessary in specifications already agreed. All trademarks in this material are property of the respective companies. Danfoss and the Danfoss logotype are trademarks of Danfoss A/S. All rights reserved.