

Data sheet

# Condensing pressure regulator, type KVR Differential pressure valve, type NRD



The condensing pressure regulator, type KVR can be mounted in either the gas or liquid side of the condenser in refrigeration and air conditioning systems. They are used to maintain a constant and sufficiently high condensing pressure with systems using air-cooled condensers.

They can also be used with valve types NRD or KVD to assure that adequate pressure is maintained on the receiver.

**Features**

- Accurate, adjustable pressure regulation
- Wide capacity and operating range
- Pulsation damping design
- Stainless steel bellows
- Compact angle design for easy installation in any position
- “Hermetic” brazed construction
- ¼ in. Schrader valve for pressure gauge connection
- Available with flare or ODF solder connections
- Can be used as a relief valve from high pressure to suction side
- KVR 12- 22: Compliant with ATEX hazard zone 2
- NRD: for use with HCFC, HFC and HC refrigerants

**Approvals**

UL LISTED, file SA7200  
GOST AN30

**Technical data**

<b>Refrigerants</b>	HCFC, HFC and HC: KVR 12-22
	HCFC and non-flammable HFC: KVR 28-35
<b>Regulation range</b>	Pe = 73.00 – 254.00 psig
	Factory setting = 145 psig
<b>Maximum working pressure</b>	KVR: PS/MWP = 406 psig
	NRD: PS/MWP = 667 psig
<b>Maximum test pressure</b>	KVR: Pe = 450 psig
	NRD: Pe = 870 psig
<b>Medium temperature range</b>	KVR: -49 – 266 °F
<b>P band (full valve stroke)</b>	KVR 12 – 22: 90 psi
	KVR 28 – 35: 72.5 psi
<b>Opening differential pressure for NRD</b>	Start opening: $\Delta p = 20$ psi
	Fully open: $\Delta p = 43$ psi

**Metric conversions**

1 psi = 0.07 bar  
 $\frac{5}{9} (t_1 \text{ } ^\circ\text{F} - 32) = t_2 \text{ } ^\circ\text{C}$

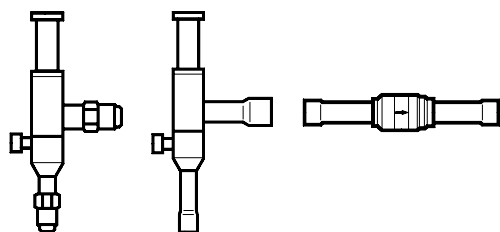
**Ordering**

KVR 12, KVR 15, KVR 22, KVR 28, KVR 35, NRD

Type	Rated liquid capacity <sup>1)</sup> (Evaporator capacity) [TR]				Rated hot gas <sup>1)</sup> (Evaporator capacity) [TR]				Flare connection <sup>2)</sup> [in.]	Code no.	Solder connection [in.]	Code no.
	R22	R134a	R404A/ R507	R407C	R22	R134a	R404A/ R507	R407C				
KVR 12	12.7	11.8	8.2	13.8	4.13	3.03	3.27	4.50	1/2	034L0091	1/2	034L0093
KVR 15	12.7	11.8	8.2	13.8	4.13	3.03	3.27	4.50	5/8	034L0092	5/8	034L0097
KVR 22	12.7	11.8	8.2	13.8	4.13	3.03	3.27	4.50	—	—	7/8	034L0094
KVR 28	32.6	30.2	20.9	35.5	10.93	8.04	8.66	11.91	—	—	1 1/8	034L0095
KVR 35	32.6	30.2	20.9	35.5	10.93	8.04	8.66	11.91	—	—	1 3/8	034L0100
NRD	—	—	—	—	—	—	—	—	—	—	1/2	020-1132

<sup>1)</sup> Rated capacity is based on:  
 – evaporating temperature  $t_e = 40$  °F  
 – condensing temperature  $t_c = 110$  °F  
 – pressure drop across the valve  
 $\Delta p = 3$  psi for liquid capacity  
 $\Delta p = 6$  psi for hot gas capacity

<sup>2)</sup> KVR are delivered without flare nuts.  
 Separate flare nuts can be supplied:  
 1/2 in. **code no. 011L1103**  
 5/8 in. **code no. 011L1167**

The connection dimensions chosen must not be too small, as gas velocities in excess of 130 ft/s at the inlet of the regulator can result in flow noise.

Liquid capacity

Max. regulator capacity  $Q_e$  <sup>1)</sup>

Type	Condensing temperature $t_c$	Liquid capacity [TR] (Evaporator capacity)				
		Offset 45 psi				
	[°F]	1.5	3	6	10	25
<b>R22</b>						
KVR 12 KVR 15 KVR 22	50	13.1	17.6	25.2	32.9	52.6
	70	11.9	16.0	23.0	30.0	48.0
	90	10.6	14.4	20.8	27.0	43.2
	110	9.2	12.7	18.4	23.9	38.2
	130	7.8	11.0	16.0	20.7	33.1
KVR 28 KVR 35	50	33.5	45.0	64.4	84.2	134.6
	70	30.4	41.1	58.9	76.8	122.8
	90	27.1	37.0	53.2	69.2	110.6
	110	23.6	32.6	47.2	61.3	97.8
	130	20.0	28.0	40.9	53.0	84.6
<b>R134a</b>						
KVR 12 KVR 15 KVR 22	50	12.0	16.9	24.0	31.0	49.1
	70	11.9	16.0	23.0	30.0	48.0
	90	9.6	13.6	19.2	24.8	39.3
	110	8.4	11.8	16.7	21.6	34.2
	130	7.1	10.0	14.2	18.3	29.0
KVR 28 KVR 35	50	30.7	43.4	61.3	79.2	126.0
	70	27.6	39.1	55.3	71.4	113.0
	90	24.5	34.7	49.1	63.4	100.0
	110	21.4	30.2	42.8	55.3	87.5
	130	18.1	25.6	36.3	46.9	74.2

Hot gas capacity [TR] (Evaporator capacity)				
Offset 45 psi				
Pressure drop $\Delta p$ [psi]				
1.5	3	6	10	25
<b>R22</b>				
1.81	2.47	3.52	4.51	6.86
1.92	2.62	3.75	4.83	7.44
2.04	2.76	3.96	5.12	7.94
2.13	2.89	4.13	5.36	8.34
2.20	2.98	4.27	5.54	8.64
4.77	6.50	9.31	11.95	18.15
5.11	6.93	9.92	12.79	19.66
5.42	7.34	10.48	13.54	20.98
5.67	7.65	10.93	14.16	22.06
5.79	7.83	11.23	14.60	22.85
<b>R134a</b>				
1.40	1.97	2.75	3.50	5.15
1.92	2.62	3.75	4.83	7.44
1.50	2.12	2.97	3.80	5.75
1.53	2.15	3.03	3.87	5.92
1.52	2.14	3.01	3.86	5.95
3.72	5.24	7.31	9.26	13.60
3.87	5.44	7.63	9.71	14.49
3.99	5.62	7.89	10.07	15.22
4.06	5.71	8.04	10.28	15.69
4.03	5.68	8.00	10.25	15.77

Metric conversions  
 1 psi = 0.07 bar  
 $\frac{5}{9}(t_1 \text{ °F} - 32) = t_2 \text{ °C}$   
 1 TR = 3.5 kW  
 1 in. = 25.4 mm

<sup>1)</sup>The capacities are based on:  
 Evaporating temperature  $t_e = 40 \text{ °F}$ .  
 For other evaporating temperatures see table below.

Correction factors (evaporating temperature)

$t_e$ [°F]	-40	-20	0	20	40	50
R22	1.12	1.09	1.05	1.03	1.0	0.98
R134a	1.22	1.16	1.10	1.04	1.0	0.96

System capacity x correction factor = table capacity.

**Liquid capacity**  
(continued)

Maximum regulator capacity  $Q_e$  <sup>1)</sup>

Type	Condensing temperature $t_c$	Liquid capacity [TR] (Evaporator capacity)					Hot gas capacity [TR] (Evaporator capacity)				
		Offset 45 psi					Offset 45 psi				
	[°F]	Pressure drop $\Delta p$ [psi]					Pressure drop $\Delta p$ [psi]				
		1.5	3	6	10	25	1.5	3	6	10	25
<b>R404A/R507</b>											
KVR 12 KVR 15 KVR 22	50	9.2	12.4	17.6	23.0	37.0	1.63	2.09	2.99	3.84	5.87
	70	8.1	10.9	15.7	20.4	32.7	1.60	2.17	3.10	4.00	6.17
	90	7.0	9.6	13.8	17.9	28.7	1.65	2.25	3.21	4.15	6.45
	110	5.9	8.2	11.8	15.4	24.5	1.68	2.28	3.27	4.24	6.60
	130	4.8	6.8	10.0	13.0	20.6	1.69	2.31	3.34	4.34	6.78
KVR 28 KVR 35	50	23.6	31.7	45.2	59.0	94.5	4.06	5.52	7.89	10.15	15.48
	70	20.8	27.9	40.1	52.2	83.6	4.24	5.74	8.20	10.58	16.32
	90	17.9	24.5	35.2	45.9	73.4	4.41	5.96	8.50	10.99	17.06
	110	15.1	20.9	30.3	39.3	62.7	4.88	6.06	8.66	11.22	17.49
	130	12.3	17.4	25.7	33.1	52.7	4.49	6.12	8.82	11.45	17.92
<b>R407C</b>											
KVR 12 KVR 15 KVR 22	50	4.2	19.0	27.2	35.5	56.8	1.96	2.67	3.80	4.87	7.41
	70	12.9	17.3	24.8	32.4	51.8	2.07	2.83	4.05	5.22	8.04
	90	11.5	15.6	22.5	29.2	46.7	2.20	2.98	4.28	5.53	8.58
	110	10.0	13.8	20.1	26.1	41.6	2.32	3.15	4.50	5.84	9.09
	130	8.6	12.1	17.6	22.8	36.4	2.42	3.28	4.70	6.09	9.50
KVR 28 KVR 35	50	36.2	48.6	69.6	90.9	145.4	5.15	7.02	10.06	12.91	19.60
	70	32.8	44.4	63.6	82.9	132.6	5.52	7.48	10.71	13.81	21.23
	90	29.3	40.0	57.5	74.7	119.5	5.85	7.93	11.32	16.62	22.66
	110	25.7	35.5	51.5	66.8	106.6	6.18	8.34	11.91	15.43	24.05
	130	22.0	30.8	45.0	58.3	93.1	6.37	8.61	12.35	16.06	25.14

Metric conversions  
 1 psi = 0.07 bar  
 $\frac{5}{9}(t_1 \text{ °F} - 32) = t_2 \text{ °C}$   
 1 TR = 3.5 kW  
 1 in. = 25.4 mm

<sup>1)</sup> The capacities are based on:  
 Evaporating temperature  $t_e = 40 \text{ °F}$ .  
 For other evaporating temperatures see table below.

Correction factors (evaporating temperature)

$t_e$ [°F]	-40	-20	0	20	40	50
R404A/R507	1.32	1.22	1.14	1.06	1.0	0.95
R407C	1.20	1.15	1.09	1.04	1.0	0.96

System capacity x correction factor = table capacity.

**Sizing**

For optimum performance, it is important to select a KVR valve according to system conditions and application.

The following data must be used when sizing a KVR valve:

- Refrigerant: HCFC, HFC and HC:KVR 12-22, HCFC and non-flammable HFC: KVR 28-35
- Evaporator capacity  $Q_e$  in [TR]
- Evaporating temperature  $t_e$  in [°F]
- Condensing temperature  $t_c$  in [°F]
- Connection type: flare or solder
- Connection size in [in.]

**Valve selection**

*Example*

When selecting the appropriate valve it may be necessary to convert the actual evaporator capacity using a correction factors. This is required when your system conditions are different than the table conditions. The selection is also dependant on the acceptable pressure drop across the valve. The following example illustrates how this is done.

*KVR in a liquid capacity application*

- Refrigerant: R22
- Evaporator capacity:  $Q_e = 28.7$  TR
- Evaporating temperature:  $t_e = -40$  °F ~ 21 psig
- Condensing temperature:  $t_c = 90$  °F ~ 170 psig
- Connection type: Solder
- Connection size:  $5/8$  in.

**Application example**

*Liquid capacity application*

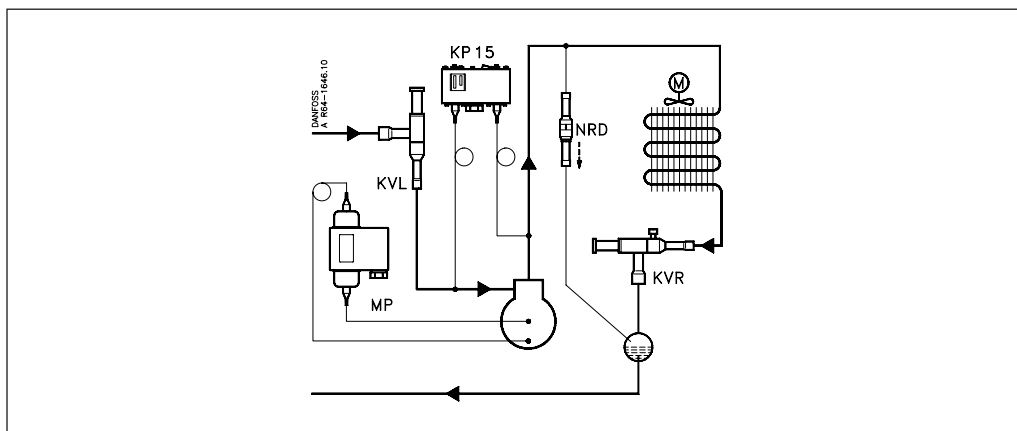

*Hot gas capacity application*

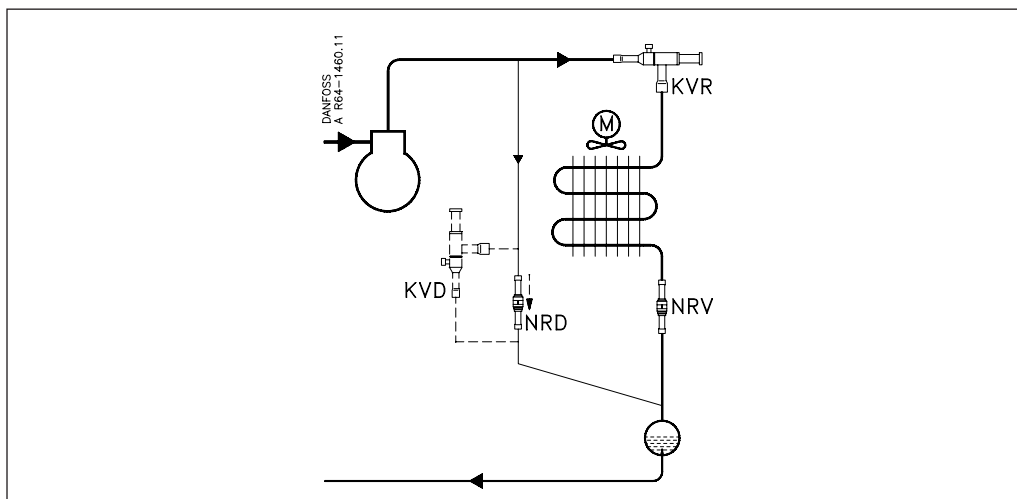

**Valve selection**  
(continued)

**Step 1**

Determine the correction factor for evaporating temperature  $t_e$ .

From the correction factors table an evaporating temperature of  $-40\text{ }^\circ\text{F}$ , R22 corresponds to a factor of 1.12.

*Correction factors (evaporating temperature)*

$t_e$ [ $^\circ\text{F}$ ]	-40	-30	-20	-10	0	10
R22	1.12	1.09	1.05	1.03	1.0	0.98
R134a	1.22	1.16	1.10	1.04	1.0	0.96
R404A/R507	1.32	1.22	1.14	1.06	1.0	0.95
R407C	1.20	1.15	1.09	1.04	1.0	0.96

**Step 2**

Corrected evaporator capacity is  
 $Q_e = 28.7 \times 1.12 = 32.14\text{ TR}$

**Step 3**

Now select the appropriate capacity table and choose the line for a condensing temperature  $t_c = 90\text{ }^\circ\text{F}$ .  
 Using the corrected evaporator capacity, select a valve that provides an equivalent or greater capacity at an acceptable pressure drop.

KVR 12, KVR 15, KVR 22 delivers 38.2 TR at a 25 psi pressure drop across the valve. Based on the required connection size of  $\frac{5}{8}$  in. ODF, the KVR 15 is the proper selection for this example.

**Step 4**

KVR 15,  $\frac{5}{8}$  in. solder connection:  
**code no. 034L0097.**

Design / Function

KVR

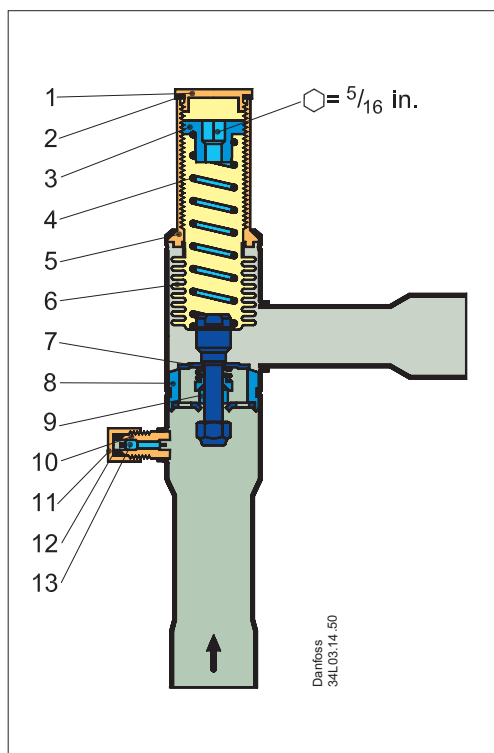

KVR

1. Seal cap
2. Gasket
3. Setting screw
4. Main spring
5. Valve body
6. Equalizing bellows
7. Valve plate
8. Valve seat
9. Damping device
10. Manometer connection
11. Cap
12. Gasket
13. Insert

NRD

1. Piston
2. Valve plate
3. Piston guide
4. Valve body
5. Spring

NRD

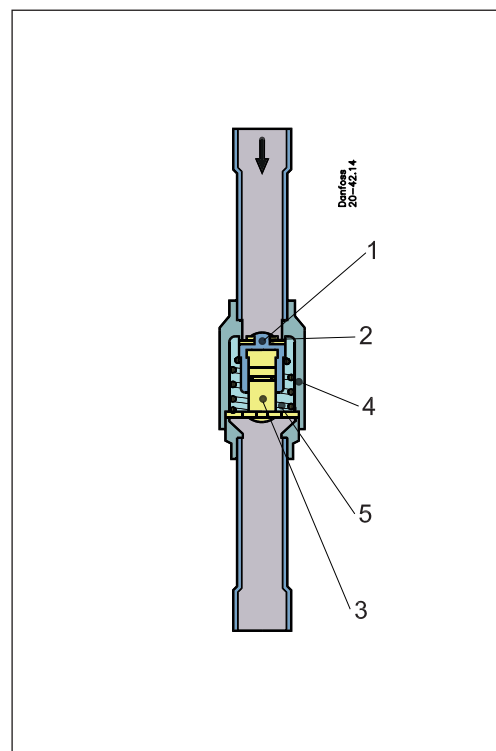

The condensing pressure regulator, type KVR opens upon a rise in pressure on the inlet side, i.e. when the pressure in the condenser reaches the set value. KVR regulates on the inlet pressure only. Pressure variations on the outlet side of the regulator do not affect the degree of opening, as the valve is equipped with equalization bellows (6). The bellows has an effective area corresponding to that of the valve seat neutralizing any changes to the setting.

The valve is also equipped with a damping device (9) providing protection against pulsations which can normally arise in a refrigeration system. The damping device helps to ensure long life for the regulator without impairing regulation accuracy. Differential valve type NRD begins to open when the pressure drop in the valve is 20 psig, and is fully open when the pressure drop is 43 psig.

P-band and Offset

Principle diagram

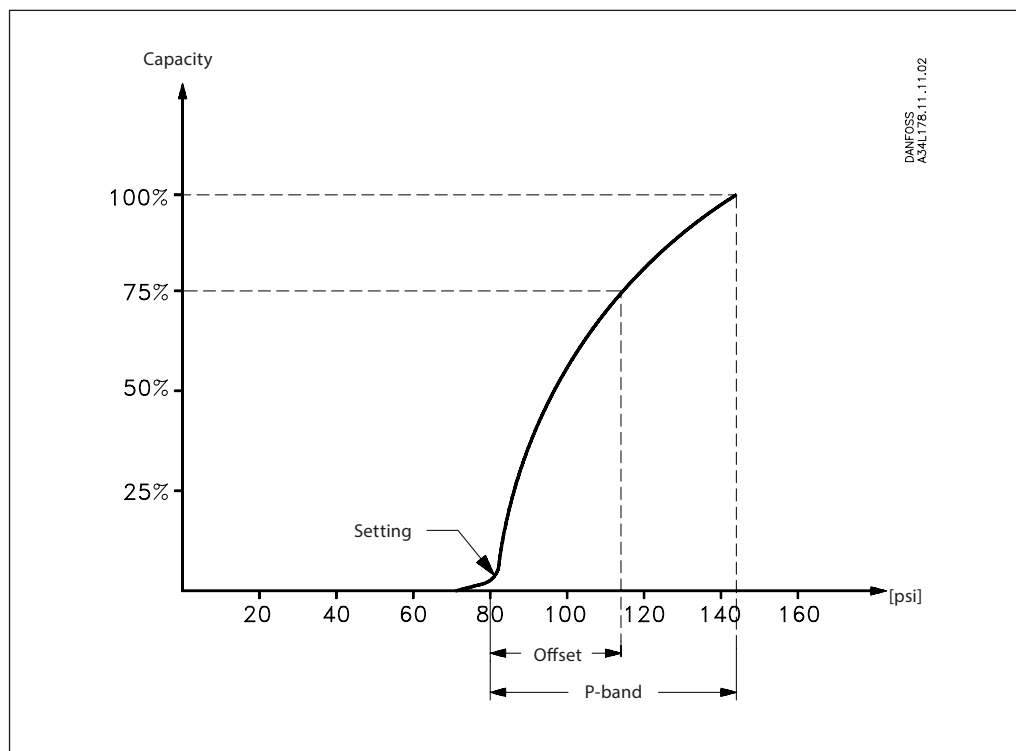

Metric conversions  
 1 psi = 0.07 bar  
 $\frac{5}{9}(t_1 \text{ } ^\circ\text{F} - 32) = t_2 \text{ } ^\circ\text{C}$

*Proportional band*

The proportional band or P-band is defined as the amount of pressure required to move the valve plate from closed to full open position.

*Example:*

If the valve is set to open at 120 psig and the valve P-band is 90 psi, the valve will give maximum capacity when the inlet pressure reaches 210 psig.

*Offset*

The offset is defined as the permissible pressure variation in condenser pressure (temperature). It is calculated as the difference between the required working pressure and the minimum allowable pressure. The offset is always a part of the P-band.

*Example with R22:*

A working temperature of 110 °F ~ 230 psig is required, and the temperature must not drop below 100 °C ~ 200 psig (set point). The offset will then be 30 psi.



Dimensions [mm]  
and weights [kg]

KVR

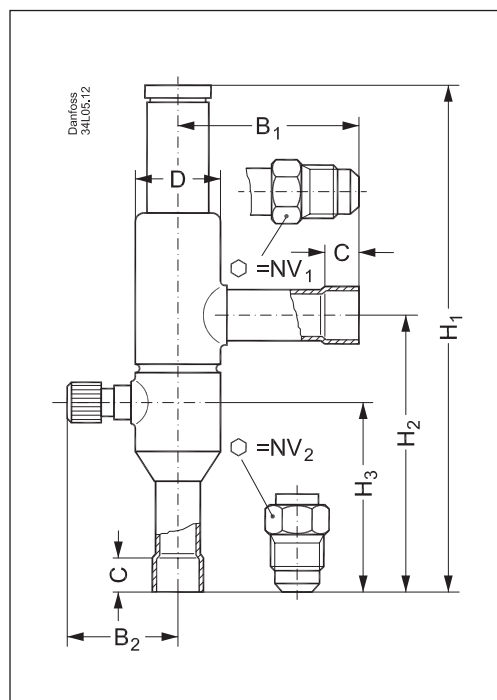

NRD

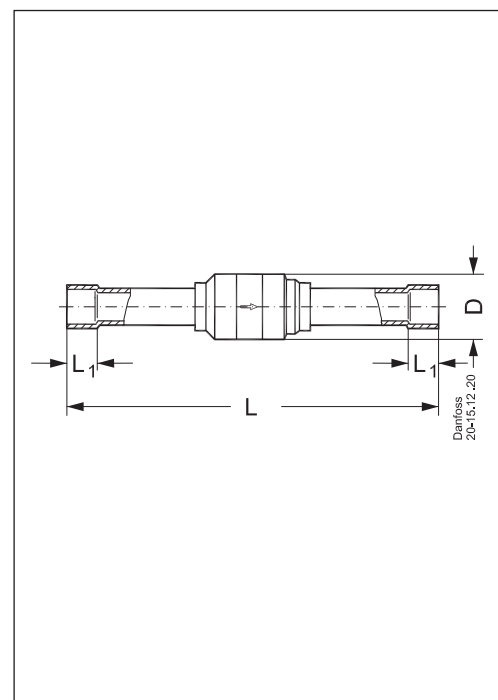

KVR, NRD

Type	Connection		NV <sub>1</sub>	NV <sub>2</sub>	H <sub>1</sub>	H <sub>2</sub>	H <sub>3</sub>	L	L <sub>1</sub>	B <sub>1</sub>	B <sub>2</sub>	C Solder	øD	Net weight
	Flare	Solder ODF												
KVR 12	1/2	1/2	0.748	0.748	7.045	3.898	2.598	—	—	2.520	1.614	0.394	1.181	0.88
KVR 15	5/8	5/8	0.945	0.945	7.045	3.898	2.598	—	—	2.520	1.614	0.472	1.181	0.88
KVR 22	—	7/8	—	—	7.045	3.898	2.598	—	—	2.520	1.614	0.669	1.181	0.88
KVR 28	—	1 1/8	—	—	10.197	5.945	4.055	—	—	4.134	1.890	0.787	1.693	2.20
KVR 35	—	1 3/8	—	—	10.197	5.945	4.055	—	—	4.134	1.890	0.984	1.693	2.20
NRD	—	1/2	—	—	—	—	—	5.157	0.394	—	—	—	0.866	0.22

Metric conversions  
1 in. = 25.4 mm  
1 lb = 0.454 kg

Danfoss can accept no responsibility for possible errors in catalogues, brochures and other printed material. Danfoss reserves the right to alter its products without notice. This also applies to products already on order provided that such alterations can be made without substantial changes being necessary in specifications already agreed. All trademarks in this material are property of the respective companies. Danfoss and the Danfoss logotype are trademarks of Danfoss A/S. All rights reserved.