

Installation guide

ELIMINATOR® Hermetic burn-out filter drier

Type DAS

023R95Z7

023R95Z7

Refrigerants R134a, R404A, R407C, R507, R22, R410A and other refrigerants (HCFC, HFC, HFO, HC)	Temperature range  -40 – 70 °C -40 – 160 °F	Max. working pressure PS / MWP = 35 bar / 500 psig
--	---	--

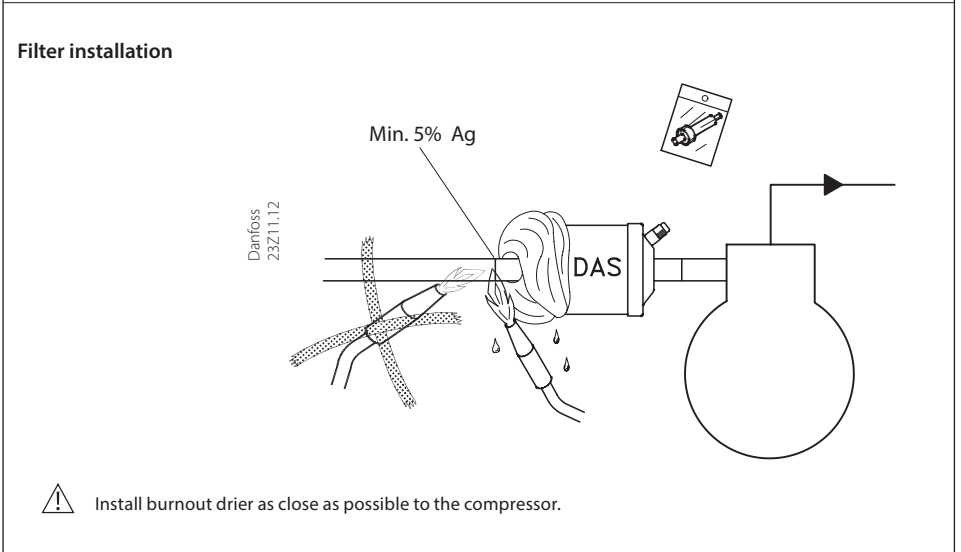
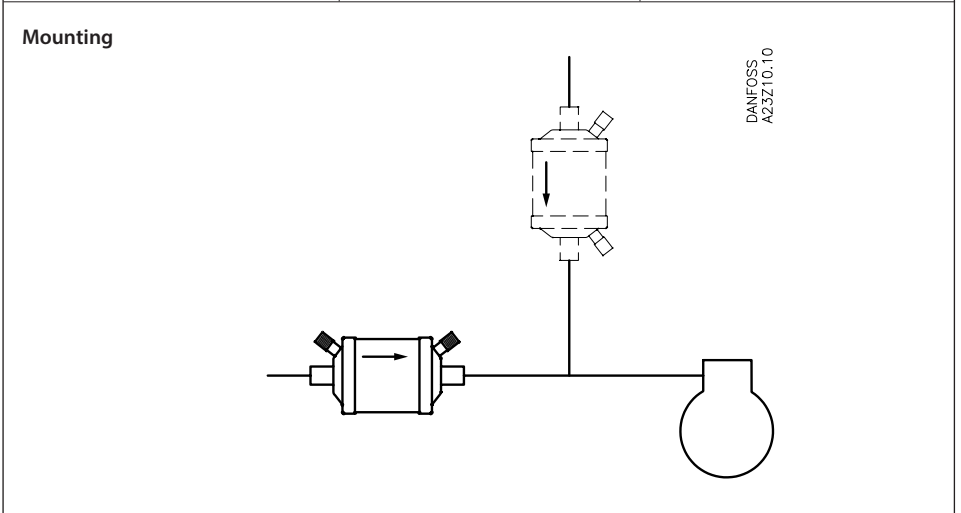

 Install burnout drier as close as possible to the compressor.

Schrader valve Installation

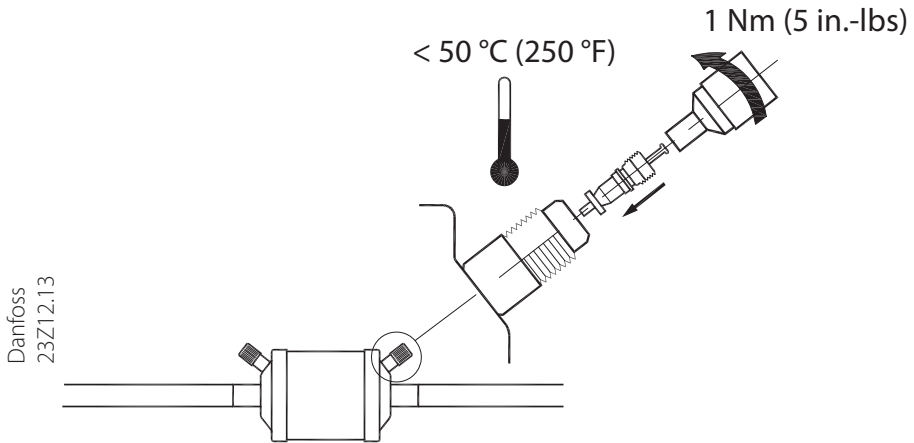

Initial pressure drop:

Record initial pressure drop and check again after 72 hours of operation. Replace drier if the pressure drop ([bar] / [psi]) across the core exceeds the following values.

Refrigerant	Evaporator temperature									
	-40 °C / -40 °F		-28.9 °C / -20 °F		-17.8 °C / 0 °F		-6.7 °C / 20 °F		4.4 °C / 40 °F	
	[bar]	[psi]	[bar]	[psi]	[bar]	[psi]	[bar]	[psi]	[bar]	[psi]
R404A, R407C, R507, R22	0.04	0.50	0.07	1.00	0.10	1.50	0.15	2.00	0.20	3.00
R134a	-	-	0.04	0.50	0.07	1.00	0.10	1.50	0.15	2.00
R410A	0.07	1.00	0.10	1.50	0.15	2.00	0.20	3.00	0.07	1.00