

Installation Guide

Check valve

NRVS 15-25

020R9508

020R9508

1

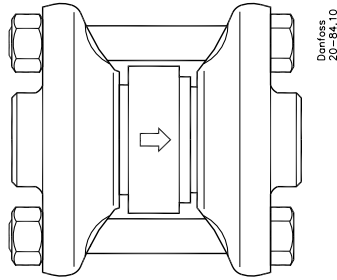

2

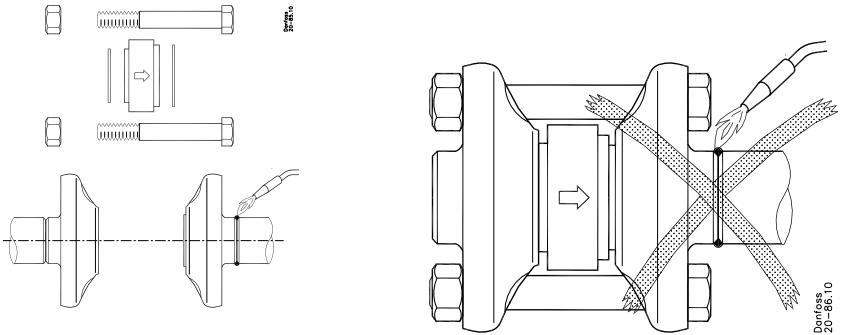

3

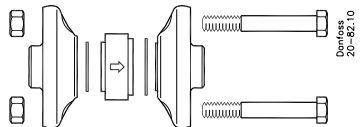

Type	Bolt	Max tightening torque	
		Nm	LB-feet
NRVS 15	2 x M12	50	37
NRVS 25	2x M 12	70	52

ENGLISH

Installation

Refrigerants

Applicable to HCFC, HFC and R717 (Ammonia).
Flammable hydrocarbons are not recommended.
The valve is only recommended for use in closed circuits. For further information please contact Danfoss.

Installation

The valve must be installed in the flow direction as indicated by the arrow on the valve housing (fig. 1). The valve is designed to withstand a high internal pressure. However, the piping system should be designed to avoid liquid traps and reduce the risk of hydraulic pressure caused by thermal expansion. It must be ensured that the valve is protected from pressure transients like "liquid hammer" in the system.

Welding

The internal parts should be removed before welding (fig. 2) to prevent damage to the gaskets, as well as the teflon gasket in the valve seat. Only materials and welding methods, compatible with the flange material, must be welded to the flanges. The flanges should be cleaned internally to remove welding debris on completion of welding and before the valve is reassembled.

Be careful not to damage the teflon on the cone.

The valve inclusive flanges must be free from stresses (external loads) after installation.

The valves must not be mounted in systems where the outlet side of the valve is open to atmosphere. Both the inlet and outlet side of the valve must always be connected to the system or properly capped off, for example with a welded-on end plate.

Assembly

Remove welding debris and any dirt from pipes and valve body before assembly.

Tightening

Tighten the staybolts and nut with a torque wrench, to the values indicated in the table (fig. 3).

Surface protection

The external surface of the flanges must be prevented against corrosion with a suitable protective coating after installation and assembly.

Maintenance

Dismantling the valve

Do not remove the valve housing while the valve is still under pressure.

- Check that the gasket has not been damaged.

Assembly

Remove any dirt from the body before the valve is assembled.

Tightening

Tighten the staybolts and nut with a torque wrench, to the values indicated in the table (fig. 3).

Use only original Danfoss parts, including gaskets for replacement. Materials of new parts are certified for the relevant refrigerant.

In cases of doubt, please contact Danfoss. Danfoss accepts no responsibility for errors and omissions. Danfoss Industrial Refrigeration reserves the right to make changes to products and specifications without prior notice.