

Installation Guide

Liquid level regulating valve PMFH 80-500

027R9522

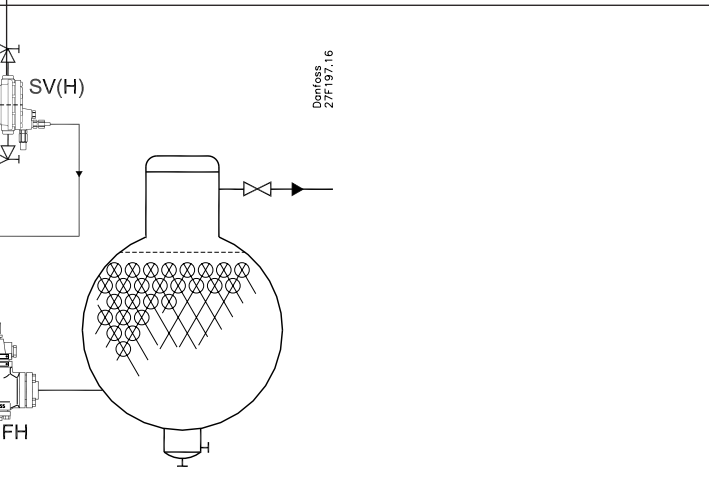

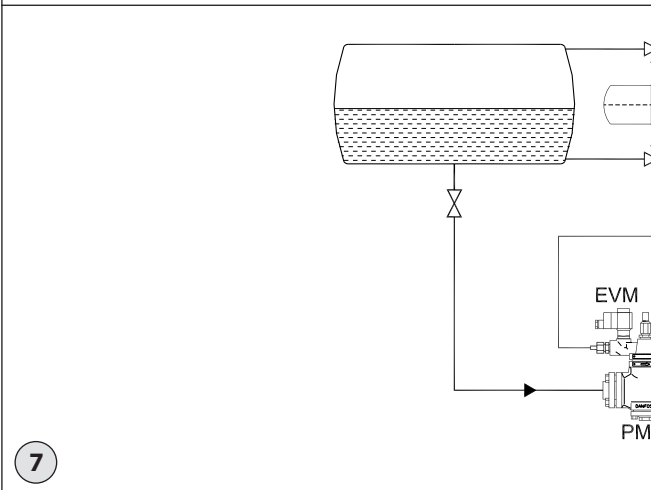
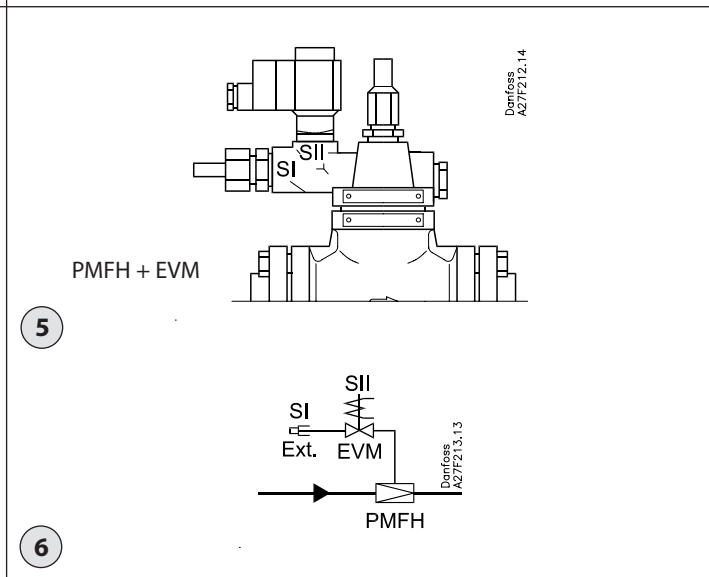
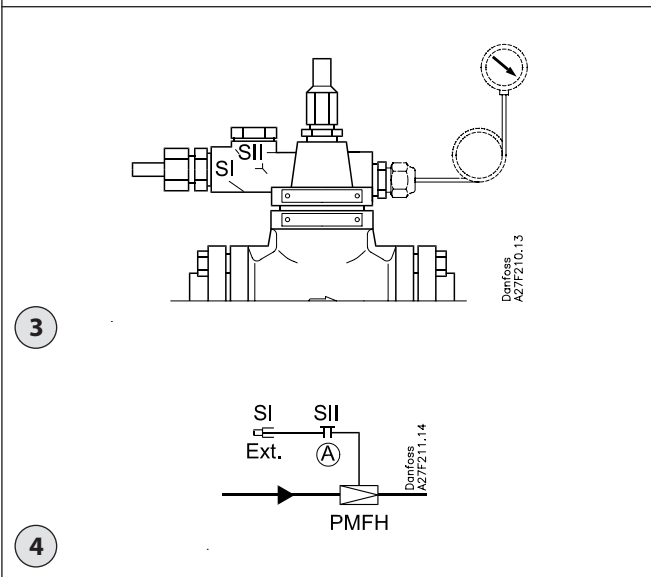
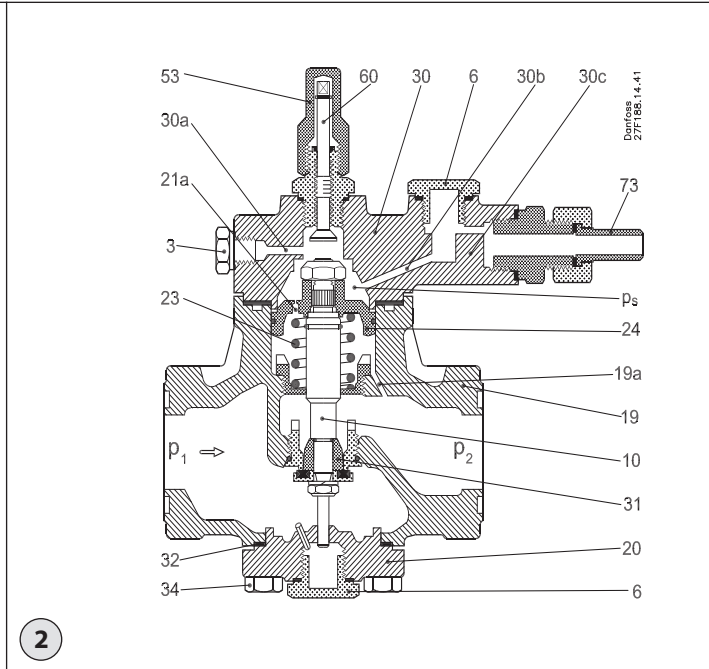
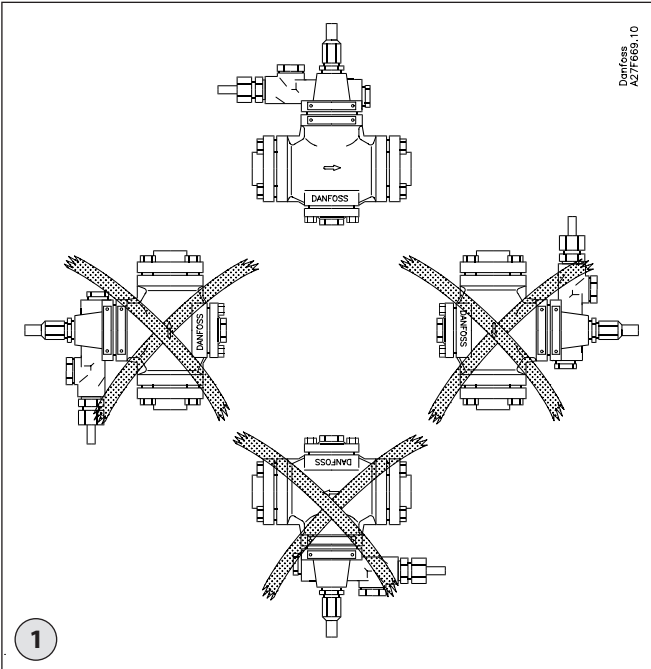
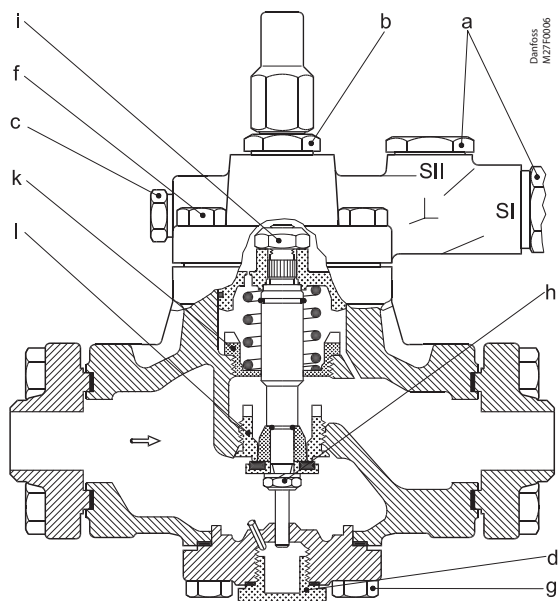

8

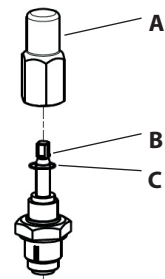

9

Pos. Item.	Tilspændingsmoment i Nm (10 Nm = 1 kpm) Tightening torque in Nm (1 Nm = 0.74 lb force ft) Anzugsmoment in Nm (10 Nm = 1 kpm) Couple de serrage en Nm (10 Nm = 1 kgf.m)				
	PMFH Størrelse Size Größe Dimension				
	80	125	200	300	500
a	50				
b	50				
c	30				
d	50				
f	40		60		80
g	40		60		80
h	17	34		49	
i	30				
k	80		100		120
l	50	60	100		120

Table 1

ENGLISH

Installation

Refrigerants

Applicable to HCFC, HFC and R717 (Ammonia).

Flammable hydrocarbons are not recommended. The valve is only recommended for use in closed circuits. For further information please contact Danfoss.

Temperature range

PMFH: $-60/+120^{\circ}\text{C}$ ($-76/+248^{\circ}\text{F}$)

Pressure range

PMFH: The valves are designed for a max. working pressure of 28 bar g (406 psi g).

Technical data

PMFH can be used in suction, liquid, hot-gas and liquid/vapour lines.

The PMFH regulates the flow of the medium by two step on/off function, depending on the control impulse from the screwed-on pilot valves.

Design

See fig. 2

- | | |
|--------------|----------------------------|
| 1. | Valve body |
| 1. a. | Channel in valve body 1 |
| 10. | Valve spindle |
| 12. | Valve plate |
| 23. | Spring |
| 24. | Servo piston |
| 24. a. | Channel in servo piston 24 |
| 30. | Bottom cover |
| 36. | Drain plug |
| 40. | Cover |
| 40. a. b. c. | Channels in cover 40 |
| 44. | Pressure gauge connection |
| 60. | Manual operating spindle |
| 73. | Pilot connection |
| 100. | Blanking plug |

Installation

Flange set for the PMFH is delivered separately. The valve must be installed with the arrow in the direction of the flow and the top cover upwards (fig. 1). The top cover can be rotated $4 \times 90^{\circ}$ in relation to the valve body.

The valve is fitted with a spindle for manual opening.

When an external pilot valve is used, the pilot line must be connected to the upper side of the main line so that any dirt and oil from the plant will not find its way into the pilot line.

The PMFH valve can be controlled by the SV float valve as shown on fig. 7. Please refer to SV instruction guidelines.

The valve is designed to withstand a high internal pressure. However, the piping system should be designed to avoid liquid traps and reduce the risk of hydraulic

pressure caused by thermal expansion. It must be ensured that the valve is protected from pressure transients like "liquid hammer" in the system.

Mounting of valve flanges

When welding/soldering the flanges to the system piping use only materials and welding/soldering methods compatible with the flange material.

- Make sure that piping into which a valve/flange is installed is properly supported and aligned square and plumb to the joining sections.
- Ensure that the finalized valve assembly is free of any stresses from external loads.
- Make certain that the heat affected zones (inside and outside) and the mating surfaces of gasketed joints are free of debris and rust and are in good condition.
- Use only new gaskets manufactured by Danfoss.
- Make sure that the bolts are adequately tightened in an alternating pattern.
- Use only original Danfoss stainless steel bolts provided with the valve. Stainless steel bolts offer corrosion protection and they ensure safe operation across the design operating range of the valve when installed properly.

Note: Stainless steel bolts have a slightly lower yield strength compared to carbon steel bolts. Be careful not to over-tighten the bolts.

- Ensure that flanges / valves are properly pressure tested, leak tested, evacuated before charging with refrigerant in accordance with ANSI / IIR 5, EN378-2 or ISO 5149-2.

PMFH valves must not be mounted in systems where the outlet side of the valve is open to atmosphere. The outlet side of the valve must always be connected to the system or properly capped off, for example with a welded-on end plate.

Colours and identification

The PMFH valves are Zinc-Chromated in the factory. If further corrosion protection is required, the valves can be painted. Precise identification of the valve is made via the ID plate on the top cover. The external surface of the valve housing must be prevented against corrosion with a suitable protective coating after installation and assembly.

Protection of the ID plate when repainting the valve is recommended.

Maintenance

Service

The PMFH valves are easy to dismantle and most of its parts are replaceable. When the bottom cover is removed, the strainer can be taken out for cleaning.

Do not open the valve while the valve is still under pressure.

- Check that the O-ring or gaskets have not been damaged.
- Check that the spindle is free of scratches and impact marks.
- If the teflon ring has been damaged, the parts must be replaced.

Assembly

Remove any dirt from the body before the valve is assembled. Check that all channels in the valve are not blocked with particles or similar.

Tightening

Tightening torques

See fig. 8 and table 1.

Note:

Always pay attention to the spindle during operation of the manual opener (see fig 9)

1. Make sure that the C-clip (C) is positioned on the spindle (B) and is intact. A new C-clip is available in the inspection kit for the valve.
2. Pay attention to the C-clip reaching the top nut of the packing gland when turning the manual stem clockwise for opening the valve. **Never use excessive torque and stop turning when the C-clip gets in contact with the top nut.**
3. When turning the spindle (B) anticlockwise, for deactivation of the manual opener, to the top point, tighten the spindle further anticlockwise to 8 Nm (5.9 lb/ft) torque.
4. Remount the cap (A) and tighten it clockwise to 8 Nm (5.9 lb/ft) torque.

Use only original Danfoss parts, including packing glands, O-rings and gaskets for replacement. Materials of new parts are certified for the relevant refrigerant.

In cases of doubt, please contact Danfoss.

Danfoss accepts no responsibility for errors and omissions. Danfoss Industrial Refrigeration reserves the right to make changes to products and specifications without prior notice.



The following text is applicable to the UL listed products PMFH 80-500

Applicable to all common non-flammable refrigerants, including/excluding (+) R717 and to non-corrosive gases/liquids dependent on sealing material compatibility (++). The design pressure shall not be less than the value outlined in Sec. 9.2 of ANSI/ASHRAE 15 for the refrigerant used in the system. (+++).

