

**Contents**

	<b>Page</b>
Installation .....	15
EVRA 32 & 40 precautions .....	15
When pressure testing .....	16
The coil .....	17
The correct product .....	18



**Installation**

All EVR/EVRA, and EVH types solenoid valves operate only when installed correctly in the direction of flow, i.e. in the direction indicated by the arrow.

Normally, solenoid valves installed ahead of a thermostatic expansion valve must be close to that valve.

This avoids liquid hammer when the solenoid valve opens.

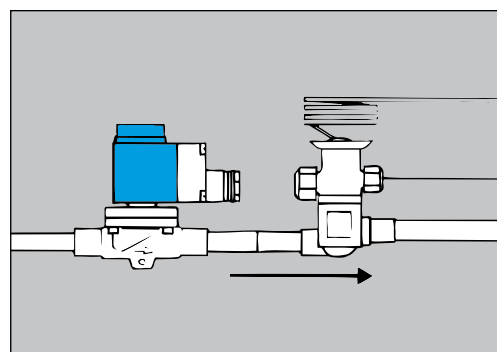

Af0\_0001

Solenoid valves

Ensure that pipes around the valve are properly installed so that no fracture can occur.

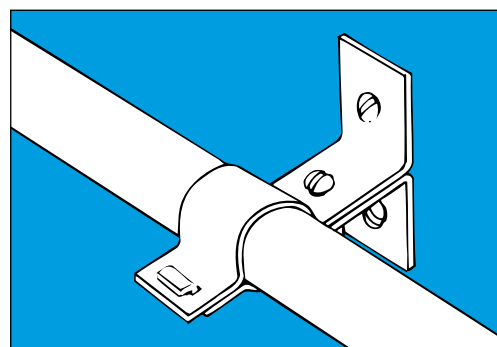

Af0\_0003

Brazing/welding EVR/EVRA and EVH solenoid valves does not normally necessitate dismantling, provided steps are taken to avoid heating the valve.

**Note!** Always protect the armature tube against weld spatter.

After tacking the valve to the pipe, remove the valve body to protect O-rings and gaskets against heat. In installations with welded steel pipe, a FA type strainer or similar mounted ahead of the solenoid valve is recommended. (On new plant, flushing out before starting up is recommended).

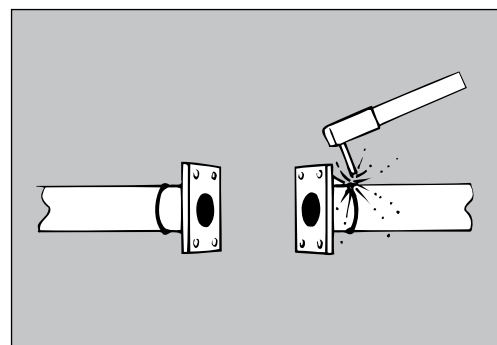

Af0\_0004

*EVRA 32 & 40 precautions*

*When pressure testing*

All solenoid valves in the system must be open, either by applying voltage to the coils or by opening the valves manually (provided a manual operation spindle is fitted).

Remember to screw the spindle back before starting up, otherwise the valve will be unable to close.

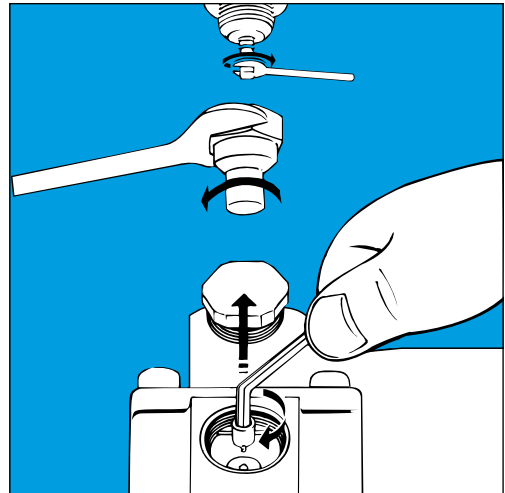

Afo\_0005

**Always use counter force when finally tightening the solenoid valve on pipes, i.e. two spanners on the same side of the valve.**

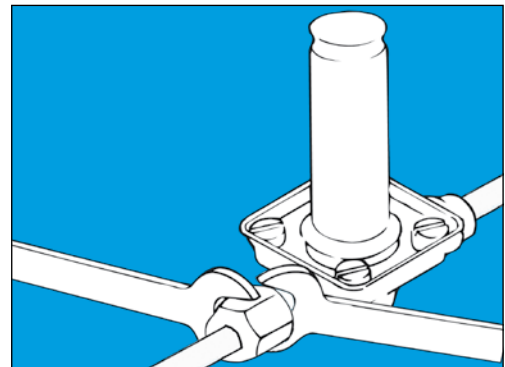

Afo\_0006

**The coil**

When fitting the coil, it has merely to be pressed down over the armature tube until a click is heard. This means that the coil has been correctly fitted.

**Note:** Remember to fit an O-ring between valve body and coil.

Be sure that the O-ring is smooth, not damaged and that the surface is free from paint or any other material.

**Note:** The O-ring must be changed at service.

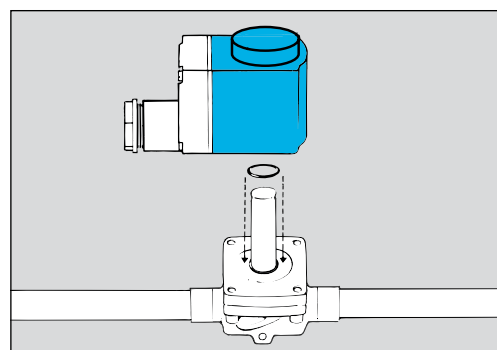

Af0\_0018

The coil can be removed by inserting a screwdriver between valve body and coil. The screwdriver can then be used as a lever to loosen the coil.

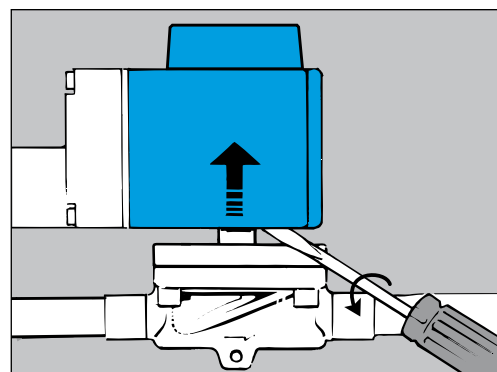

Af0\_0019

Be careful with cable entries. It must not be possible for water to enter the terminal box. The cable must be led out via a drip loop.

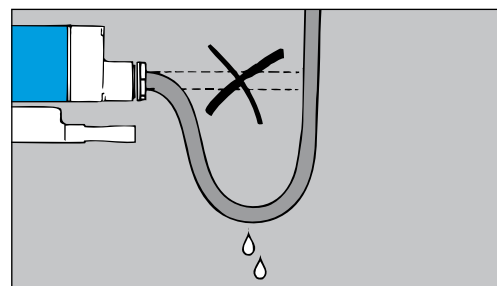

Af0\_0009

The entire cable circumference must be retained by the cable entry. Therefore, always use round cable (which is the only type of cable that can be sealed effectively).

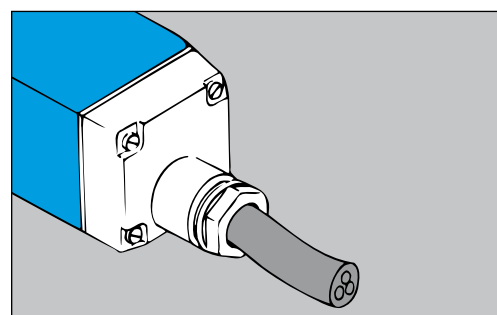

Af0\_0010

Be aware of the colour of leads in the cable. Yellow/green is always earth. Leads of one colour are either phase or neutral.

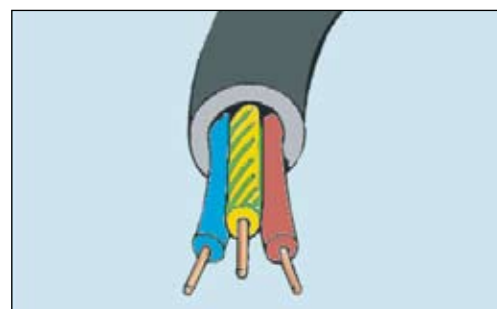

Af0\_0011

**Fitters notes**
**Solenoid valves**
*The coil (cont.)*

When removing a coil it might be necessary to use hand tools, e.g. two screwdrivers.

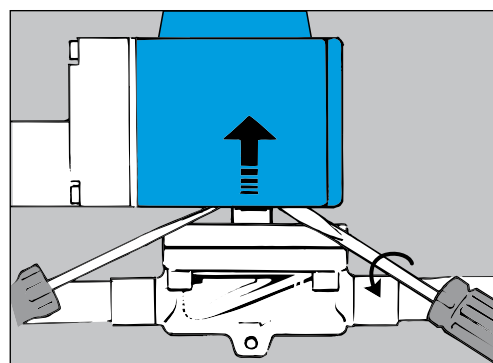

Af0\_0012

**The correct product**
*(The "old" coil type)*

Make sure that coil data (voltage and frequency) and supply voltage correspond. If they do not, the coil might burn out. Always ensure that valve and coil match each other.

When replacing a coil in an EVR 20 NC (NC = normally closed) note:

- A valve body using an a.c. coil has a square armature.
- A valve body using a d.c. coil has a round armature.

Fitting the wrong coil results in a lower MOPD. See data on the top nut. As far as possible, always choose single-frequency coils. These give off less heat than double-frequency coils. Use NC (normally closed) solenoid valves for systems in which the valve must remain closed (de-energised) for most of the operating time. Use NO (normally open) solenoid valves for systems in which the valve must remain open (de-energised) for most of the operating time. Never replace an NO (normally open) solenoid valve with an NC (normally closed) valve - or vice versa.

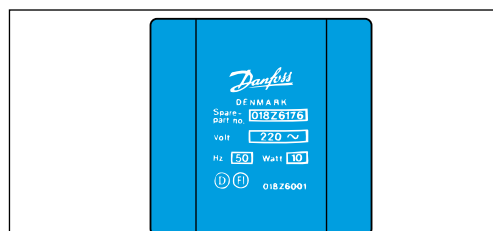

Af0\_0013

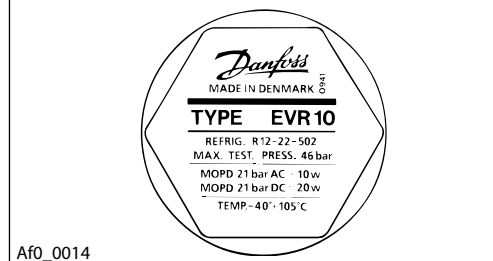

Af0\_0014

*(The new "clip-on" coil type)*

Two labels are supplied with each clip-on coil (see illustration).

The adhesive label is for attaching to the side of the coil, while the other, perforated label should be placed over the armature tube before the coil is clicked into position.

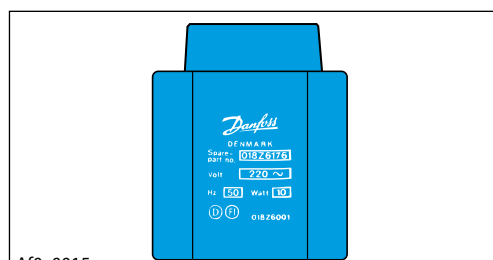

Af0\_0015

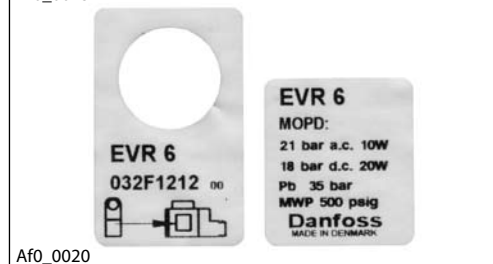

Af0\_0020