

# Instructions

Electronic Unit Type 105N4220,  
160-254V, AC 50-60Hz for BD150F Compressor

Fig. 1

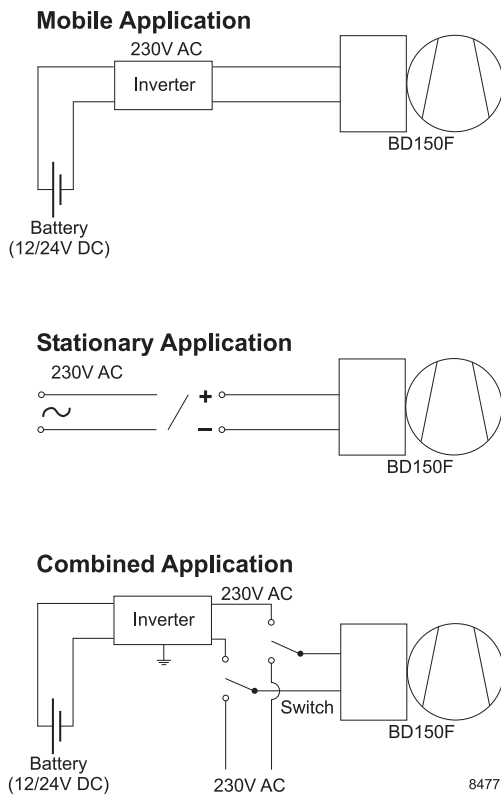
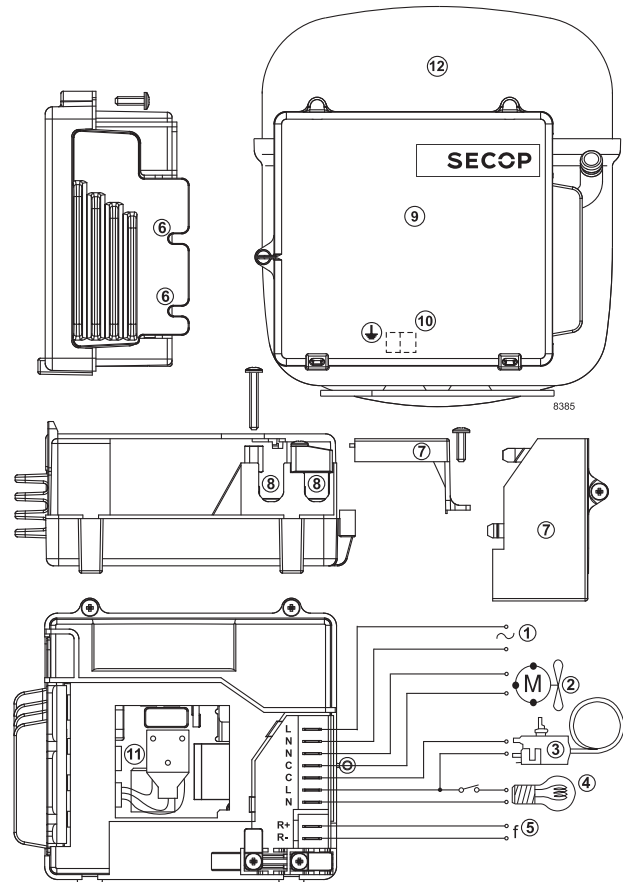

Fig. 2



## ENGLISH

The electronic unit is working within a voltage range of:

**160-254V AC, 50-60Hz or  
12/24V DC with inverter**

Max. allowable ambient temperature is 43°C. The electronic is provided with a built-in thermal protection which stops the compressor in case of thermal overload.

Use with 12/24V DC battery in a mobile application is possible by means of an inverter, 12/24V to 230V AC type, min. 300V peak voltage, min. 300W continuous power output. Examples of application - see Fig. 1

### 1. Installation (see Fig. 2)

The connector (11) of the electronic unit (9) has to be connected to the compressor (12) first. The total unit is then fitted to the compressor housing with two screws and toothed washers through the recesses in the heatsink unit (6). All other terminals (except the earth connection under point 6) and cord relief (8) are under the cover (7).

### 2. Power supply

Power supply L and N:

Power supply (1) is connected to L and N. Earth connection is connected to terminal (10) on the compressor housing (12).

### 3. Fan

Fan N and C:

A fan (2) can be connected to N and C. It will be operated with power line voltage, and cut in and out with the compressor if a conventional thermostat is used.

### 4. Thermostat connection (3) light connection (4)

The unit has 3 connection options for thermostats.

#### 4.1 Voltage signal application on-off (conventional thermostat)

Thermostats C, L and N:  
Compressor control is an *adaptive control*, see description under point 5.

#### 4.2 Application of a thermostat provided with DC signal out (min. 5V, max. 15V)

Signal input R+ and R- (5)  
(fan operation not possible):  
Connection with DC signal *on-off* to control unit, with reinforced isolation in control unit (5).  
The compressor unit runs in *adaptive control* mode, see description under point 5.

#### 4.3 Application of an electronic thermostat with frequency output (min. 5V, max. 15V)

Signal input R+ and R- (5)  
(fan connection not possible):  
The refrigerator thermostat has to supply the control unit (9) with a square signal (min. pulse width 200 µs). The input terminals are reinforced isolated. If the frequency is more than 100 Hz the compressor goes into *external reference control* mode. The compressor speed is controlled by the external frequency (*adaptive control* is disabled). The control unit remains in this mode until the power supply is disconnected. The compressor stops with an input signal below 198 Hz (min. 196 Hz, max. 199 Hz).

Compressor operation: if a frequency of above 203 Hz (min. 201 Hz, max. 205 Hz) is supplied, the compressor starts.

Example for compressor speed: external frequency multiplied by 10 (270 Hz ⇒ 2,700 rpm). If a signal with a frequency according to a speed above maximum is applied, the compressor works at maximum speed.

If a DC signal is supplied immediately after a frequency signal, the compressor speed is locked until another frequency is applied or the DC signal is removed.

### 5. Adaptive control (AEO - Adaptive Energy Optimizer)

The compressor adjusts its speed in steps to any increasing or decreasing cooling demand, within the minimum and maximum speed limits. If the thermostat switches the compressor ON: After a 60-minute running time, the speed will increase stepwise every 15 minutes, depending on the latest speed used, until the maximum is reached.

If the thermostat switches the compressor OFF: After each ON, the compressor either restarts with lower speed steps than the recently used, until the minimum is reached, or increases its speed stepwise, after a new 60-minute running time.

### 6. Earth connection

Earth connector to be applied to compressor housing (10). The electronic unit is protected by the electrical connection heatsink - toothed washer - screw - compressor housing.