

Technical information

**Fault Location on  
PL, TL, NL, FR Compressors**

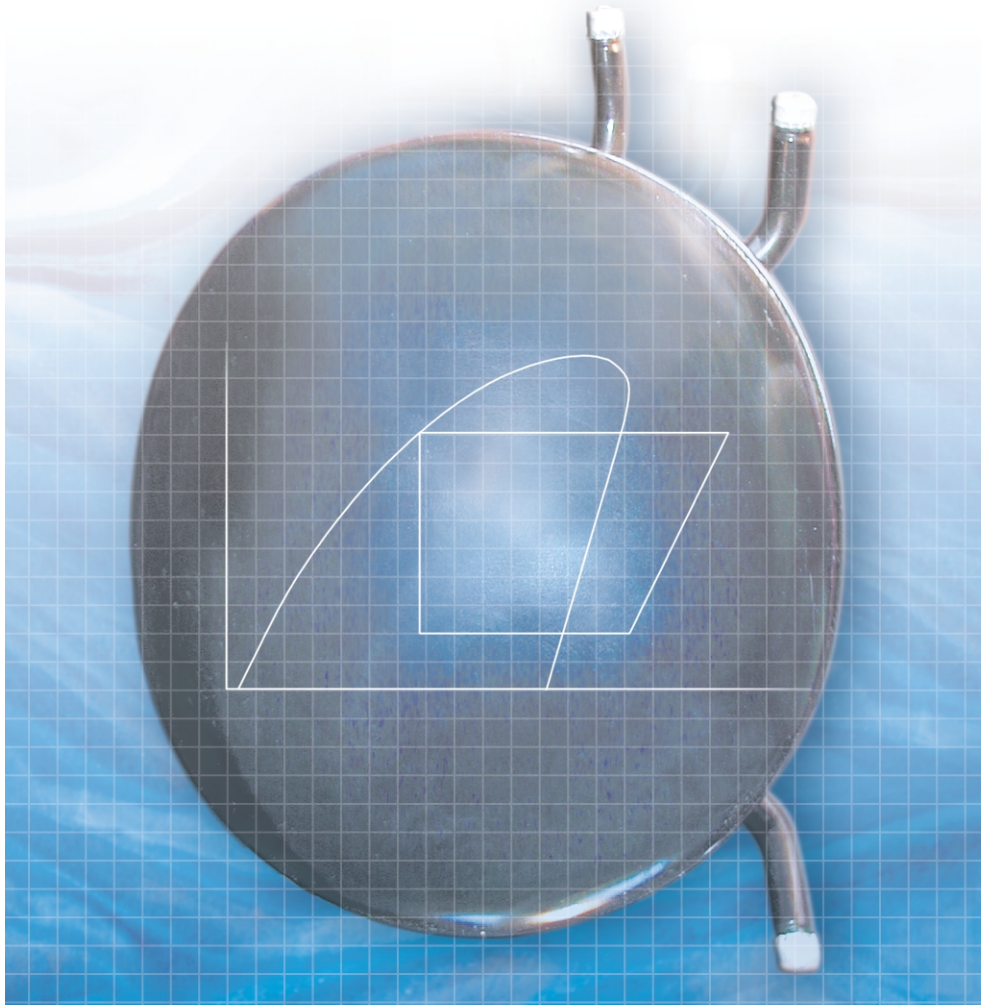

## General

This Hermetic Note is directed especially to the service network, for household appliances and similar. For detailed information on compressors see the data sheets.

Compressors type PL, TL, NL, FR and partly SC are equipped with a PTC starting device (fig. 1) or a relay and start capacitor (fig. 2). The motor protector is built into the windings.

In the event of a start failure, with a cold compressor, up to 15 minutes can elapse before the protector cuts out the compressor.

When the protector cuts out and the compressor is warm, it can take up to 1 hour before the protector cuts in the compressor again.

The compressor must not be started without the electrical equipment.

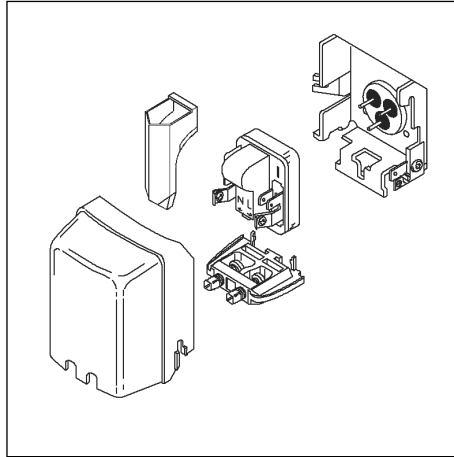

Fig. 1: PTC starting device

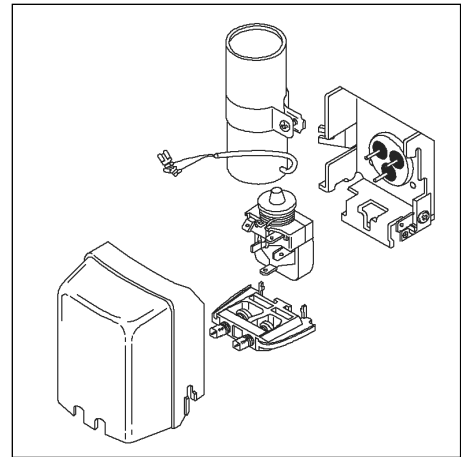

Fig. 2: Starting relay

## Fault location

Before beginning systematic fault location, a good rule is to cut the supply voltage for at least 5 minutes. This ensures that the PTC starting device has cooled off and is ready for start.

A voltage drop or blackout within the first minutes of a pull down of the appliance with cold compressor, can lead to an interlocking situation. A compressor with PTC can not start at non equalized pressure and the PTC does not cool down so fast. It can take more than 1 hour until the appliance then operates normally again.

## Electrical compressor quick check

To avoid unnecessary protector operation and consequent waiting time, it is important to carry out fault location in the sequence given below. Tests are made according to descriptions on following page.

- Remove electrical equipment
- Check electrical connection between main and start pins of compressor terminal
- Check electrical connection between main and common pins of compressor terminal
- Replace compressor, if above connection checks failed
- Else, replace electrical equipment

If the compressor still does not operate, most probably it is no electrical compressor failure. For more detailed fault location, see the tables.

**Fault location table :**

Most common fault reasons, detectable before dis-mounting compressor.

Customer claim	First analysis	Possible cause	Check	Activity (depends on result)		
No/reduced cooling	Compressor does not run	Compressor gets no or bad power supply	Voltage at plug and fuse			
			Appliance energized			
			Thermostat function			
			Cables and connections in appliance			
					Voltage at compressor terminals	
		Defective starting equipment	Relay function by shaking to hear if armature is working	Replace relay		
			Start capacitor function	Replace start capacitor		
			PTC by shaking	Replace if noise appears		
			PTC resistance 10 to 100 Ohm between M and S pin	Replace PTC		
		Compressor with PTC can not start at pressure difference	Stop time long enough for pressure equalization	Adjust thermostat difference		
		PTC defective	PTC resistance 10 to 100 Ohm between M and S pin	Replace PTC		
		Relay defective	Relay function by shaking, to hear moving of armature	Replace relay and capacitor		
		Compressor overloaded	Condenser pressure and ventilation	Ensure proper ventilation		
			Ambient temperature too high according to type label of appliance			
		Defective motor windings	Check winding resistances	Replace compressor		
	Defective protector	Check protector with ohmmeter	Replace compressor			
	Mechanically blocked compressor	Start with proper starting equipment, voltage and conditions, windings and protector OK	Replace compressor			
	Compressor runs 100%	No or low refrigerant charge	Recharge and search for leaks	Ensure leakfree system and proper charge, replace drier		
			Ambient temperature according to type label of appliance			
		Too high ambient temperature	Condenser and compressor ventilation	Ensure proper ventilation and wall distance		
		Too high condensing temperature	Recharge and search for leaks, measure suction pressure. Capillary blocked, if pressure very low			
		Capillary partly blocked	Recharge and search for leaks	Replace compressor, if still not cooling properly		
	Compressor runs on/off	Valves coked or damaged	Recharge and search for leaks			
			Thermostat not OK	Replace thermostat		
		Wrong refrigerant charge	Recharge and search for leaks	Ensure leakfree system and proper charge, replace drier		
			Ice block built up on evaporator	Check for ice on evaporator	Defrost properly	
				Thermostat function and settings	Replace thermostat	
			Internal no-frost fan function			
		Compressor trips on motor protector	Compressor load, compressor and condenser ventilation	Ensure proper ventilation and wall distance		
	Compressor voltage supply for minimum 187 V		Ensure proper power supply			
Compressor voltage supply for drop outs. Check thermostat and appliance cables for loose connections	Fix all connections					
	Motor windings resistance for partly short circuit or earth connection	Replace compressor				

Customer claim	First analysis	Possible cause	Check	Activity (depends on result)	
Noise	Rattle or humming	Tube touching cabinet	Tube placing	Bend tube to their right place, carefully	
		Compressor touching cabinet	Compressor mounting and rubber feet	Place rubber feet and mounting accessories correctly	
		Broken internal suspension spring or discharge tube	Listen to compressor with screwdriver against compressor with edge and to your ear with grip	Replace compressor, if abnormal sounds	
		Resonance	Find vibrating mounting parts	Place or fix correctly	
		Fan noise	Vibration of fan or fan mounting	Fix fan and blade, replace, if defective	
	Banging at start or stop of compressor	Compressor block hitting housing internally	Compressor overload by pressure	Compressor overload by pressure	Clean condenser if dusty. Make sure, that ventilation gaps for air circulation are satisfactory
			Fan function	Fan function	
			Refrigerant charge	Refrigerant charge	Recharge, if too high
			Pressure equalization before start and number of on/off cycles	Pressure equalization before start and number of on/off cycles	Adjust thermostat, if stop time less than 5 min
	Relay clicking frequently after start	Compressor overloaded	Ventilation to compressor and condenser. Check fan function	Ventilation to compressor and condenser. Check fan function	Clean condenser if dusty. Make sure, that ventilation gaps for air circulation are satisfactory
Relay defective			Right relay type for compressor	Replace relay, if wrong	
Fuses are blown by appliance	Short circuit in appliance	Defective cabling in appliance	All connecting cables and power supply cord for loose connections, short circuits	Fix connections properly	
		Defective thermostat	Thermostat connections	Fix connections properly	
		Ground connection	Resistance from line/neutral to earth		
	Short circuit in compressor	Defective terminals	For burns on the terminal pins	Replace electrical accessories	
		Short circuit between cables at terminals	Connectors and cables at compressor	Insulate cables and connectors	
		Short circuit in compressor motor	Resistance values in windings Resistance between terminals and earth	Replace compressor, if short circuited	
	Fuse blows at compressor start	Supply voltage too low	Supply voltage at compressor start >187 V		
		Fuse loaded by too many appliances	Total fuse load	Connect appliance to different fuse	
		Resettable fuse too quick acting	Fuse load and type	If possible replace by slightly slower type	
		Partly short circuit to earth	Resistance between terminals and earth	Replace compressor, if short circuited	
	Starting capacitor exploded	Defective relay	Relay function by shaking, to hear moving of armature	Replace relay and capacitor	
		Wrong relay type	Relay type	Replace relay and cap	
		Extremely many starts and stops of compressor	Relay type	Replace relay and cap	
Thermostat defect or differences too small			Adjust or replace thermostat		
Starting relay cap blown off	Short circuit in compressor motor	Compressor motor resistances	Replace compressor		

**Check main and start winding**

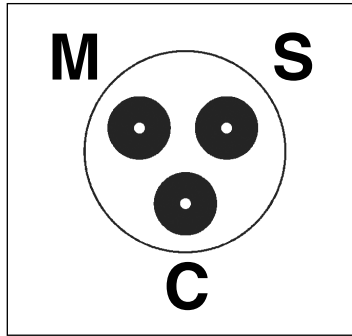

Fig. 3: Compressor terminals

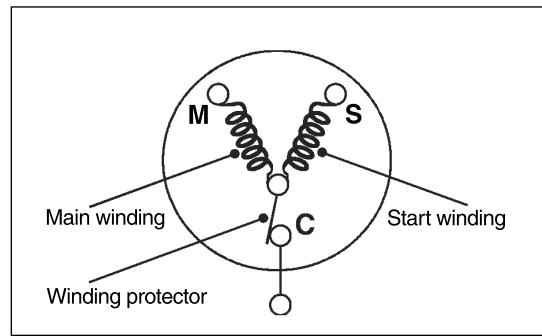

Fig. 4: Windings and protector

Resistance between pins M (main) and S (start) on compressor terminals is measured with an ohm-meter, see figure 3.

- Connection: Main and start windings normally OK
- No connection: Main or start winding defective: Replace compressor

At cold compressor (ca. 25°C) the values are ca. 10 to 100 Ohm for 220-240 V compressors. For partial short circuit detection, exact values are needed from data sheets of the specific compressor, which can be found on the Danfoss Compressors homepage.

**Check protector**

Resistance between pins M (main) and C (common) on compressor terminals is measured with an ohm-meter, see figure 3 and 4.

- Connection: Protector OK
- No connection: Compressor cold: Protector defective: Replace compressor
- Compressor hot: Protector could be OK, but cut out: Wait for reset

**Check relay**

Remove relay from compressor.

Measure connection between connectors 10 and 12 (see figure 5):

- No connection: Relay defective: Replace relay

Measure connection between connectors 10 and 11:

In normal vertical position (like mounted, solenoid upward):

- Connection: Relay defective: Replace relay
- No connection: OK

In top-down position (solenoid downward):

- Connection: OK
- No connection: Relay defective: Replace relay

**Check PTC**

Remove PTC from compressor.

Shake by hand. Pin C can slightly rattle.

- Internal rattle noise (except pin C): PTC defect: Replace PTC

Measure resistance between pins M and S, see figure 6.

Resistance value between 10 and 100 Ohm at room temperature for 220 V PTC.

- Connection: PTC working: OK
- No connection: PTC defect: Replace PTC

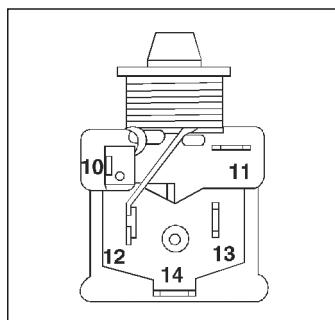

Fig. 5: Relay connections

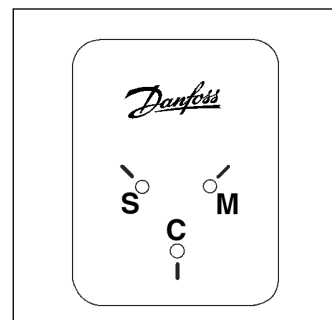
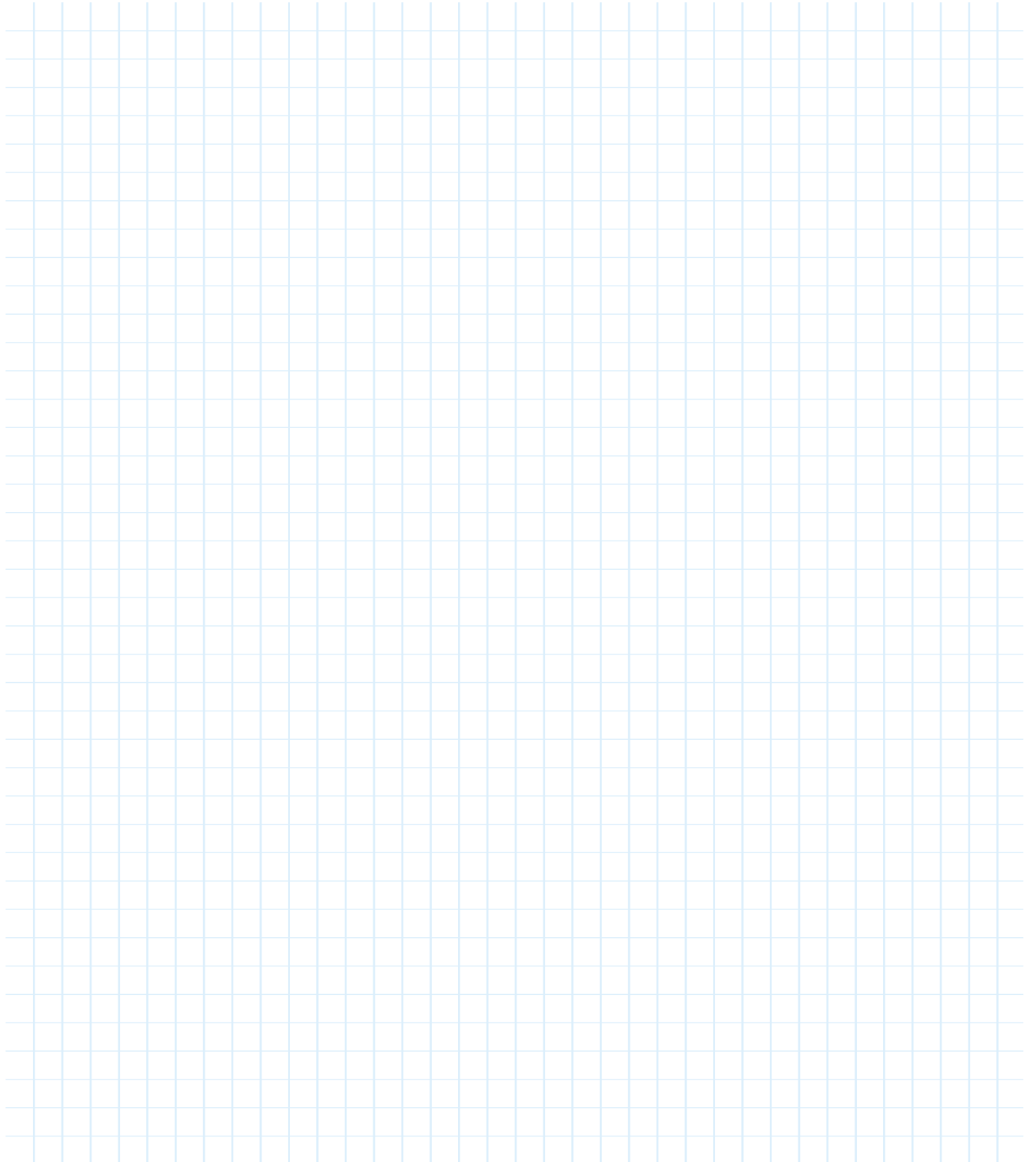

Fig. 6: PTC connections (backside)



---

Danfoss can accept no responsibility for possible errors in catalogues, brochures and other printed material. Danfoss reserves the right to alter its products without notice. This also applies to products already on order provided that such alterations can be made without subsequential changes being necessary in specifications already agreed. All trademarks in this material are property of the respective companies. Danfoss and the Danfoss logotype are trademarks of Danfoss A/S. All rights reserved.

---



## **Danfoss Compressors GmbH**

Mads-Clausen-Strasse 7  
Postfach 1443, D-24939 Flensburg  
Telefon: (0461) 4941-0  
International +49 461 4941-0  
Telefax: +49 461 44715  
Telex: 227 43 dancom d