



Application Note

Cooling in trucks

Most truck drivers are on the road for many days at a time. To keep their food and beverages cold they need refrigerators that can be built into the cab.

The BD 35F and BD 50 F compressors are tailored for the driving workplaces. They are universal for 12 and 24 V DC power supply. Besides they are unsurpassed to tolerate changeable climatic conditions and vibrations under harsh road conditions all over the world.

The BD 35F and BD 50 F compressors can be used for both refrigerators and freezers and use R134a as refrigerant.

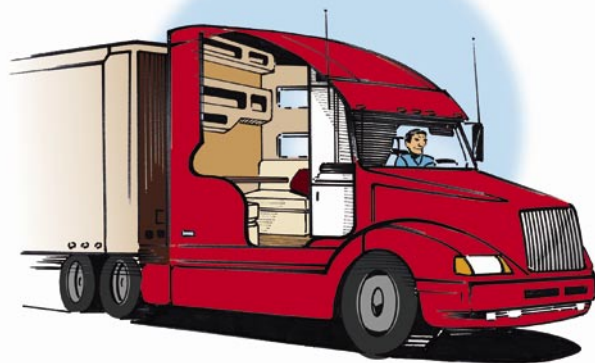

The compressors cover a capacity range from 20 to 180 W. Low, medium and high back pressure applications. (See specification sheet on the next page). Refrigerator sizes up to 160 liters and freezers up to 90 liters.

The compressors are controlled by an electronic unit including protection against overload and destructive battery discharge. The unit also features an internal voltage recording as well as calibration to the applied voltage (compressor monitoring).

Important features:

- Efficient and reliable operation under extreme conditions
- High efficiency/Low current consumption/high COP
- Compact design
- Silent operation, barely perceptible
- Variable capacity (manually adjustable or automatic)



The BD 35F and BD 50F compressors are approved according to the e4 automotive EMC standard and complies with the CE, UL and C-tick standards.

For further information please contact Danfoss.



Technical data BD35F

General

Compressor	BD35F	BD50F
Code number: Comp. without electronic unit	101Z0200	101Z1220
Code number: Electronic unit 12-24 V DC, single packing	101N0220	
Code number: Electronic unit 12-24 V DC, industrial packing, 30 pcs.	101N0221	

Application

Application	LBP/MBP/(HBP)
Evaporating temperature range °C	-30 to 0 (10)
Voltage	12 - 24 V DC
Max. voltage	31.5 V
Max. machine compartment temperature °C	55
Comp. cooling at ambient temp. 43°C	S or F ₁ *

* depending on application

Design

Displacement cm ³	2.00	2.50
Oil quantity cm ³	150	
Maximum refrigerant charge g	300	
Free gas vol. in compressor housing cm ³	870	
Weight: Compressor/Electronic unit kg	4.3/0.25	

Motor

Motor type	Variable Speed	
Resistance, all 3 windings (25°C) Ω	2.3	2.0
Approvals	E4 72/245 95/54 0277 00	

Dimensions

Height	mm	A	137
		B	135
		B1	128
		B2	73
Suction connector location/I.D. mm	C	6.2±0.09	
Process connector location/I.D. mm	D	6.2±0.09	
Discharge connector location/I.D. mm	E	5.0 +0.12/+0.20	
Compressors on a pallet pcs.		120	

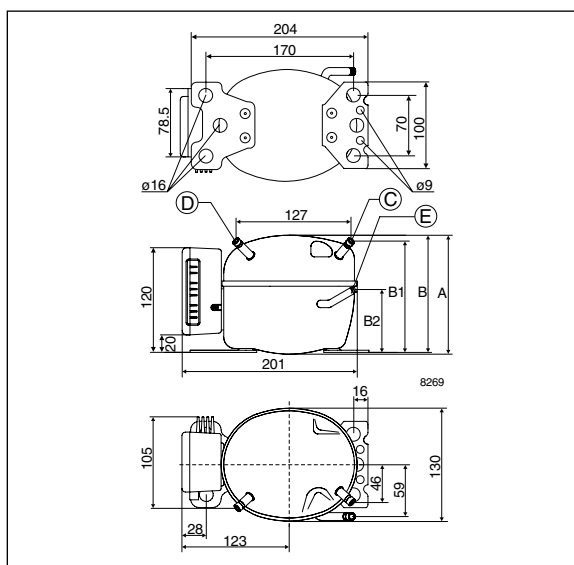

Performance data BD35F

Capacity (EN 12900/CECOMAF)

Watt

rpm \ °C	-30	-25	-23.3	-20	-15	-10	-5	0	5	10
2,000	15.8	23.9	26.9	33.1	43.8	56.6	71.7	89.9	111	136
2,500	20.2	29.9	33.5	41.2	54.6	70.7	89.7	112	139	
3,000	22.5	32.4	36.5	45.4	61.8	81.7	105	133		
3,500	26.2	35.9	40.4	50.5	69.8	93.6	122			

Power consumption

Watt

rpm \ °C	-30	-25	-23.3	-20	-15	-10	-5	0	5	10
2,000	17.6	23.4	25.3	28.7	33.6	38.3	43.0	48.0	53.4	59.5
2,500	23.3	30.9	33.3	37.8	44.1	50.2	56.2	62.3	68.7	
3,000	29.9	36.0	38.3	43.0	50.7	58.7	66.8	74.8		
3,500	36.0	42.8	45.4	50.8	59.5	68.9	78.5			

Current consumption (for 24 V applications the figures must be halved)

Amp.

rpm \ °C	-30	-25	-23.3	-20	-15	-10	-5	0	5	10
2,000	1.5	2.0	2.1	2.4	2.8	3.2	3.6	4.0	4.5	5.0
2,500	1.9	2.6	2.8	3.2	3.7	4.2	4.7	5.2	5.8	
3,000	2.5	3.0	3.2	3.6	4.2	4.9	5.6	6.2		
3,500	3.0	3.6	3.8	4.3	5.0	5.7	6.5			

COP (EN 12900/CECOMAF)

W/W

rpm \ °C	-30	-25	-23.3	-20	-15	-10	-5	0	5	10
2,000	0.90	1.02	1.06	1.15	1.31	1.48	1.67	1.87	2.08	2.29
2,500	0.87	0.97	1.01	1.09	1.24	1.41	1.60	1.80	2.02	
3,000	0.75	0.90	0.95	1.06	1.22	1.39	1.58	1.78		
3,500	0.73	0.84	0.89	1.00	1.17	1.36	1.55			

Performance data BD50F

Capacity (EN 12900/CECOMAF)

Watt

rpm \ °C	-30	-25	-23.3	-20	-15	-10	-5	0	5	10
2,000	20.1	31.0	34.9	42.8	56.3	42.2	91.6	115	144*	178*
2,500	27.0	39.0	43.4	52.7	68.9	88.9	113	144*	181*	
3,000	31.0	45.4	50.6	61.5	80.7	104	134*	171*		
3,500	38.1	53.2	59.1	71.9	95.0	124*	159*			

Power consumption

Watt

rpm \ °C	-30	-25	-23.3	-20	-15	-10	-5	0	5	10
2,000	25.1	31.8	34.0	38.2	44.7	51.3	58.3	65.8	74.2*	83.5*
2,500	34.1	40.5	42.9	47.8	55.8	64.7	74.3	84.8*	96.1*	
3,000	39.9	49.2	52.2	57.8	66.5	76.4	88.4*	104*		
3,500	50.2	59.3	62.5	69.0	80.2	93.4*	109*			

Current consumption (for 24 V applications the figures must be halved)

Amp.

rpm \ °C	-30	-25	-23.3	-20	-15	-10	-5	0	5	10
2,000	2.2	2.6	2.8	3.1	3.8	4.4	5.1	5.8	6.4*	6.9*
2,500	2.9	3.4	3.6	4.0	4.7	5.4	6.2	7.0*	7.8*	
3,000	3.5	4.2	4.4	4.9	5.6	6.5	7.4*	8.5*		
3,500	4.2	4.9	5.2	5.8	6.7	7.8*	9.0*			

COP (EN 12900/CECOMAF)

W/W

rpm \ °C	-30	-25	-23.3	-20	-15	-10	-5	0	5	10
2,000	0.80	0.98	1.03	1.12	1.26	1.41	1.57	1.75	1.94*	2.13*
2,500	0.79	0.96	1.01	1.10	1.24	1.37	1.53	1.70*	1.88*	
3,000	0.78	0.92	0.97	1.06	1.21	1.37	1.51*	1.65*		
3,500	0.76	0.90	0.95	1.04	1.19	1.32*	1.45*			

* Fan cooling of electronic unit compulsory

Test conditions

Condensing temperature 55°C
Ambient and suction gas temp. 32°C
Liquid temperature 55°C
Static cooling, 12 V DC
1 Watt = 0.86 kcal/h

EN 12900/CECOMAF

55°C

32°C

55°C

ASHRAE

55°C

32°C

32°C

Danfoss Compressors GmbH

Mads-Clausen-Strasse 7
P.O.Box 1443, D-24939 Flensburg
Phone: +49 461 4941-0
Telefax: +49 461 44715
www.danfoss.com/compressors