

Datasheets

DLE5.7CN Energy-optimized LBP/MBP R290 220-240V 50Hz

General

Code number	102H4653
Approvals	EN 60335-2-34 w. Annex AA
Compressors on pallet	100

Application

Application	LBP/MBP	
Frequency	Hz	50 60
Evaporating temperature	°C	-35 to 7.2 -
Voltage range	V	198 to 254 -
Max. condensing temperature continuous (short)	°C	55 (65) -
Max. winding temperature continuous (short)	°C	125 (135) -

Cooling requirements

Frequency	Hz	50			60		
Application		LBP	MBP	HBP	LBP	MBP	HBP
32°C		F ₂	F ₂	-	-	-	-
38°C		F ₂	F ₂	-	-	-	-
43°C		F ₂	F ₂	-	-	-	-

Remarks on application:
For evaporation temperatures higher than 0 °C do not run compressor at condensing temperatures higher 50 °C in steady state operation.

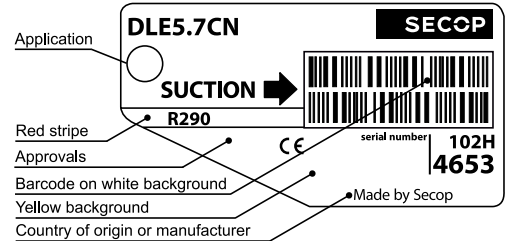

- S = Static cooling normally sufficient
- O = Oil cooling
- F₁ = Fan cooling 1.5 m/s (compressor compartment temperature equal to ambient temperature)
- F₂ = Fan cooling 3.0 m/s necessary
- SG = Suction gas cooling normally sufficient
- = not applicable in this area

Motor

Motor type	CSIR/RSIR/RSCR	
LRA (rated after 4 sec. UL984), HST LST	A	8.8 7.4
Cut in Current, HST LST	A	8.8 11.9
Resistance, main start winding (25°C)	Ω	13.5 14.3

Design

Displacement	cm ³	5.70
Oil quantity (type)	cm ³	230 (polyolester)
Maximum refrigerant charge	g	150
Free gas volume in compressor	cm ³	1465
Weight without electrical equipment	kg	8.0

Dimensions

Height	mm	A	175
		B	169
		B1	-
		B2	-
Suction connector	location/I.D. mm angle	C	8.2 18°
	material comment		Copper Rubber plug
Process connector	location/I.D. mm angle	D	6.2 60°
	material comment		Copper Rubber plug
Discharge connector	location/I.D. mm angle	E	6.2 25°
	material comment		Copper Rubber plug
Oil cooler connector	location/I.D. mm angle	F	-
	material comment		-
Connector tolerance	I.D. mm		±0.09
Remarks:			

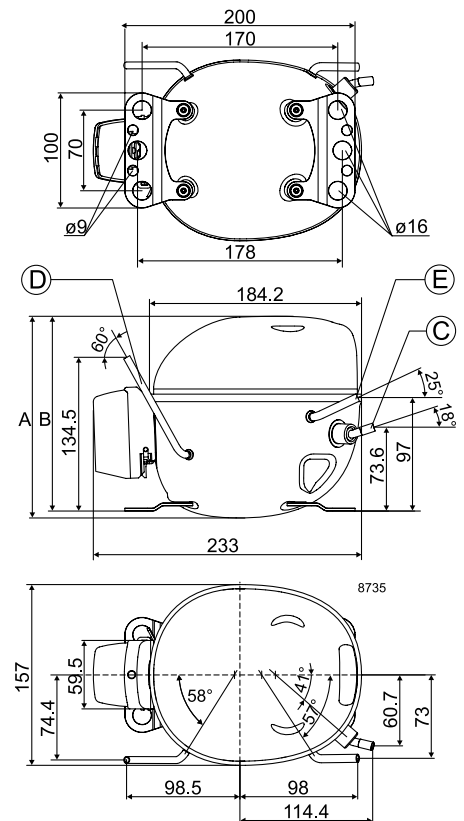

EN 12900 LBP 220V, 50Hz, CSIR/RSIR, fan cooling F₂

Evap. temp. in °C	-45	-40	-35	-30	-25	-23.3	-20	-15	-10	-6.7	-5	0	5	7.2	10	15	20
Capacity in W			169	215	267	287	328	400	483	547	582	697	832	897			
Power cons. in W			145	162	179	184	194	208	222	230	234	245	256	260			
Current cons. in A			1.13	1.17	1.21	1.23	1.25	1.30	1.34	1.36	1.38	1.42	1.45	1.47			
COP in W/W			1.17	1.33	1.50	1.56	1.69	1.92	2.18	2.38	2.49	2.84	3.25	3.45			

EN 12900 MBP 220V, 50Hz, CSIR/RSIR, fan cooling F₂

Evap. temp. in °C	-45	-40	-35	-30	-25	-23.3	-20	-15	-10	-6.7	-5	0	5	7.2	10	15	20
Capacity in W			158	203	252	271	309	376	454	513	546	654	780	841			
Power cons. in W			148	167	184	190	201	218	233	243	248	262	276	281			
Current cons. in A			1.13	1.18	1.23	1.24	1.27	1.32	1.37	1.40	1.42	1.47	1.52	1.54			
COP in W/W			1.07	1.22	1.37	1.42	1.54	1.73	1.95	2.11	2.20	2.49	2.83	2.99			

ASHRAE LBP 220V, 50Hz, CSIR/RSIR, fan cooling F₂

Evap. temp. in °C	-45	-40	-35	-30	-25	-23.3	-20	-15	-10	-6.7	-5	0	5	7.2	10	15	20
Capacity in W			168	220	277	298	341	415	501	566	603	722	862	930			
Power cons. in W			149	169	188	195	208	227	245	258	264	282	300	308			
Current cons. in A			1.15	1.20	1.26	1.28	1.32	1.38	1.45	1.50	1.52	1.59	1.67	1.70			
COP in W/W			1.12	1.30	1.47	1.53	1.64	1.83	2.04	2.20	2.28	2.56	2.87	3.03			

ASHRAE MBP/HBP 220V, 50Hz, CSIR/RSIR, fan cooling F₂

Evap. temp. in °C	-45	-40	-35	-30	-25	-23.3	-20	-15	-10	-6.7	-5	0	5	7.2	10	15	20
Capacity in W			150	197	247	266	304	370	447	505	537	643	766	827			
Power cons. in W			148	167	186	193	205	224	243	255	261	279	296	304			
Current cons. in A			1.15	1.20	1.26	1.28	1.32	1.38	1.45	1.50	1.52	1.59	1.67	1.70			
COP in W/W			1.02	1.18	1.33	1.38	1.48	1.65	1.84	1.98	2.06	2.31	2.59	2.72			

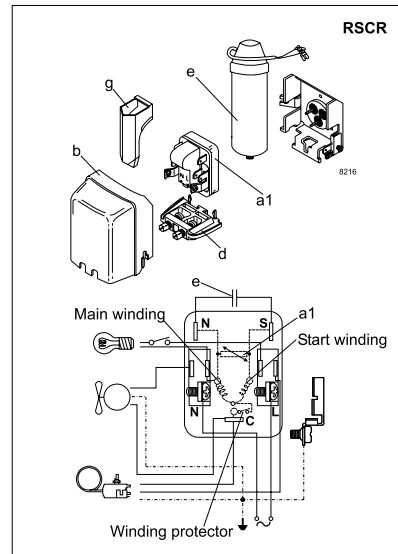
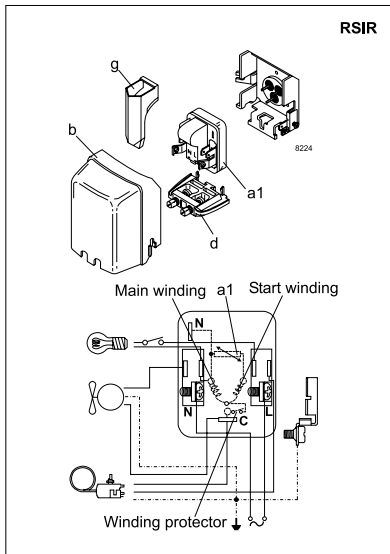
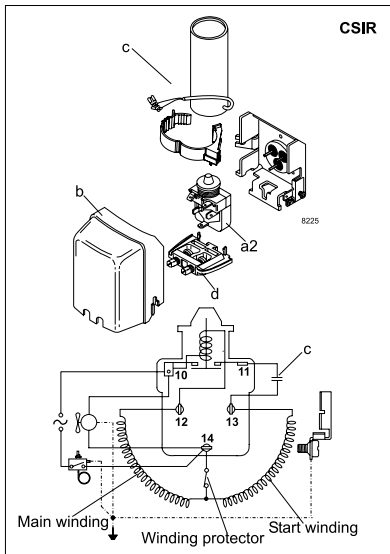

Accessories for	DLE5.7CN	Figure	Code number
PTC starting device	6.3 mm spade connectors	a1	-
	4.8 mm spade connectors		-
ePTC starting device	4.8 mm spade connectors		103N0050
Starting relay	6.3 mm spade connectors	a2	117U7015
Start. capacitor 80 µF	6.3 mm spade connectors	c	117U5015
Cover		b	103N0491
Run capacitor 5 µF (optional)	6.3 mm spade connectors	e	-
	4.8 mm spade connectors		117-7129
Cord relief		d	103N1010
Protection screen for PTC		g	-

Test conditions	EN 12900		ASHRAE	
	LBP	MBP	LBP	MBP
Condensing temperature	40°C	45°C	54.4°C	54.4°C
Ambient temperature	32°C	32°C	32.2°C	35°C
Suction gas temperature	20°C	20°C	32.2°C	35°C
Liquid temperature	no subcooling		32.2°C	46.1°C

Mounting accessories	Code number	
Bolt joint for one comp.	Ø: 16 mm	118-1917
Bolt joint in quantities	Ø: 16 mm	118-1918
Snap-on in quantities	Ø: 16 mm	118-1919

Danfoss can accept no responsibility for possible errors in catalogues, brochures and other printed material. Danfoss reserves the right to alter its products without notice. This also applies to products already on order provided that such alterations can be made without subsequent changes being necessary in specifications already agreed. All trademarks in this material are property of the respective companies. Danfoss and the Danfoss logotype are trademarks of Danfoss A/S. All rights reserved.