

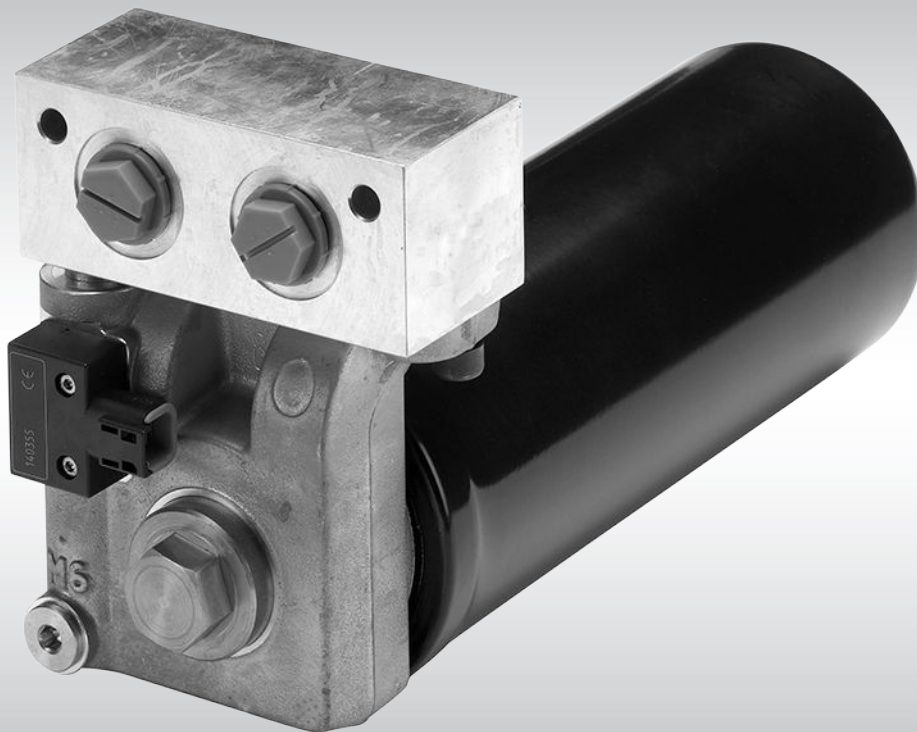

Technical Information

Hydrostatics

# External Remote Charge Pressure Filter



**Revision History***Table of Revisions*

<b>Date</b>	<b>Changed</b>	<b>Rev</b>
Mar 2014	Converted to Danfoss layout - DITA CMS	BA
Nov 2010		AB

**Contents****General Information**

Introduction.....	4
Features.....	4

**System Design Parameters**

Filtration.....	5
Remote charge pressure filtration.....	5
Operating pressure.....	6
Differential pressure and $\beta$ -ratio.....	7
Bypass valve and bypass sensor.....	7
Bypass valve function.....	7
Filter Bypass Valve Characteristic (completely blocked Filter element).....	8
Bypass sensor clearance.....	10
Dimensions.....	11

## General Information

### Introduction

For more than 40 years, Danfoss has been developing state-of-the-art components and systems for mobile machinery used in off-highway operations around the world. We have become a preferred supplier by offering the best of what really matters: The hardware inside your vehicle application.

### Features

- Common filter head
- 3 different filter sizes
- Compatible with
  - H1 P
  - S 90
  - S 42
  - S 40
- Integrated functionality
  - Bypass valve
  - Electric contamination indicator
- Serviceability
  - No extra space for element replacement needed, (side way removal possible)

**System Design Parameters**
**Filtration**
**Remote charge pressure filtration**

The remote pressure filter head is designed with a filter bypass valve and noncontacting bypass sensor. The pressure differential acting on the filter element also acts on a spring biased bypass spool. This spool is designed with a magnetic area. When a certain spool position is reached, the magnet closes a switch in the bypass sensor which allows R2 to be in parallel with R1. This occurs without any mechanical contact between the spool and the bypass sensor.

The position of the bypass spool is indicated by the change in the measured sensor resistance. The change in resistance occurs when R2 is switched in and out of the circuit. When the filter is not being bypassed, the nominal measured resistance is 510 ohms. When the switch is closed, the nominal measured resistance is 122 ohms.

The bypass spool is designed so the bypass sensor switch will be closed before oil bypasses the filter element. This gives the machine operator an indication that the filter is very close to bypassing and a filter replacement is required.

For cold start conditions, it is typical that the filter may bypass for a short amount of time while the oil is warming up. At normal operating oil temperatures, a system that does not yet need a filter replacement will operate in the non-bypass mode. The addition of an oil temperature sensor and additional control logic, is recommended to properly determine if a filter replacement is required.

**Technical data, pressures**

Filter bypass sensor switch closure	$\Delta p$ 3.7 - 5.1 bar [54 - 74 psi]
Bypass valve	$\Delta p$ 5.6 $\pm$ 0.9 bar [80 $\pm$ 13 psi]
T000 159E	

**Technical data, electric**

Max. voltage	48 V
Max. power	0.6 W
Switch open	510 $\Omega$
Switch closed	122 $\Omega$
Resistor tolerance	1 %
Temperature range	-20 °C $\div$ +100 °C [-4 °F $\div$ +212 °C]
IP Rating (IEC 60 529) + DIN 40 050, part 9 with mating connector	IP 69K
T000 160E	

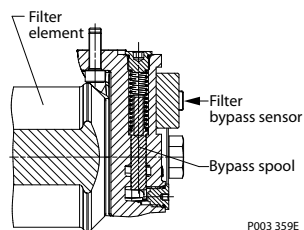
**Integral filter head with filter bypass sensors**

**System Design Parameters**

*Schematic*

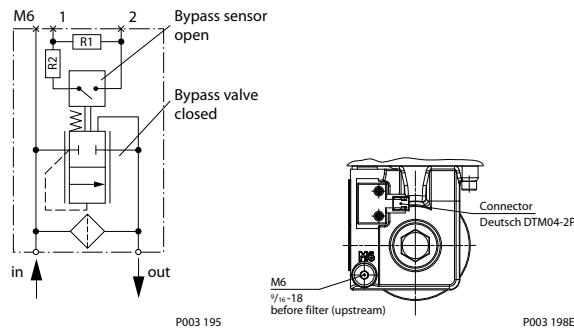

*Pinout*

Pin	Description
1	Voltage
2	Ground
T000 162E	

*Alternative pinout*

Pin	Description
1	Ground
2	Voltage
T000 163E	

*Pin location*

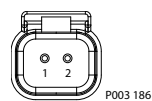

For device electrical schematic, see Schematic, page 5.

*H1 Filter bypass sensor mating connector parts list*

Description	Quantity	Ordering number
Mating connector	1	Deutsch DTM06-2S
Secondary wedge lock	1	Deutsch WM-2S
Socket terminal	2	Deutsch 0462-201-20141
Danfoss mating connector kit	1	11031205
T000 164E		

**Operating pressure**

	Unit	
Maximum working pressure	bar [psi]	45 [653]
Maximum pressure (cold start)		55 [798]

**System Design Parameters**
**Differential pressure and  $\beta$ -ratio**

Nominal flow at 30 mm <sup>2</sup> /s and $\Delta p$ 0.5 bar [7.3 psi] (clean filter element only)		Min $\beta$ ratio
Short	60 l/min	$\beta_{7.5(c)} = 75$ ( $\beta_{5(c)} \geq 10$ )
Medium	80 l/min	
Long	105 l/min	

**Bypass valve and bypass sensor**

A common spool is used to activate both the bypass sensor and bypass function leading to the assurance that the bypass sensor will be closed before the bypass is engaged. The bypass sensor occurs at a filter pressure drop of 4.4 +/-0.7 bar. The minimum pressure drop between bypass sensor and open bypass is 1.0 bar.

*Bypass sensor*

	Differential pressure [bar]
Bypass sensor engages at	4.4 +/- 0.7
T301 041E	

***Bypass valve function***

The bypass valve opens at 1.2 bar +/- 0.2 bar above bypass sensor engagement pressure.

System Design Parameters

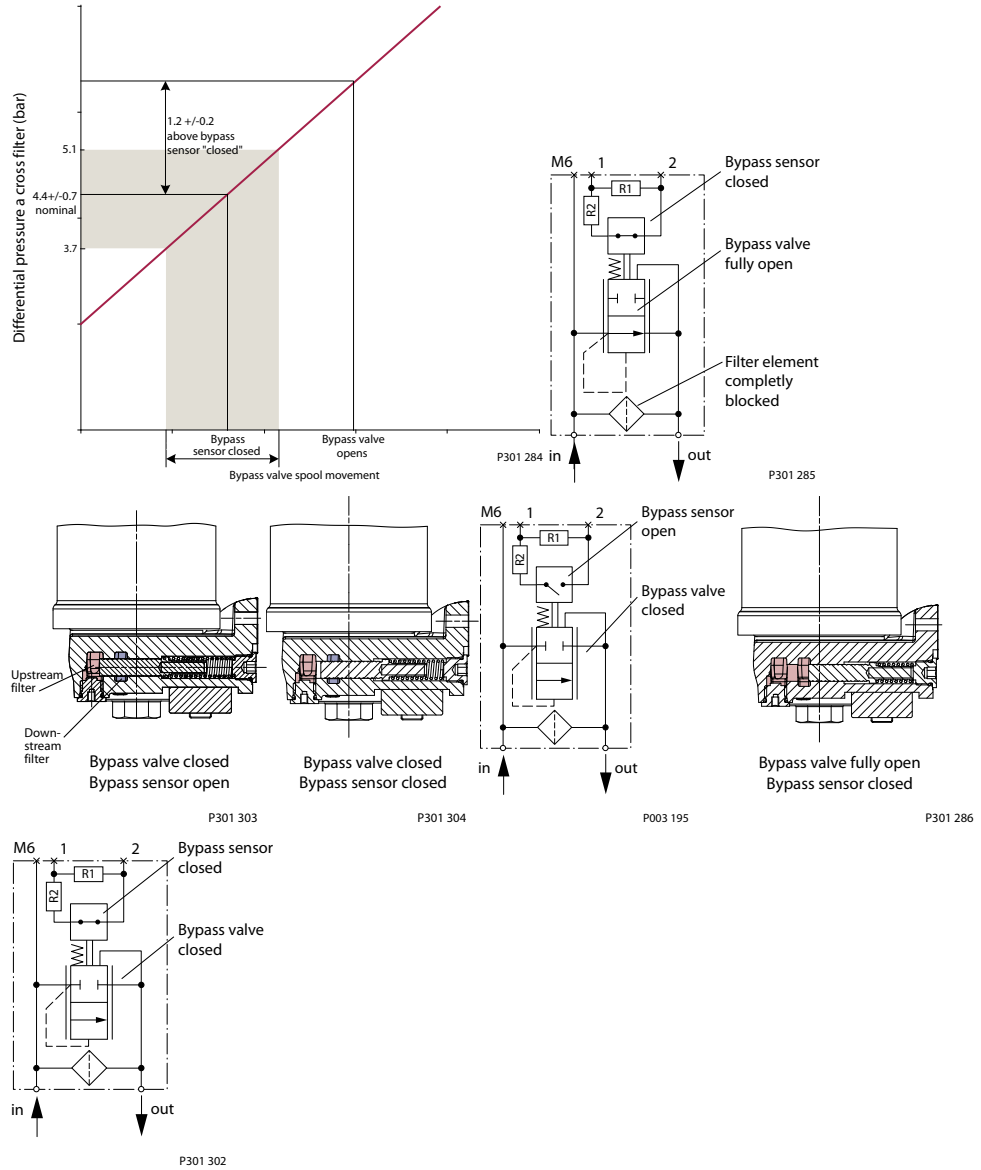

**Filter Bypass Valve Characteristic (completely blocked Filter element)**

Below diagram shows the differential pressure between filter "in" and "out" with a filter element completely blocked, so that all flow runs across the filter bypass valve.



System Design Parameters

Remote filter 11001484, short, 60 l/min, and 11001485, medium 80 l/min

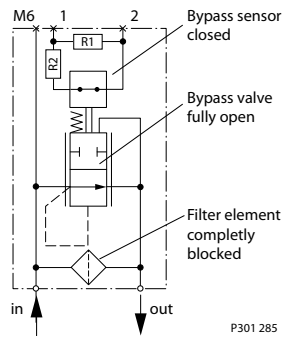
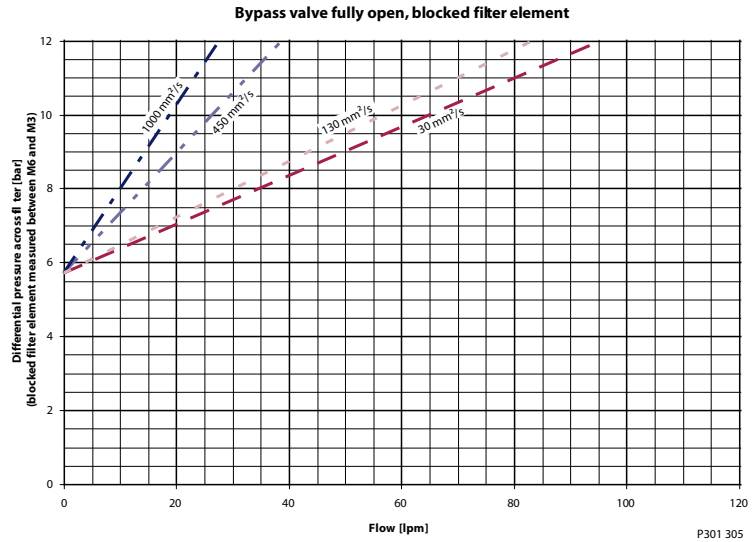

Remote filter 110048860, long, 105 l/min

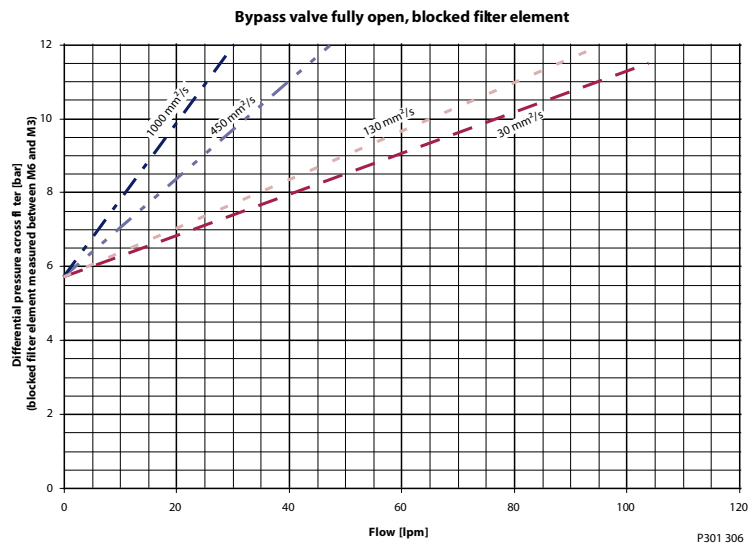

**System Design Parameters**

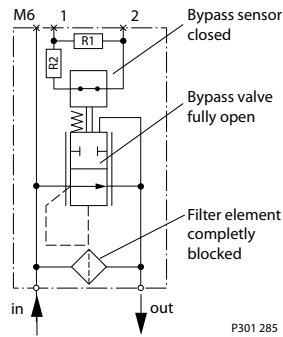

**Bypass sensor clearance**

The bypass sensor is activated by the magnetic bypass valve. For proper function it is required to have no steel parts around the sensor within in below radius. No steel parts are allowed within a radius of 150 mm [5.91 in]. Moving steel devices or parts are not allowed within a radius of 250 mm [9.84 in].

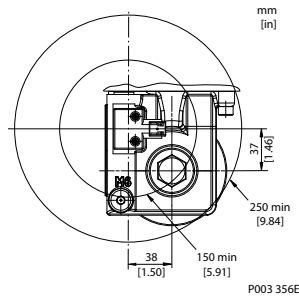

System Design Parameters

Dimensions

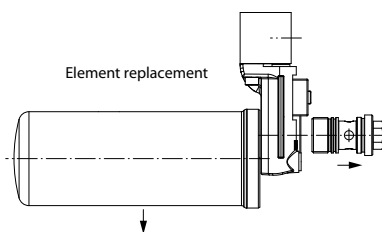
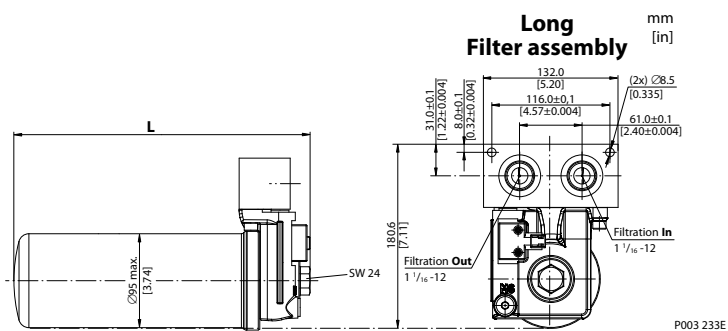
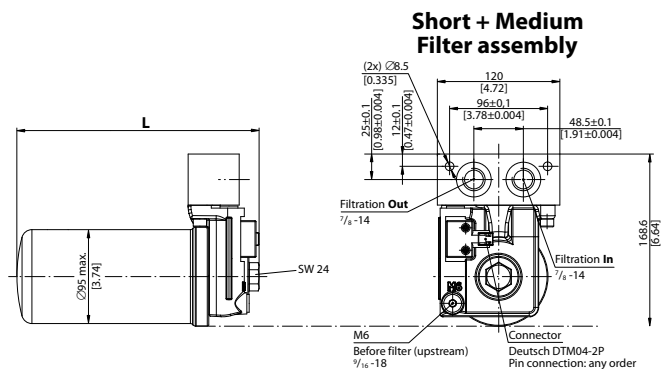

Filter assembly		In and out port size	L max. mm [inch]	Replacement element
Short	11001484	7/8 -14	205 [8.07]	11004917
Medium	11001485	7/8 -14	233 [9.17]	11004918
Long	11048860	1 1/16 -12	292 [11.49]	11004919



**Products we offer:**

- Bent Axis Motors
- Closed Circuit Axial Piston Pumps and Motors
- Displays
- Electrohydraulic Power Steering
- Electrohydraulics
- Hydraulic Power Steering
- Integrated Systems
- Joysticks and Control Handles
- Microcontrollers and Software
- Open Circuit Axial Piston Pumps
- Orbital Motors
- PLUS+1® GUIDE
- Proportional Valves
- Sensors
- Steering
- Transit Mixer Drives

**Danfoss Power Solutions** is a global manufacturer and supplier of high-quality hydraulic and electronic components. We specialize in providing state-of-the-art technology and solutions that excel in the harsh operating conditions of the mobile off-highway market. Building on our extensive applications expertise, we work closely with our customers to ensure exceptional performance for a broad range of off-highway vehicles.

We help OEMs around the world speed up system development, reduce costs and bring vehicles to market faster.

Danfoss – Your Strongest Partner in Mobile Hydraulics.

**Go to [www.powersolutions.danfoss.com](http://www.powersolutions.danfoss.com) for further product information.**

Wherever off-highway vehicles are at work, so is Danfoss.

We offer expert worldwide support for our customers, ensuring the best possible solutions for outstanding performance. And with an extensive network of Global Service Partners, we also provide comprehensive global service for all of our components.

Please contact the Danfoss Power Solution representative nearest you.

**Comatrol**

[www.comatrol.com](http://www.comatrol.com)

**Schwarzmueller-Inverter**

[www.schwarzmueller-inverter.com](http://www.schwarzmueller-inverter.com)

**Turolla**

[www.turollaocg.com](http://www.turollaocg.com)

**Valmova**

[www.valmova.com](http://www.valmova.com)

**Hydro-Gear**

[www.hydro-gear.com](http://www.hydro-gear.com)

**Daikin-Sauer-Danfoss**

[www.daikin-sauer-danfoss.com](http://www.daikin-sauer-danfoss.com)

Local address:

**Danfoss Power Solutions US Company**  
2800 East 13th Street  
Ames, IA 50010, USA  
Phone: +1 515 239 6000

**Danfoss Power Solutions GmbH & Co. OHG**  
Krokamp 35  
D-24539 Neumünster, Germany  
Phone: +49 4321 871 0

**Danfoss Power Solutions ApS**  
Nordborgvej 81  
DK-6430 Nordborg, Denmark  
Phone: +45 7488 2222

**Danfoss Power Solutions (Shanghai) Co. Ltd.**  
Building #22, No. 1000 Jin Hai Rd  
Jin Qiao, Pudong New District  
Shanghai, China 201206  
Phone: +86 21 3418 5200

Danfoss can accept no responsibility for possible errors in catalogues, brochures and other printed material. Danfoss reserves the right to alter its products without notice. This also applies to products already on order provided that such alterations can be made without subsequential changes being necessary in specifications already agreed. All trademarks in this material are property of the respective companies. Danfoss and the Danfoss logotype are trademarks of Danfoss A/S. All rights reserved.