

Technical Information

CMSS1000

# CAN Multi-Sonic Sensor



**Revision history***Table of revisions*

<b>Date</b>	<b>Changed</b>	<b>Rev</b>
July 2015	Source addresses and resistor values table corrected	CA
Mar 2014	Various updates	BB
Mar 2014	First edition	AA

**Contents**
**Product overview**

CMSS1000 CAN multi-sonic sensor.....	4
Features and options.....	4

**User liability and safety statements**

OEM responsibility.....	5
Machine wiring guidelines.....	5
Machine welding guidelines.....	6

**Theory of operation**

CMSS1000 CAN multi-sonic sensor.....	7
Modes of operation.....	7
Ground mode.....	7
String line mode.....	7
Ranges for string line and ground sensing.....	8

**Ordering information**

CMSS1000 ordering information.....	9
------------------------------------	---

**Product installation**

Dimensions.....	10
Sensor mounting instructions.....	10
Power switch.....	11
Quick mount and release.....	11
LEDs.....	11
Deviation indication.....	11

**Accessories**

Temperature bail.....	12
-----------------------	----

**Connector**

Connector pin assignments.....	13
--------------------------------	----

**Sensor configuration**

Baud rate .....	14
Identifier length.....	14
Address claim.....	14
Broadcast messages.....	14

**Source Address (SA)**

Source addresses and resistor values.....	15
---	----

**Controller Area Network (CAN) Message Protocols**

Mode.....	16
Survey.....	16
Offset.....	17
LED.....	17
Data.....	18

**Specifications**

Electrical.....	19
Mechanical.....	19
Ultrasonic performances.....	19
Environmental.....	19

## Product overview

### CMSS1000 CAN multi-sonic sensor

This CMSS1000 is an elevation sensor designed for superior performance and flexibility in grade control applications. It incorporates six ultrasonic sensors set to an optimized frequency that results in high precision output signals. The width of the six sensors allows for implementation of a string line sensing mode for steering and elevation control. It has LED panels on two sides that give the operator a visual indication of where the sensor is in relation to the active set point of the application.

The sensor includes a reference bail for optimum temperature and wind compensation. The bail is firmly held in place by magnets and designed to safely release upon contact rather than break or bend. The bail can be easily removed and stored in an alternate position when the sensor is not in use.

The quarter-turn, cam lock quick mount allows for a one handed installation/removal of the sensor that requires no tools. The sensor is rated IP67.

### Features and options

- Ultrasonic sensing technology
- Multiple sensors
- PLUS+1® Compliant
- Capable of string line or ground sensing
  - String line sensing range: 20 to 40 cm, 15 cm steering
  - Ground sensing range: 20 to 100 cm
- CAN 2.0 B compliant
- Supports 11 bit and 29 bit message ID
- Data height resolution 0.1 mm
- Temperature bail for temperature and wind compensation
- LED grade indicators for high/on/low operator feedback

## User liability and safety statements

### OEM responsibility

The OEM of a machine or vehicle in which Danfoss products are installed has the full responsibility for all consequences that might occur. Danfoss has no responsibility for any consequences, direct or indirect, caused by failures or malfunctions.

- Danfoss has no responsibility for any accidents caused by incorrectly mounted or maintained equipment.
- Danfoss does not assume any responsibility for Danfoss products being incorrectly applied or the system being programmed in a manner that jeopardizes safety.
- All safety critical systems shall include an emergency stop to switch off the main supply voltage for the outputs of the electronic control system. All safety critical components shall be installed in such a way that the main supply voltage can be switched off at any time. The emergency stop must be easily accessible to the operator.

### Machine wiring guidelines

- Protect wires from mechanical abuse, run wires in flexible metal or plastic conduits.
- Use 85° C (185° F) wire with abrasion resistant insulation and 105° C (221° F) wire should be considered near hot surfaces.
- Use a wire size that is appropriate for the module connector.
- Separate high current wires such as solenoids, lights, alternators or fuel pumps from sensor and other noise-sensitive input wires.
- Run wires along the inside of, or close to, metal machine surfaces where possible, this simulates a shield which will minimize the effects of EMI/RFI radiation.
- Do not run wires near sharp metal corners, consider running wires through a grommet when rounding a corner.
- Do not run wires near hot machine members.
- Provide strain relief for all wires.
- Avoid running wires near moving or vibrating components.
- Avoid long, unsupported wire spans.
- Ground electronic modules to a dedicated conductor of sufficient size that is connected to the battery (-).
- Power the sensors and valve drive circuits by their dedicated wired power sources and ground returns.
- Twist sensor lines about one turn every 10 cm (4 in).
- Use wire harness anchors that will allow wires to float with respect to the machine rather than rigid anchors.

#### **Caution**

---

Unused pins on mating connectors may cause intermittent product performance or premature failure. Plug all pins on mating connectors.

---

#### **Warning**

---

Unintended movement of the machine or mechanism may cause injury to the technician or bystanders. Improperly protected power input lines against over current conditions may cause damage to the hardware. Properly protect all power input lines against over-current conditions.

---

**User liability and safety statements****Machine welding guidelines**** Warning**

---

High voltage from power and signal cables may cause fire or electrical shock, and cause an explosion if flammable gasses or chemicals are present.

Disconnect all power and signal cables connected to the display before performing any electrical welding on a machine.

---

The following is recommended when welding on a machine equipped with electronic components:

- Turn the engine off.
- Remove electronic components from the machine before any arc welding.
- Disconnect the negative battery cable from the battery.
- Do not use electrical components to ground the welder.
- Clamp the ground cable for the welder to the component that will be welded as close as possible to the weld.

## Theory of operation

### CMSS1000 CAN multi-sonic sensor

Each sensor has six transducers that are used to achieve optimal elevation and steering control. Each transducer takes two measurements at each sample cycle: one for temperature compensation and one for the target measurement. Ultrasonic transducer signals are affected by temperature. A reference bail is mounted in the path of the transducer, running the entire length of the sensor to compensate for temperature errors. The sensor then responds to fluctuations caused by wind gusts and vehicle exhaust. Accounting for temperature compensation readings without breaks in measurement results in an overall faster sensor response time.

When the transducer sends out a signal, the signal first hits the temperature bail and provides an echo that is reflected back to the transducer. The signal then continues on to the target and a second echo is reflected back to the transducer. Because the distance to the bail is constant, it is used to compensate the second echo for temperature errors.

The sensor detects when the temperature bail is not present and sends a message to the system application that temperature compensation is not available and accuracy of the sensor may be compromised. When the temperature bail is replaced and the operator's hand is removed from the temperature bail echo region, the sensor automatically recalibrates for temperature compensation.

## Modes of operation

### Ground mode

When the multi-sonic sensor is configured to operate in ground mode, the sensor measures distance from the sensor to the target. To accurately measure height, the sensor must be placed perpendicular to the target at a distance between 20cm and 100cm.

### String line mode

When the multi-sonic sensor is configured to operate in string line mode, the sensor measures distance from the sensor to the string (string height), and where the string is relative to one edge of the sensor (string position).

To accurately measure height, and position, the sensor must be placed perpendicular to the string at a distance between 20 cm and 40 cm. Also, the string must be at least one inch off the ground.

The string height is calculated by triangulating the distance from the two ultrasonic transducers sensing the shortest distance. This approach allows for a much better accuracy due to trigonometric errors inherent when only the height measurement from a single sensor with the shortest distance is used.

The string position is calculated using a weighted average algorithm which allows the sensor to determine the position of the string with much better resolution. The string position is transmitted in two different formats:

- High resolution format transmits a number between 0 and 1500 which corresponds to 0 to 150.0 mm.
- Low resolution format transmits a number between 0 and 11 which indicates the string is either under a ultrasonic transducers, or between two transducers.

**Theory of operation**

**Ranges for string line and ground sensing**

*CMSS1000 ranges for string line (left drawing) and ground sensing (right drawing)*

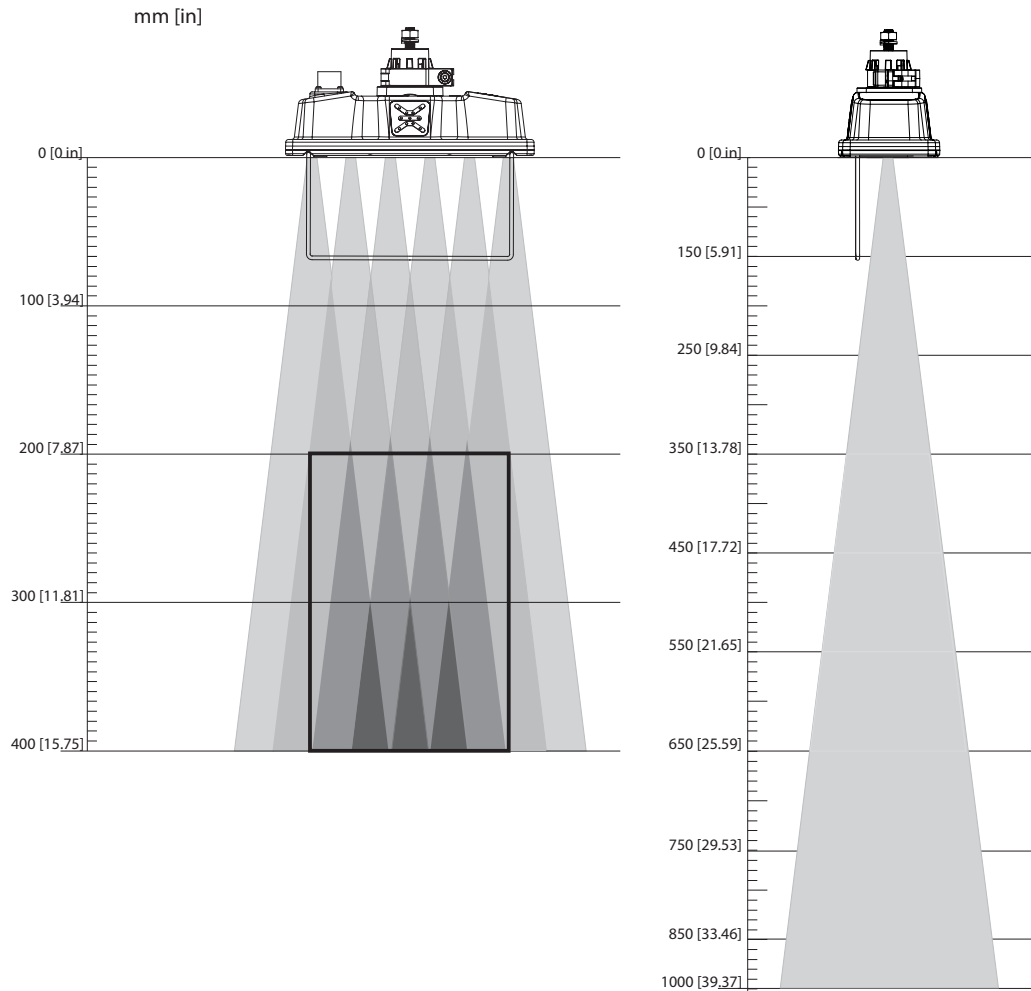

P200 124

Stringline must be at least 25.4 mm (1 in) above the ground.



---

**Technical Information    CMSS1000 CAN Multi-Sonic Sensor**

---

**Ordering information****CMSS1000 ordering information**

*CMSS1000 Wireless Multi-Sonic Sensor and related products part numbers*

<b>Description</b>	<b>Danfoss part number</b>
CMSS1000	11135818
CG150-2 CAN/USB Gateway	11153051
Temperature Bail	11125810
Quick Mount	11143887

**Product installation**

**Dimensions**

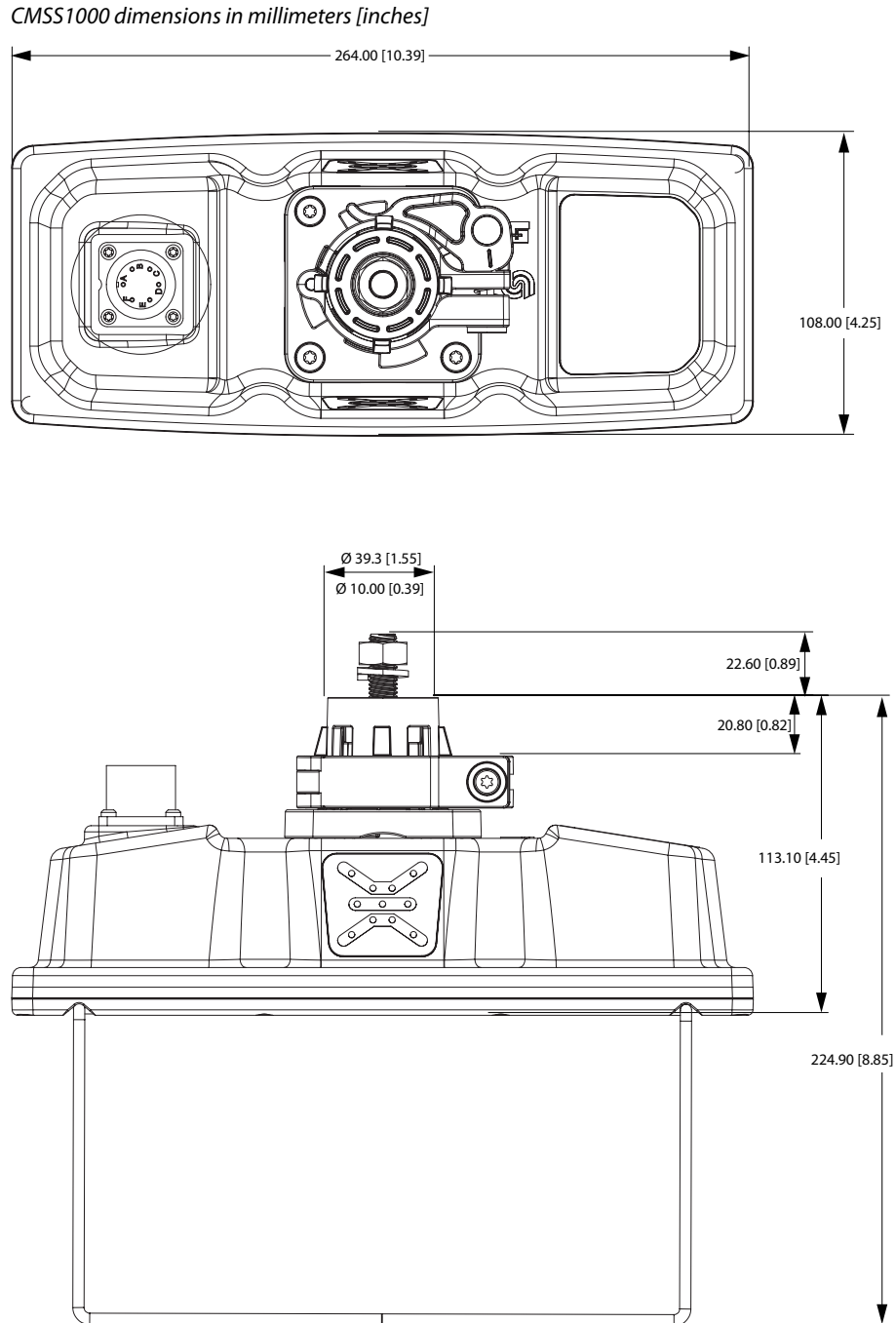

P200 123

**Sensor mounting instructions**

Sensor should be rigidly mounted to the machine, placed so the target surface is not obstructed. Care should be taken to place sensor parallel to the target surface and in the working range of the sensor.

**Product installation**

**Power switch**

To turn on the CMSS1000 CAN multi-sonic sensor: Press the power switch. All Leds flash once to indicate power up.

To turn off the sensor: Press and hold the switch until the LEDs turn off.

**Quick mount and release**

The CMSS1000 CAN multi-sonic sensor is designed for quick mounting and removal.

- Quick mount and release - requires no tools to remove the sensor from the mount.
- Locking tab prevents the sensor from falling off if the release lever is inadvertently opened.

*Locking tab*

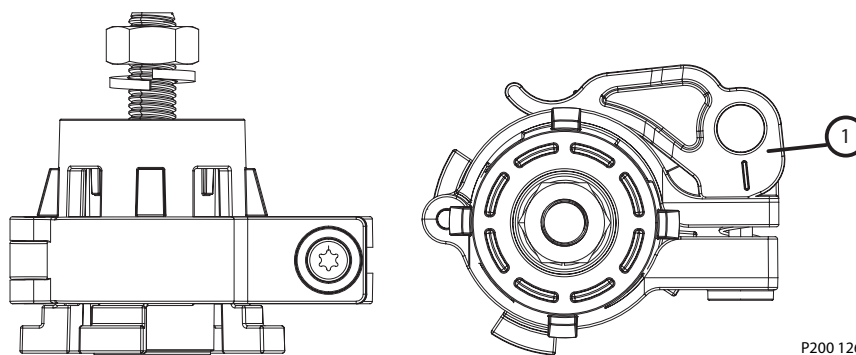

**1. Locking tab**

P200 126

Keep quick mount assembly free of dirt to prevent excessive wear.

**LEDs**

All LEDs provide visual indication of sensor status for the machine operators.

**Deviation indication**

LEDs on both sides of the CMSS1000 multi-sonic sensor provide a visual indication of sensor position and status for the machine operators. The deviation LEDs consist of three sections; up arrow, on grade, and down arrow. These LEDs are under software control and each section is controlled by the LED Command CAN message.

*Deviation indication LEDs*

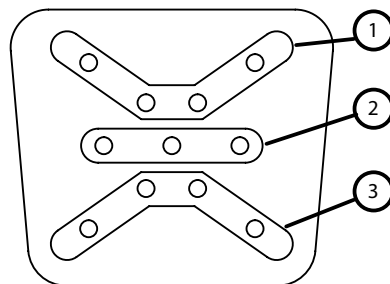

- 1. Down arrow**
- 2. On grade**
- 3. Up arrow**

P200 117

## Accessories

### Temperature bail

A reference bail for optimum temperature and wind compensation is included. The temperature bail is designed to magnetically lock firmly in place when in use and safely release upon contact rather than break or bend. The bail can be easily removed in the presence of a physical obstruction that could potentially bend or break the bail. If an object runs into the bail, the bail will detach from the sensor to prevent damage.

The sensor has cutouts on the underside for the bail to be repositioned from normal use into a flat position for storage. The magnets retain the bail during storage.

*CMSS1000 temperature bail in use, stored, removed*

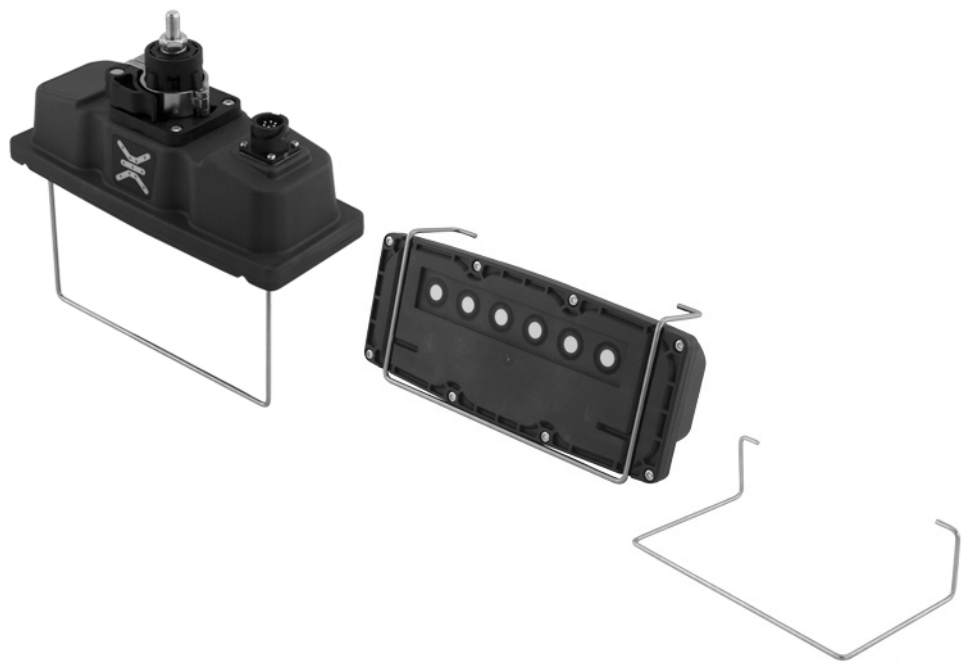

F200 041

**Connector**
**Connector pin assignments**

CMSS1000 uses a 6 pin connector for connecting the sensor to the machine controls. The table below identifies the pin numbers and describes the input/output types of each pin of the connector.

*6 pin connector*

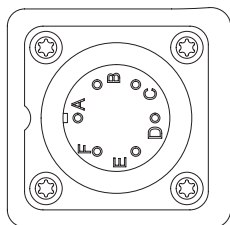

P200 125

*Pin assignments*

Pin	Controller Function	Notes
A	Power Input	
B	Power Ground	
C	CAN HI	
D	CAN LO	
E	Configuration Resistor	See <a href="#">Source addresses and resistor values</a> on page 15 for more information.
F	CAN Shield	There is a 0.68 uF capacitor and a 1 Ohm resistor in series to ground on this input for CAN shield termination.

Use care when wiring the mating connector.

---

## Sensor configuration

### Baud rate

The user can select baud rates of 125 Kbs, 250 Kbs, 500 Kbs, or 1,000 Kbs. The default is 250 Kbs. Change the baud rate by modifying parameter "CanBaudRate" with the PLUS+1® Service Tool. When the parameter is changed, a power cycle of the sensor is required before the requested baud rate takes effect.

### Identifier length

Both 11 and 29 bit identifiers are supported. The default is 29 bit. To change the identifier length, modify parameter UseExtendedID (0 = 11 bit, 1 = 29 bit) using the PLUS+1® Service Tool.

### Address claim

These sensors incorporate the SAE J1939 address claim procedure which helps avoid connecting a sensor to the CAN bus that has another device connected with the same source address. If the sensor cannot claim its requested source address, it will not transmit any CAN messages.

The J1939 name field is constructed as follows:

<b>Arbitrary Address Capable:</b>	0 – no
<b>Industry Group:</b>	3 – construction
<b>Vehicle System Instance:</b>	0
<b>Function</b>	143 – sonic sensor
<b>Function Instance:</b>	0
<b>ECU Instance:</b>	Based on SA selection 0-7
<b>Manufacturer Code:</b>	57 – Danfoss
<b>Identity Number:</b>	0

### Broadcast messages

To broadcast a message to all of the sensors connected on the CAN bus, use the global source address (0xFF). If only a single sensor on the CAN bus needs to be addressed, use the source address. See [Source addresses and resistor values](#) on page 15 for more information.

## Source Address (SA)

### Source addresses and resistor values

The sensors default Source Address (SA) is 191 (0xBF hex).

The sensor is capable of achieving 256 distinct SA, 31 of which may be selected through the use of the configuration pin. The pin can be connected directly to ground SA=160, left floating (SA=last programmed value) or connected to ground through one of 30 different resistor values. The table below defines the allowable SA and the required resistor value to achieve each address.

The SA is checked by the sensor's microprocessor each time it is powered up. In order to change the SA via the configuration pin, the sensor must be powered up with the configuration input pin connected to the appropriate value resistor. Any changes made to the SA while the sensor is powered are ignored until power has been cycled.

If, on power up, the SA configured by the resistor differ from the value currently stored in the sensor's non-volatile (NV) memory then the value in NV memory will be over written with the new SA, as long as the selected resistor value does not exceed 51,100 Ohms.

#### *SA and resistor values*

<b>SA</b>	<b>Resistor (Ohms)</b>	<b>SA</b>	<b>Resistor (Ohms)</b>
160 (0xA0)	0	176 (0xB0)	2430
161 (0xA1)	76.8	177 (0xB1)	2740
160 (0xA2)	162	178 (0xB2)	3160
163 (0xA3)	249	179 (0xB3)	3570
164 (0xA4)	340	180 (0xB4)	4120
165 (0xA5)	442	181 (0xB5)	4750
166 (0xA6)	562	182 (0xB6)	5490
167 (0xA7)	665	183 (0xB7)	6490
168 (0xA8)	806	184 (0xB8)	7680
169 (0xA9)	931	185 (0xB9)	9310
170 (0XAA)	1100	186 (0xBA)	11,500
171 (0xAB)	1270	187 (0xBB)	14,700
172 (0xAC)	1430	188 (0xBC)	19,600
173 (0xAD)	1650	189 (0xBD)	28,700
174 (0xAE)	1870	190 (0xBE)	51,100
175 (0xAF)	2150	Open	No Change

**Controller Area Network (CAN) Message Protocols**

The following paragraphs identify the CAN messages/commands available between the Control Application and the sensors.

**Mode**

This message is sent to the sensor to change the mode of the sensor from ground mode to string line mode or vice versa. The default mode of the sensor is Ground Mode.

*Mode CAN messages/commands*

<b>Transmission repetition rate:</b>	On Request
<b>Data length:</b>	2
<b>Extend Data Page:</b>	0
<b>Data Page:</b>	0
<b>PDU Format:</b>	255 (Proprietary B)
<b>PDU Specific:</b>	177
<b>Default Priority:</b>	3
<b>Parameter Group Number</b>	65457 (0xFFB3)
<b>XID:</b>	0x10
<b>CAN ID:</b>	0x0CFFB3 (SA)

*Sensor mode*

Start Position	Length	Parameter Description	SPN/Value
1	1 byte	XID	0x10 (Fixed)
2	1 byte	Sensor Mode	00 = Ground mode 01 = String Line Mode

**Survey**

Sets the reference height for the outlier filtering.

*Survey CAN messages/commands*

<b>Transmission repetition rate:</b>	On Request
<b>Data length:</b>	1
<b>Extend Data Page:</b>	0
<b>Data Page:</b>	0
<b>PDU Format:</b>	255 (Proprietary B)
<b>PDU Specific:</b>	177
<b>Default Priority:</b>	3
<b>Parameter Group Number</b>	65457 (0xFFB3)
<b>XID:</b>	0x11
<b>CAN ID:</b>	0x0CFFB3 (SA)



**Controller Area Network (CAN) Message Protocols**
*Sensor mode*

Start Position	Length	Parameter Description	SPN/Value
1	1 byte	XID	0x11 (Fixed)

**Offset**

This message raises or lowers the reference height for outlier filtering.

*Offset CAN messages/commands*

<b>Transmission repetition rate:</b>	On Request
<b>Data length:</b>	3
<b>Extend Data Page:</b>	0
<b>Data Page:</b>	0
<b>PDU Format:</b>	255 (Proprietary B)
<b>PDU Specific:</b>	177
<b>Default Priority:</b>	3
<b>Parameter Group Number</b>	65457 (0xFFB3)
<b>XID:</b>	0x12
<b>CAN ID:</b>	0x0CFFB3 (SA)

*Sensor mode*

Start Position	Length	Parameter Description	SPN/Value
1	1 byte	XID	0x12 (Fixed)
2	1 byte	Offset (LSB)	
3	1 byte	Offset (MSB)	

**LED**

This message sets the deviation LED pattern.

*LED CAN messages/commands*

<b>Transmission repetition rate:</b>	100 mSec
<b>Data length:</b>	2
<b>Extend Data Page:</b>	0
<b>Data Page:</b>	0
<b>PDU Format:</b>	255 (Proprietary B)
<b>PDU Specific:</b>	177
<b>Default Priority:</b>	3
<b>Parameter Group Number</b>	0xFFB3
<b>XID:</b>	0x13
<b>CAN ID:</b>	0x0CFFB3 (SA)

**Controller Area Network (CAN) Message Protocols**
*Sensor mode*

Start Position	Length	Parameter Description	SPN/Value
1	1 byte	XID	0x13 (fixed)
2.1	3 bits	Deviation LEDs Command	000 = all off 001 = Up 010 = On Grade 011 = UP & On Grade 100 = Down 101 = Up & Down 110 = Down & On Grade 111 = All On

**Data**

This message provides data and status information to the controller.

*DATA CAN messages/commands*

<b>Transmission Repetition Rate:</b>	Adjustable via parameter CanUpdateRate (Default = 10 mSec)
<b>Data Length:</b>	7
<b>Extended Data Page:</b>	0
<b>Data Page:</b>	0
<b>PDU Format:</b>	255 (Proprietary B)
<b>PDU Specific:</b>	177
<b>Default Priority:</b>	3
<b>Parameter Group Number:</b>	65458 (0xFFB3)
<b>XID:</b>	0x20
<b>CAN ID:</b>	0x0CFFB3 (SA)

*Sensor mode*

Start Position	Length	Parameter Description	SPN/Value
1	1 byte	XID	0x20
2.1	2 bits	Sensor Mode	00 = Elevation mode 01 = String line mode
3	1 byte	Elevation Data (LSB)	Range: 200 – 13000 Units: mm X 10
4	1 byte	Elevation Data (MSB)	
5	1 byte	String Distance (LSB)	Range: 0- 1500, Units: mm X 10
6	1 byte	String Distance(MSB)	
7	1 byte	String Position	Range: 0 – 11 0xFE = string not detected
8.1	2 bits	Sensor Status	00 = OK 01 = Stale ultrasonic data 10 = Out of operating range
8.3	2 bits	Bail status	00 = Bail Present 01 = Bail Not Present

---

**Technical Information    CMSS1000 CAN Multi-Sonic Sensor**

---

**Specifications**
**Electrical**

*CMSS1000 electrical specifications*

<b>Supply voltage</b>	9 to 36 Vdc
<b>Current consumption</b>	200 mA operational

**Mechanical**

*CMSS1000 mechanical specifications*

<b>Weight</b>	1.109 kg (2.446 lbs)
<b>Vibration</b>	IEC 60068-2-64
<b>Shock</b>	IEC 60068-2-27

**Ultrasonic performances**

*Ultrasonic performances*

<b>Ground sense range</b>	200 mm to 1000 mm (7.87 in to 39.37 in)
<b>Linearity</b>	± 1%
<b>Resolution</b>	0.1 mm (0.004 in)
<b>String line height range</b>	200 to 400 mm (7.87 in to 15.75 in)
<b>String line steer range</b>	150 mm (5.91 in)
<b>String line digital steer resolution</b>	15 mm (0.59 in)
<b>String line analog steer resolution</b>	3 mm (0.12 in)

**Environmental**

*CMSS1000 environmental specifications*

<b>Operating temperature</b>	-5° C to 70° C (23° F to 158° F)
<b>Storage temperature</b>	-40° C to 85° C (-40° F to 185° F)
<b>Ingress Protection rating (IP) with connector installed</b>	IP 67
<b>EMI/RFI rating</b>	100 V/m



**Products we offer:**

- Bent Axis Motors
- Closed Circuit Axial Piston Pumps and Motors
- Displays
- Electrohydraulic Power Steering
- Electrohydraulics
- Hydraulic Power Steering
- Integrated Systems
- Joysticks and Control Handles
- Microcontrollers and Software
- Open Circuit Axial Piston Pumps
- Orbital Motors
- PLUS+1® GUIDE
- Proportional Valves
- Sensors
- Steering
- Transit Mixer Drives

**Danfoss Power Solutions** is a global manufacturer and supplier of high-quality hydraulic and electronic components. We specialize in providing state-of-the-art technology and solutions that excel in the harsh operating conditions of the mobile off-highway market. Building on our extensive applications expertise, we work closely with our customers to ensure exceptional performance for a broad range of off-highway vehicles.

We help OEMs around the world speed up system development, reduce costs and bring vehicles to market faster.

Danfoss – Your Strongest Partner in Mobile Hydraulics.

**Go to [www.powersolutions.danfoss.com](http://www.powersolutions.danfoss.com) for further product information.**

Wherever off-highway vehicles are at work, so is Danfoss. We offer expert worldwide support for our customers, ensuring the best possible solutions for outstanding performance. And with an extensive network of Global Service Partners, we also provide comprehensive global service for all of our components.

Please contact the Danfoss Power Solution representative nearest you.

**Comatrol**

[www.comatrol.com](http://www.comatrol.com)

**Schwarzmueller-Inverter**

[www.schwarzmueller-inverter.com](http://www.schwarzmueller-inverter.com)

**Turolla**

[www.turollaocg.com](http://www.turollaocg.com)

**Hydro-Gear**

[www.hydro-gear.com](http://www.hydro-gear.com)

**Daikin-Sauer-Danfoss**

[www.daikin-sauer-danfoss.com](http://www.daikin-sauer-danfoss.com)

Local address:

**Danfoss Power Solutions (US) Company**  
2800 East 13th Street  
Ames, IA 50010, USA  
Phone: +1 515 239 6000

**Danfoss Power Solutions GmbH & Co. OHG**  
Krokamp 35  
D-24539 Neumünster, Germany  
Phone: +49 4321 871 0

**Danfoss Power Solutions ApS**  
Nordborgvej 81  
DK-6430 Nordborg, Denmark  
Phone: +45 7488 2222

**Danfoss Power Solutions Trading (Shanghai) Co., Ltd.**  
Building #22, No. 1000 Jin Hai Rd  
Jin Qiao, Pudong New District  
Shanghai, China 201206  
Phone: +86 21 3418 5200

Danfoss can accept no responsibility for possible errors in catalogues, brochures and other printed material. Danfoss reserves the right to alter its products without notice. This also applies to products already on order provided that such alterations can be made without changes being necessary in specifications already agreed. All trademarks in this material are property of the respective companies. Danfoss and the Danfoss logotype are trademarks of Danfoss A/S. All rights reserved.