



Technical Information

Sensors

Ultrasonic Controller/Sensor



Revision history*Table of revisions*

Date	Changed	Rev
November 2015	Maximum operating temperature	0401
September 2015	Converted to Danfoss layout	CA
October 2012	Removed controller 1035027 and 1035039	BA
March 2011	Added PLUS+1® Compliant	AB
February 2011	Replaces BLN-95-9078	AA

Contents
Overview

Description.....	4
1035019, 1035026, 1035029, and 1035036 controllers	4
1035024 controller	4
1035022, 1035028, 1035040, and 1035035 sensors	4
1035023 sensor.....	4
Features.....	4
Theory of operation.....	4
Related product.....	5

Technical data

Specifications.....	6
Connector pin definitions.....	6
Configurations.....	7
Dimensions.....	8

Operation

Operation setup.....	9
Manual functional test (for controllers only).....	9
Entering the manual test mode.....	9
Running the five manual tests.....	9
Manual test staging.....	9
EEPROM memory test.....	9
LED test.....	10
Potentiometer/LED test.....	10
Ultrasonic transceiver/LED/output driver test	10
Exiting manual test mode.....	10

System diagram

1035019, 1035026, 1035029, 1035030, 1035036.....	12
1035024, 1035025.....	12
1035022 open circuit, 1035028 closed circuit, 1035035, 1035040.....	13

Control diagram

1035019, 1035026.....	14
1035024, 1035025.....	14
1035022, 1035028, 1035035, 1035040.....	15

Overview

Description

The Ultrasonic Controller/Sensor has been developed to replace paddle or wand sensors. Both are non-contacting and therefore do not suffer from position or motion problems associated with standard mechanical sensors. These products are typically used to sense and control material flow. All units measure the distance to a target surface and produce a resulting output.

1035019, 1035026, 1035029, and 1035036 controllers

These controllers generate a signal, that varies proportionally with distance, to control an Electrical Displacement Control (EDC) for a hydrostatic transmission. Output from the controller is a pulse-width modulated, high-side switched valve drive, with a narrow proportional band. For ease of operation and mounting, the Ultrasonic Controller/Sensor's sensing distance range can be adjusted by turning an external knob mounted on the screed or by activating the dome switches on the devices cover plate.

1035024 controller

This controller drives a solenoid-controlled three-way valve with an output that is either on (full power) when the sensor is far from the target or off (zero power) when the target is near. It's height is adjustable with a knob on the screed or by activating the dome switches on the devices cover plate. The 1035025 is identical to the 5024, except the output is inverted.

1035022, 1035028, 1035040, and 1035035 sensors

These sensors produce an analog voltage output to drive an amplifier for controlling EDCs or bi-directional valves. The output varies proportionally throughout the entire operating range.

1035023 sensor

This sensor produces a PWM output proportional to the distance from the sensor to the target. An external amplifier controls the signal for controlling EDCs or bi-directional valves.

[See *Technical data* on page 6, *Connector pin definitions* on page 6, and *Configurations* on page 7.](#)

Features

- Non-contacting sensor
- Easy to mount
- Wide operating range
- Outputs to drive amplifiers or valves directly
- Adjustable setpoint
- On/Off or proportional controller; or ratiometric sensors

Theory of operation

The sensor element of the Ultrasonic Controller/Sensor generates an ultrasonic wave and receives a signal reflected back from the target surface. The time difference between emission and reception is proportional to distance. Sensor products output this distance signal as a voltage to an amplifier, where it is used to control a valve which varies the output speed of a hydrostatic transmission or position of a cylinder. See [1035022 open circuit](#), [1035028 closed circuit](#), [1035035](#), [1035040](#) on page 13.

The controller element of the Ultrasonic Controller/Sensor uses the same sensing head as the sensors, but provides a second control output. See [1035019](#), [1035026](#), [1035029](#), [1035030](#), [1035036](#) on page 12. The second output is pulse-width modulated (PWM). For example., a square wave varying from input voltage (high) to zero volts (low) whose percentage of time high per cycle varies with measured distance. The PWM output is configured to drive a valve directly. Once the controller is mounted, the desired

Overview

distance from the target may be varied through a dome switch located on the face plate of the device or through a remotely located potentiometer.

The 1035024 output is either on (full power) or off (zero power) for use with solenoid valves, see [1035024](#), [1035025](#) on page 12. When the sensor is 29 cm or greater from target, when set to minimum height adjustment, power is full on until the target is 25 cm or less away, at which point power is turned off. As with other ultrasonic controllers, the desired height is adjustable through dome switches or a remote pot.

As the output from the sensor/controller is varied, the hydrostatic drive varies material flow rate, resulting in the repositioning of the target. See [Control diagram](#) on page 14. As the target's position varies along the curves shown, the system will continually seek an equilibrium point. The 1035026 and 1035022 have proportional outputs that normally produce a continuous output, resulting in uniform speed control of the material flow mechanism. The 1035024 may produce intermittent stop and start of the material flow.

Typical applications for the Ultrasonic Controller/Sensor include: control of auger/conveyor drive speed on asphalt pavers, position control of strike-off gates on feed for asphalt or concrete pavers, position control of contour mechanisms and remote measurement and monitoring.

Related product
Accessories

KE14010 Feeder Control Amplifier	A printed circuit board, the KE14010 accepts a signal from an 1035022 or an MCX102A Potentiometer Sensor and actuates an Electrical Displacement Control (EDC) on a hydrostatic pump.
KW01028 Cable	Connects 1031097, 1035026 or 1035024 to machine bulkhead. MS connectors on both ends. Six socket on sensor end, five socket on machine end. Three conductors. Two-foot coil cord stretches to ten feet.
KW01009 Cable	Connects 1035026 or 1035024 to machine bulkhead. MS connectors on both ends. Six socket on both ends. Four conductors. Two-foot coil cord stretches to ten feet.
KW01029 Cable	Connects 1035022 to MCP112A1011. MS connectors on both ends. Six socket on sensor end, five socket on controller end. Three conductors. Two-foot coil cord stretches to ten feet. Plug compatible with MCX102A1004.
1031109 Cable	Connects 1035026 or 1035024 to machine bulkhead. MS connectors on both ends. Six socket on both ends. Four conductors. One and half-foot coil cord stretches to seven and half feet.
1035060 Remote Pot	Installs a potentiometer into the system.

Technical data
Specifications

Continuous operating temperature	14 to 185° F (-10 to 85° C)
Supply voltage	10 to 30 Vdc
Operating range	16 to 100 cm (6.3 to 39.4 in) varies by model.
Proportional valve drive output (1035026)	0–240 mA (12 Vdc into a 20 ohm load) 0–240 mA (24 Vdc into a 80 ohm load) high-side switched
Valve drive frequency (1035026)	1000 Hz, pulse-width modulated
ON/OFF valve drive output (1035024)	2.0 amp maximum into a 7 ohm minimum load High side switched
Control band (1035024)	4 cm (1.6 in)
Analog output (1035022)	1.5 Vdc at 6.3 inches (16 cm) 8.5 Vdc at 39.4 inches (100 cm)
Output impedance for analog output	1000 ohms, minimum

Connector pin definitions

Part number	A	B	C	D	E	F
1035019	BATT (+)	POT (-)	BATT (-)	PWM output	POT feedback	POT (+)
1035022	BATT (+)	DC output	BATT (-)	Not used	Not used	Not used
1035023	BATT (+)	BATT (-)	PWM output	BATT (-)	Not used	Not used
1035024	BATT (+)	POT (+)	BATT (-)	ON/OFF output	POT (-)	POT feedback
1035025	BATT (+)	POT (+)	BATT (-)	ON/OFF output	POT feedback	N/A
1035026	BATT (+)	POT (+)	BATT (-)	PWM output	POT (-)	POT feedback
1035028	BATT (+)	DC output	BATT (-)	Not used	Not used	Not used
1035029	BATT (+)	POT (+)	BATT (-)	PWM output	POT(-)	POT feedback
1035030	BATT (+)	POT (+)	BATT (-)	PWM output	POT (-)	POT feedback
1035035	BATT (+)	BATT (-)	DC output	Not used	Not used	N/A
1035036	BATT (+)	POT (-)	BATT (-)	PWM output	POT feedback	POT (+)
1035040	BATT (+)	DC output	BATT (-)	Not used	Not used	Not used

Technical Information Ultrasonic Controller/Sensor

Technical data

Configurations

Configurations

Part number	Sensing range	Control range	Control type	Output frequency	Output impedance	Loss-of-signal output	Remote pot
1035019	25 to 100 cm (9.8 to 39.4 in)	30 cm (11.8 in)	Proportional PWM High-side switching	200 Hz	180 Ohms	Augers ON	Yes
1035022	16 to 100 cm (6.3 to 39.4 in)	N/A	Ratiometric 1.5 to 8.5 Vdc	DC	1000 Ohms	Sends far target voltage (Augers ON)	No
1035023	20 to 91 cm (8.0 to 36.0 in)	N/A	Ratiometric Low-side switching	5000 Hz	250 Ohms	Augers ON	No
1035024	29 to 100 cm (11.5 to 39.5 in)	4 cm (1.6 in)	ON/OFF High-side switching	ON/OFF	0 Ohms	Augers ON	Yes
1035025	29 to 100 cm (11.5 to 39.5 in)	4 cm (1.6 in)	ON/OFF High-side switching (inverted)	ON/OFF	0 Ohms	Augers ON	No
1035026	29 to 100 cm (11.5 to 39.5 in)	20 cm (8.0 in)	Proportional PWM High-side switching	1000 Hz	25 Ohms (0 to 240 mA into 20 Ohms @ 12 Vdc, 80 Ohms @ 24 Vdc)	Augers ON	Yes
1035028	16 to 100 cm (6.3 to 39.4 in)	N/A	Ratiometric 0.5 to 4.5 Vdc	DC	1000 Ohms	Sends close target voltage (Augers OFF)	No
1035029	29 to 100 cm (11.5 to 39.5 in)	30 cm (11.8 in)	Proportional PWM High-side switching	1000 Hz	0 Ohms	Augers ON	Yes
1035030	29 to 100 cm (11.5 to 39.5 in)	20 cm (8.0 in)	Proportional PWM High-side switching	1000 Hz	0 Ohms	Augers ON	Yes
1035035	16 to 100 cm (6.3 to 39.4 in)	N/A	Ratiometric 1.5 to 8.5 Vdc	DC	1000 Ohms	Sends far target voltage (Augers ON)	No
1035036	20 to 100 cm (7.9 to 39.4 in)	25 cm (9.8 in)	Proportional PWM High-side switching	1000 Hz 12% Min. Duty Cycle (98% Max)	0 Ohms	Augers ON	Yes
1035040	16 to 100 cm (6.3 to 39.4 in)	N/A	Ratiometric 0.5 to 4.5 Vdc	DC	1000 Ohms	Sends far target voltage (Augers ON)	No

Technical data

Dimensions

mm [inches]

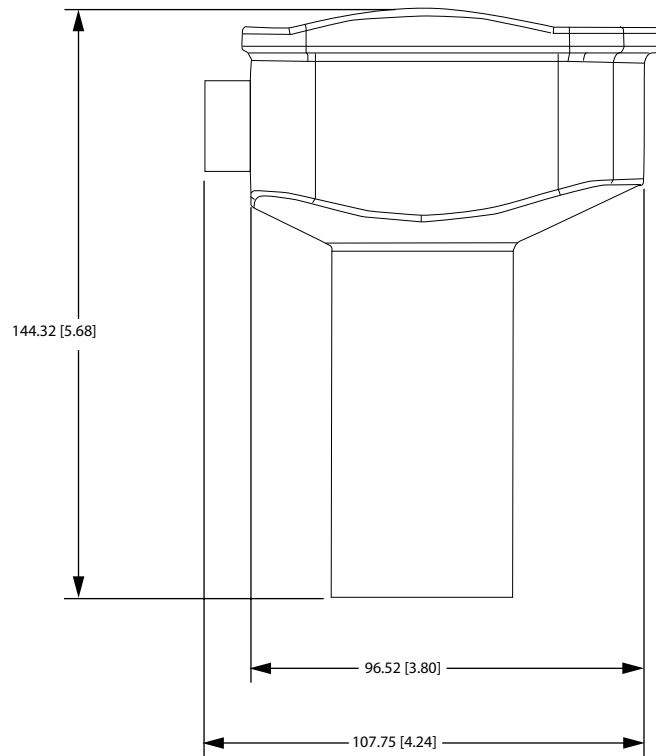
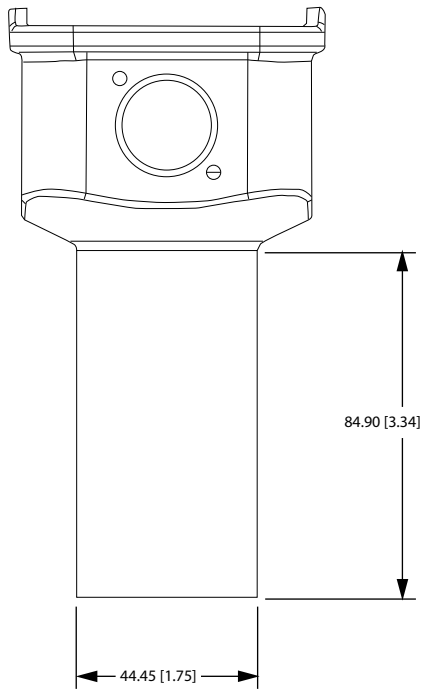
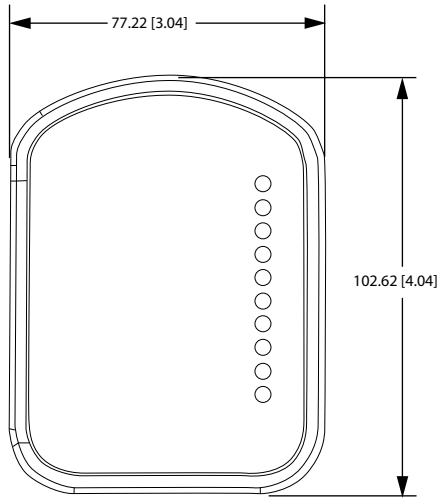

P200 056

Operation

Operation setup

- Pressing both dome switches simultaneously will set the high level of the material at the current height (establishes the set-point).
- Each push of a dome switch will change the material height approximately 0.5 cm (0.2 in).
- Pushing an increase or decrease button will move the fixed control-band within the working area.
- The PWM output is linear from 0% to 100% over the control band.
- If the target is lost or out-of-range, the device will scroll three LEDs up-and-down the LED bar-graph.
- For controllers, the LED bar-graph shows the set-point.
- For sensors, the LED bar-graph shows the material height.
- If a potentiometer is connected, it takes priority over the push-button switches and the push-button switches are deactivated. However, the push-button switches may still be used to enter the manual test.
- The latest set-point is saved in memory and will be stored if power is lost, and restored when power is turned back on.

Manual functional test (for controllers only)

The Ultrasonic Controller/Sensor has resident software to perform a manual test any time that the device operation is suspect.

Entering the manual test mode

1. To enter test mode, simultaneously press both membrane switch buttons (the increase-button and the decrease-button).
2. Continue holding the decrease-button (-), and release the increase-button (+).
3. Next, press the increase-button (+) ten additional times, while continuing to hold the decrease-button (-). When you have successfully completed this sequence, the transducer will stop transmitting the ultrasonic bursts, and the 10 LEDs, in the LED bar graph, will start a motion pattern that will start moving from the ends of the bar graph to the center of the bar graph. This is the signal that you have successfully entered the manual test mode.

While entering test mode, you have successfully exercised the membrane switches. The procedure for entering test mode, as well pressing the buttons to navigate within the manual test, serves as the membrane switch test.

Running the five manual tests

Manual test staging

1. Release both push-button switches.
You are now at the first step within the manual test. This is a staging step that can be recognized by the sequence of the flashing LED display.
2. Optional: To run the next test, press the decrease-button once.
3. Optional: To run a previous test, press the increase-button one time.

[Move to first test, last test, and back again by simultaneously pressing the increase-button and the decrease-button.](#)

EEPROM memory test

Press and release the decrease-button one time to run this test. The micro-controller will autonomously run the EEPROM test.

Operation

A successful completion of the test will result in all LEDs being on. If this test fails, then all LEDs will flash. If the LEDs flash, then one or more EEPROM locations are not capable of being reprogrammed.

LED Test will re-run by pressing and releasing increase-button.

LED test

1. Press and release the decrease-button one time to begin this next test.
Upon entry into this test, each LED will turn on, and then off again, in sequence.
2. The operator must verify that each individual LED in the bar-graph is functional. At no time should two LEDs be on simultaneously.

EEPROM memory test will re-run by pressing and releasing increase-button.

Potentiometer/LED test

Press and release the decrease-button one time to begin this test.

If the device is capable of being equipped with a potentiometer, then turning the pot will change the lights on the display. Depending on how the pot is connected, turning it fully one direction will result in all LEDs on. Turning it all the way in the other direction will result in all LEDs off, except for LED 0 (the least significant LED in the LED bar graph). LED 0 will always be on during this test.

As the LED bar-graph increases in length, the output from the PWM connection will increase, as well.

If no potentiometer is connected, then some arbitrary output will result along with some arbitrary LED display.

Caution

If the paver's augers are set in an automatic mode, then running this test will turn the augers.

Potentiometer/LED test will rerun by pressing and releasing the increase-button.

Ultrasonic transceiver/LED/output driver test

Press and release the decrease-button one time to enter this test.

The ultrasonic transducer will now activate and start transmitting signals and receiving the echoes.

The transducer must be pointed toward a suitable target to complete this test. Also, there must be an appropriate method of measuring the PWM output from the valve driver.

As the device is moved toward the target, the PWM output will either go to its minimum duty cycle or its maximum duty cycle, depending on the device configuration.

As the device is moved away from the target, the PWM output will go to its maximum duty cycle or its minimum duty cycle, depending on the device configuration. As the device moves away from the target, the LED display will go from all LEDs on to all LEDs off, except for the least significant LED in the array. LED 0 is always on during this test.

Caution

If the paver's augers are set in an automatic mode, then running this test will turn the augers.

Ultrasonic transceiver/LED/output driver test will re-run by pressing and releasing increase-button.

Exiting manual test mode

Pressing and releasing the decrease-button one time will allow the Ultrasonic Controller/Sensor to enter this test.

You will be able to recognize this test by observing the transducer and the LED bar graph. The transducer will stop transmitting and the 10 LEDs, in the LED bar graph, will start a motion pattern that will start moving from the ends of the bar graph to the center of the bar graph.

Operation

Exiting manual test mode will re-run by pressing and releasing increase-button.

Manual test mode is exited and normal operation resumes by simultaneously pressing the increase-button and the decrease-button.

System diagram

1035019, 1035026, 1035029, 1035030, 1035036

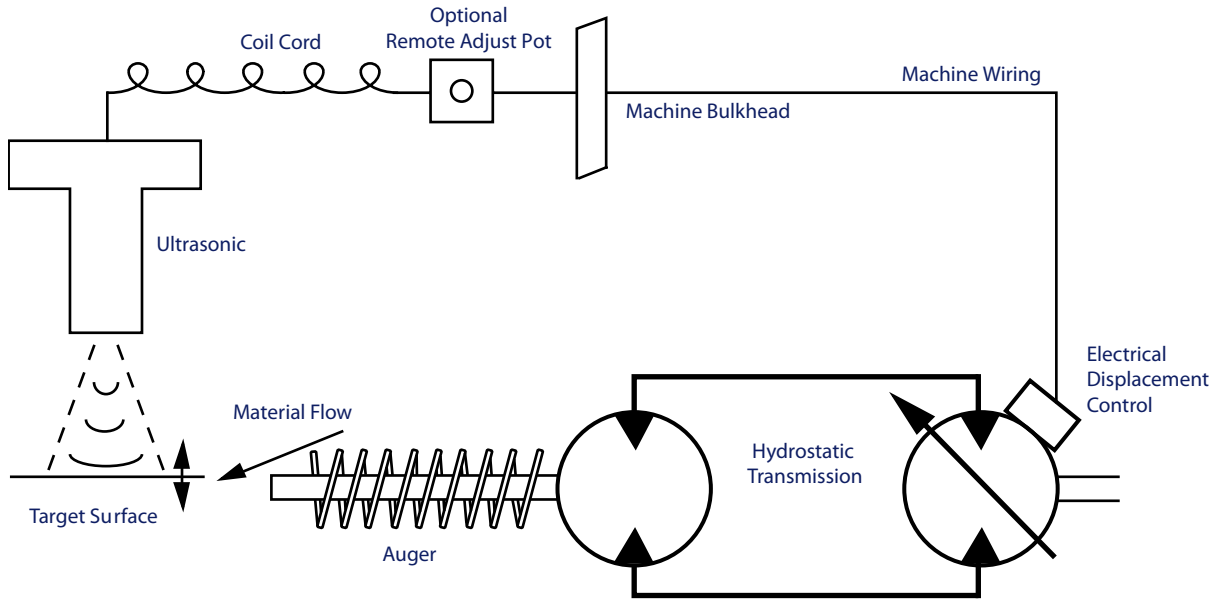

P200 058

1035024, 1035025

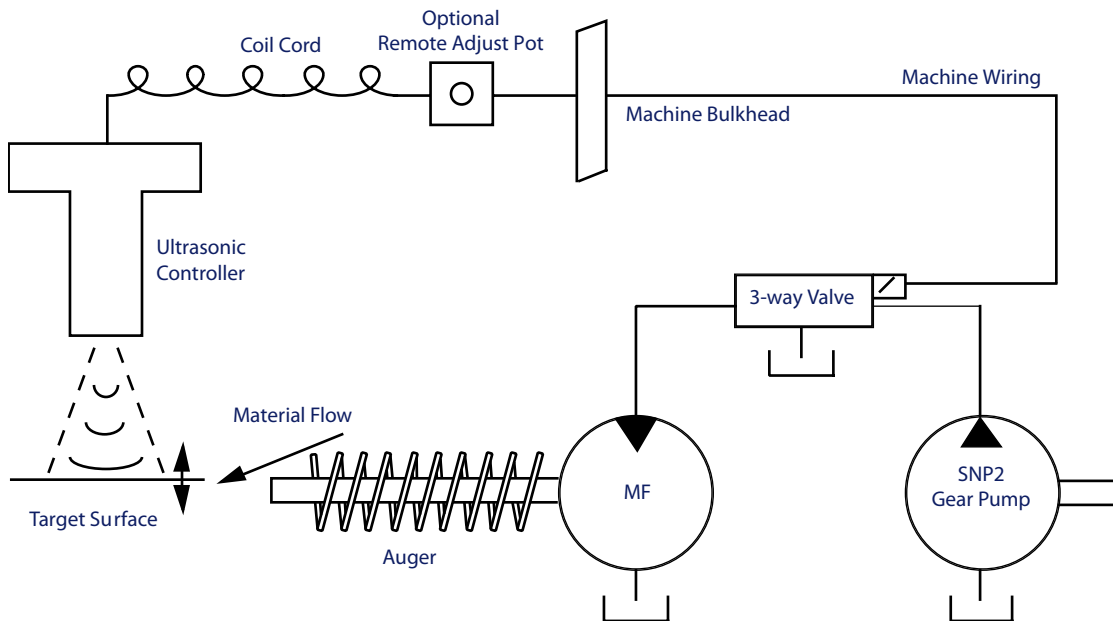

P200 059

Technical Information Ultrasonic Controller/Sensor

System diagram

1035022 open circuit, 1035028 closed circuit, 1035035, 1035040

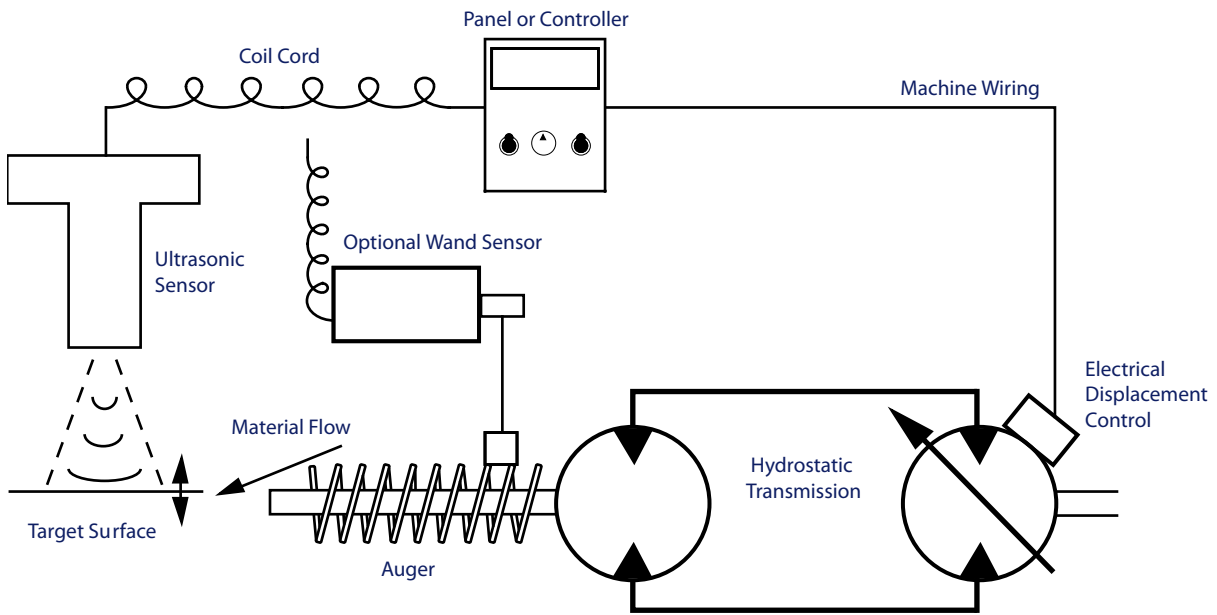

P200 060

Control diagram

1035019, 1035026

Control range of the pulse-width modulated output (pin D)

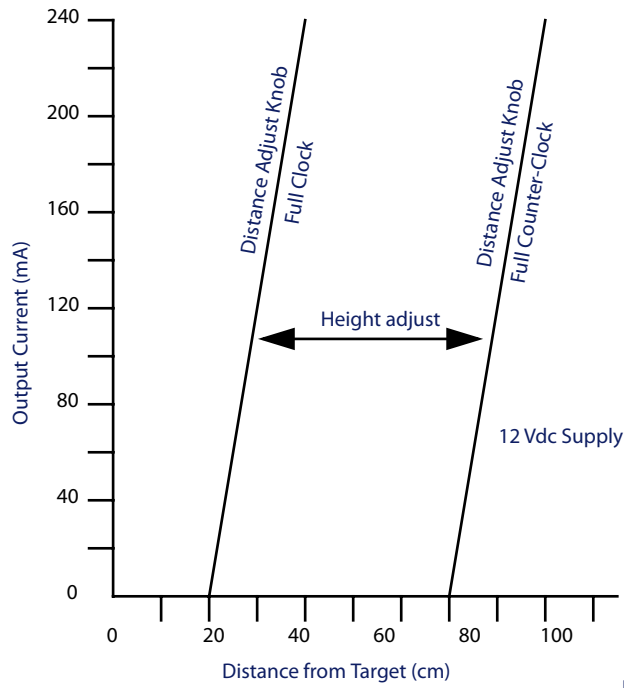

P200 061

1035024, 1035025

Control range of the ON/OFF output (pin D)

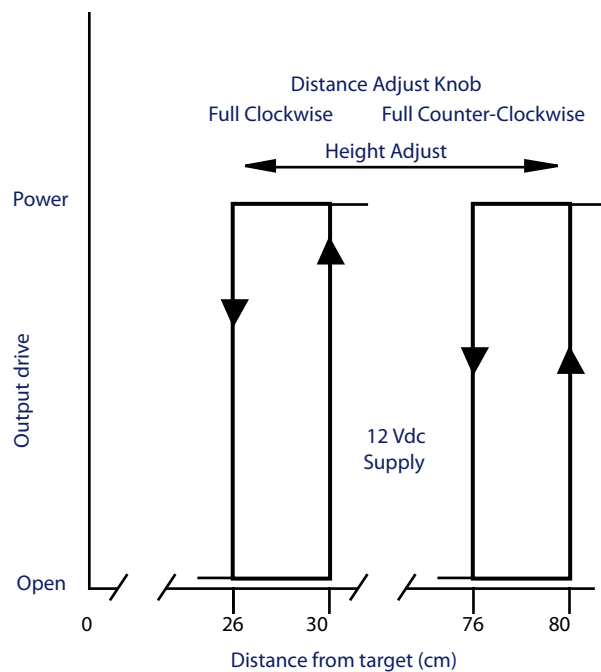

P200 062

Control diagram

1035022, 1035028, 1035035, 1035040

Control range of the analog output (pin B) for the 103522, 1035028 Ultrasonic Control/Sensor. Supply voltage is 12 or 24 Vdc and output impedances 1 k ohm.

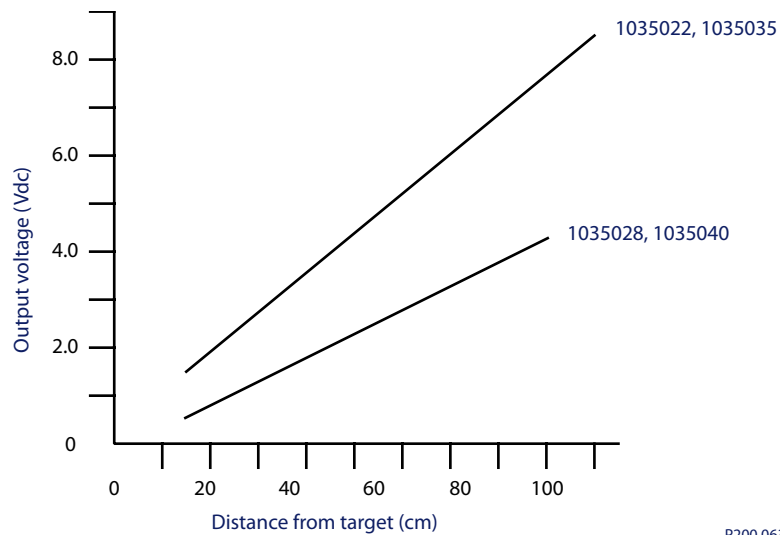

P200 063



Products we offer:

- Bent Axis Motors
- Closed Circuit Axial Piston Pumps and Motors
- Displays
- Electrohydraulic Power Steering
- Electrohydraulics
- Hydraulic Power Steering
- Integrated Systems
- Joysticks and Control Handles
- Microcontrollers and Software
- Open Circuit Axial Piston Pumps
- Orbital Motors
- PLUS+1® GUIDE
- Proportional Valves
- Sensors
- Steering
- Transit Mixer Drives

Danfoss Power Solutions is a global manufacturer and supplier of high-quality hydraulic and electronic components. We specialize in providing state-of-the-art technology and solutions that excel in the harsh operating conditions of the mobile off-highway market. Building on our extensive applications expertise, we work closely with our customers to ensure exceptional performance for a broad range of off-highway vehicles.

We help OEMs around the world speed up system development, reduce costs and bring vehicles to market faster.

Danfoss – Your Strongest Partner in Mobile Hydraulics.

Go to www.powersolutions.danfoss.com for further product information.

Wherever off-highway vehicles are at work, so is Danfoss. We offer expert worldwide support for our customers, ensuring the best possible solutions for outstanding performance. And with an extensive network of Global Service Partners, we also provide comprehensive global service for all of our components.

Please contact the Danfoss Power Solution representative nearest you.

Comatrol

www.comatrol.com

Schwarzmueller-Inverter

www.schwarzmueller-inverter.com

Turolla

www.turollaocg.com

Hydro-Gear

www.hydro-gear.com

Daikin-Sauer-Danfoss

www.daikin-sauer-danfoss.com

Local address:

Danfoss Power Solutions (US) Company
2800 East 13th Street
Ames, IA 50010, USA
Phone: +1 515 239 6000

Danfoss Power Solutions GmbH & Co. OHG
Krokamp 35
D-24539 Neumünster, Germany
Phone: +49 4321 871 0

Danfoss Power Solutions ApS
Nordborgvej 81
DK-6430 Nordborg, Denmark
Phone: +45 7488 2222

Danfoss Power Solutions Trading (Shanghai) Co., Ltd.
Building #22, No. 1000 Jin Hai Rd
Jin Qiao, Pudong New District
Shanghai, China 201206
Phone: +86 21 3418 5200

Danfoss can accept no responsibility for possible errors in catalogues, brochures and other printed material. Danfoss reserves the right to alter its products without notice. This also applies to products already on order provided that such alterations can be made without changes being necessary in specifications already agreed. All trademarks in this material are property of the respective companies. Danfoss and the Danfoss logotype are trademarks of Danfoss A/S. All rights reserved.