

ENGINEERING
TOMORROW

Danfoss

Selection Guide | VLT® OneGearDrive®

Powerful, efficient and hygienic

– all in only one frame size

Achieve up to

70%

variant reduction

using VLT® OneGearDrive®

together with

VLT® AutomationDrive FC 302

or VLT® Decentral Drive FCD 302

www.danfossdrives.com

VLT®

**Ultra Premium
efficiency**

class IE5 achieved with
a motor efficiency of

94.9%



Energy-efficient, flexible, reliable

VLT® OneGearDrive® comprises a high-efficiency permanent magnet (PM) motor coupled to an optimized bevel gearbox. As part of the Danfoss VLT® FlexConcept® the drive is an energy-efficient drive system that helps to optimize plant productivity and reduce energy costs. The VLT® FlexConcept® comprises the VLT® OneGearDrive®, combined with a VLT® Decentral Drive FCD 302 or VLT® AutomationDrive FC302.

Cost reductions with drive control

The VLT® OneGearDrive® features a PM motor, which is a three-phase synchronous non-salient motor. With an efficiency of 94.9% the motor achieves the IE5 Ultra Premium Efficiency Class defined in IEC TS 60034-30-2 while providing high torque in a compact motor frame.

With only one motor type and three available gear ratios, the motor concept covers all typical versions of conveyor drives commonly used in the food and beverage industry.

For conveyor drives in particular, this system dramatically projects whether the plant operator prefers a centralized or decentralized solution.

Optimized components – fewer variants

The VLT® OneGearDrive® uses optimized bevel gearing, which is more efficient than commonly used worm gears. As a whole, the system of gear motor and AC drive can reach an efficiency level of 89%, yielding energy savings of up to 40% compared with conventional systems.

The system components allow maximum flexibility with a minimum number of unit variations, such as motors, gear unit sizes or AC drives, all of which offer a uniform user interface concept and the same functionality. A reduced number of geared motor unit (GMU) variants across the plant also means smaller spare parts inventories and further cost reductions.

Flexible solutions – high efficiency

Electric drives play an important role in supporting food and beverage operations to optimize plant efficiency and reduce energy costs. The VLT® FlexConcept® takes this effort a crucial step further.

Savings in operations and maintenance

In the past, the various production areas: manufacturing, filling, packaging, palletizing, and storage required a variety of drive concepts. For example, dozens or even hundreds of drives were needed just to power the conveyors interconnecting the various production stages.

Previously, motors were not particularly efficient; there was a wide variety of transmissions and drives in use and maintenance costs were high. The consequences were, and still are, high energy costs and maintenance of large stocks of spare parts in order to minimize down-time. Since then, the evolution of variable speed drives has brought the drive/motor combination to a high peak of performance, capable of matching that of servo drives.

With the VLT® OneGearDrive® as part of the VLT® FlexConcept®, Danfoss has developed a flexible, standardized and efficient drive system that significantly reduces the number of drive variants, resulting in greatly reduced operating costs, substantial energy savings and carbon dioxide reductions.

Hygienic design required

Hygiene compliance rules are extremely demanding — especially in food and beverage production areas, but also in pharmaceutical and cosmetic manufacturing plants. That is why Danfoss has designed the VLT® OneGearDrive® to comply with the specifications and guidelines for the comprehensive, proactive protection of food from contamination with bacteria, fungi and yeasts during processing.

In the VLT® OneGearDrive® Danfoss has utilized years of experience in process and mechanical engineering, as well as knowledge in microbiology, to create a competitive, cost efficient solution that can easily be integrated into any production setup.

This is a clear advantage compared to upgrading existing process equipment designs to meet hygienic requirements, which is often both expensive and unsuccessful.

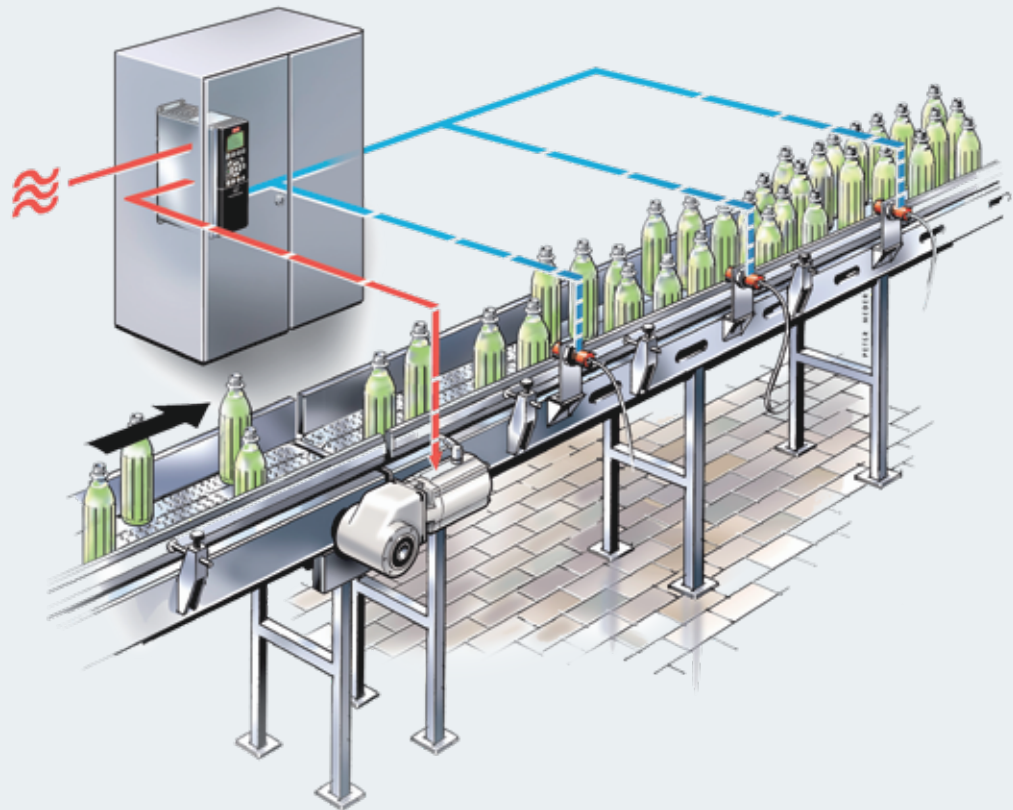
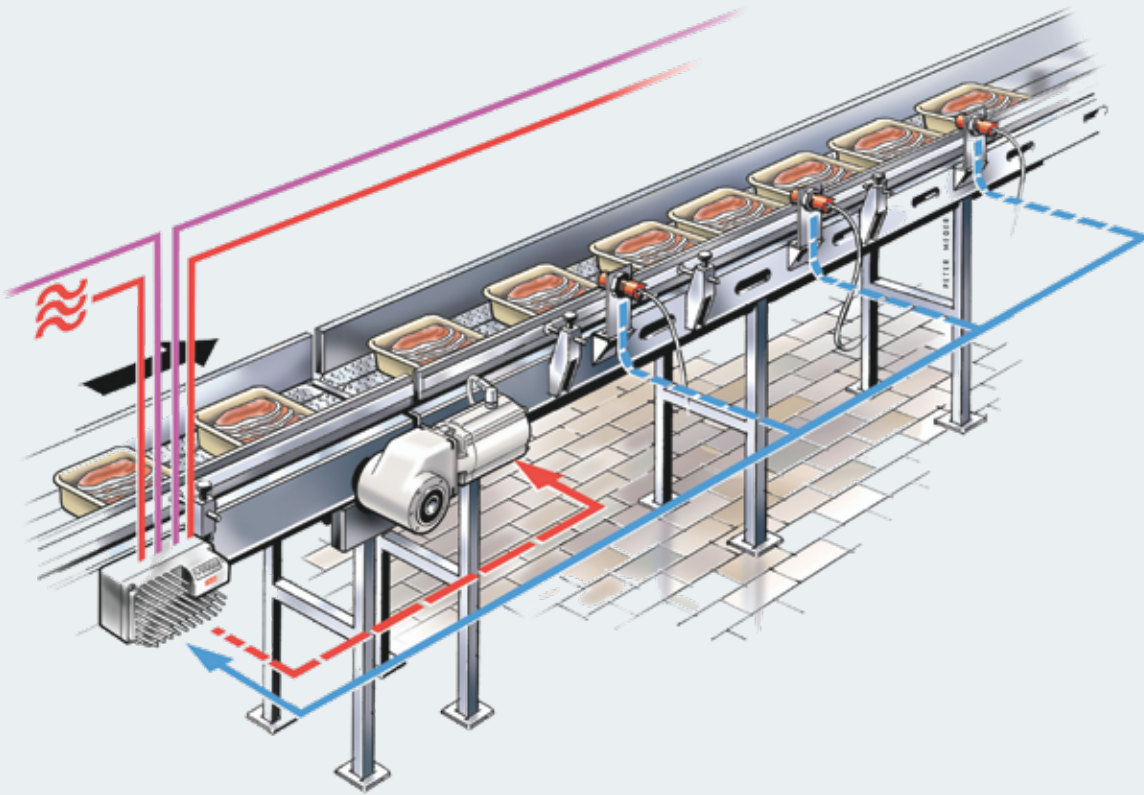

reddot design award

Awarded design

The design of the VLT® OneGearDrive® Hygienic also opens up totally new aesthetic and key stylistic elements in drive technology. The motor and gearbox together form a clean, simple entity and the product won the reddot design award 2010 for "high product quality, expressing innovation in form and function in an exemplary manner".

Use fewer variants – run a higher number of applications

VLT® OneGearDrive® – one gear size

Compared to traditional systems, the compact design of the VLT® OneGearDrive® makes it a strong choice that can provide benefits in transport and conveying systems as well as machines and equipment.

With only one motor type and three gear ratios available, the motor concept covers all typical conveyor drives. Furthermore, the restricted range of physical configurations of the VLT® OneGearDrive® simplifies spares stock and makes it more cost efficient, easing engineering and installation thanks to uniform mechanical dimensions.

Flexible plant design

In combination with the VLT® AutomationDrive FC 302 or the VLT® Decentral Drive FCD 302 the VLT® OneGearDrive® is equally suited to central and decentral installations, giving the plant designer complete flexibility from the outset.

A high breakaway torque is obtained and three gear ratios (5.92, 14.13, 31.13) are available. With a cable length of 500 ft (150m) shielded and 1000 ft (300m) unshielded between the drive and VLT® OneGearDrive®, all conditions for conveyor drives in the food & beverage applications are fulfilled.

Less expensive, fewer variants

Due to the PM motor there are lower losses, a smaller moment of inertia, a wide torque and speed range and high short-term overload capability, enabling high maximum torque over a wide speed range. This gear motor is a drive which, considered over its lifetime, is less expensive than conventional geared motor units (GMUs).

Long service intervals

The VLT® OneGearDrive® runs 35,000 operating hours in partial operation between oil changes (by using food grade oil). This means long service intervals, low maintenance costs and effort, and low operating cost.

Up to **40%**
energy savings

achieved, compared to conventional systems by using VLT® OneGearDrive® together with a VLT® AutomationDrive FC 302 or VLT® Decentral Drive FCD 302

Dry, wet and washdown aseptic areas

The VLT® OneGearDrive® comes in two versions, the VLT® OneGearDrive® Standard for use in dry and wet production areas while the VLT® OneGearDrive® Hygienic for use in aseptic areas heralds a new threshold in food hygiene and cleanability.



Hygienic design

Food safety

In food and beverage production areas where the product may come into direct contact with equipment and motors, the hygienic design of process equipment has a tremendous impact on diminishing the risks of contamination, which also means that the shelf life of products is improved. If the applied process equipment is of a poor hygienic design, it is difficult to clean in the event of micro-bacterial contamination.

New hygienic trends

EU regulations for the compliance of hygienic equipment to be used in the manufacturing of popular food and beverages are becoming increasingly tight. For example, in the beverage industry, still water, fruit juices and alcohol free beers are all highly reactive to external influences.

New packaging materials also raise the demands on the hygienic conditions. Plastic packaging for cosmetics, including PET bottles in the drinks industry, require new measures as they do not tolerate heat sterilization or cleaning that previously rendered glass containers aseptic.

Hygienic design

After years working with the food and beverage industry, Danfoss knows better than most the need for a robust, watertight construction that resists attack by acids or detergents, doesn't harbor bacteria and can be cleaned quickly and easily, shortening the maintenance window.

Completely smooth surface

Because these drives do not have fans, they do not suck in airborne germs and blast them back into the surrounding air. The drive units are also available with totally encapsulated brakes.

High degrees of protection

The VLT® OneGearDrive® Hygienic is resistant to detergents and disinfectants (pH 2 ..14). Danfoss supplies the VLT® OneGearDrive® Hygienic with high IP67 or IP69K ingress protection ratings as standard. A proven stainless steel plug-and-socket connector simplifies replacement during maintenance.

IPA certified

The VLT® OneGearDrive® Hygienic is certified as usable for clean rooms and aseptic filling by IPA (Fraunhofer institute) according to the dedicated "Air Cleanliness Classification" DIN EN ISO 14644-1.

The VLT® OneGearDrive® is designed to be integrated in the plant equipment and to withstand the same detergents and physical cleaning as the rest of the aseptic production equipment.

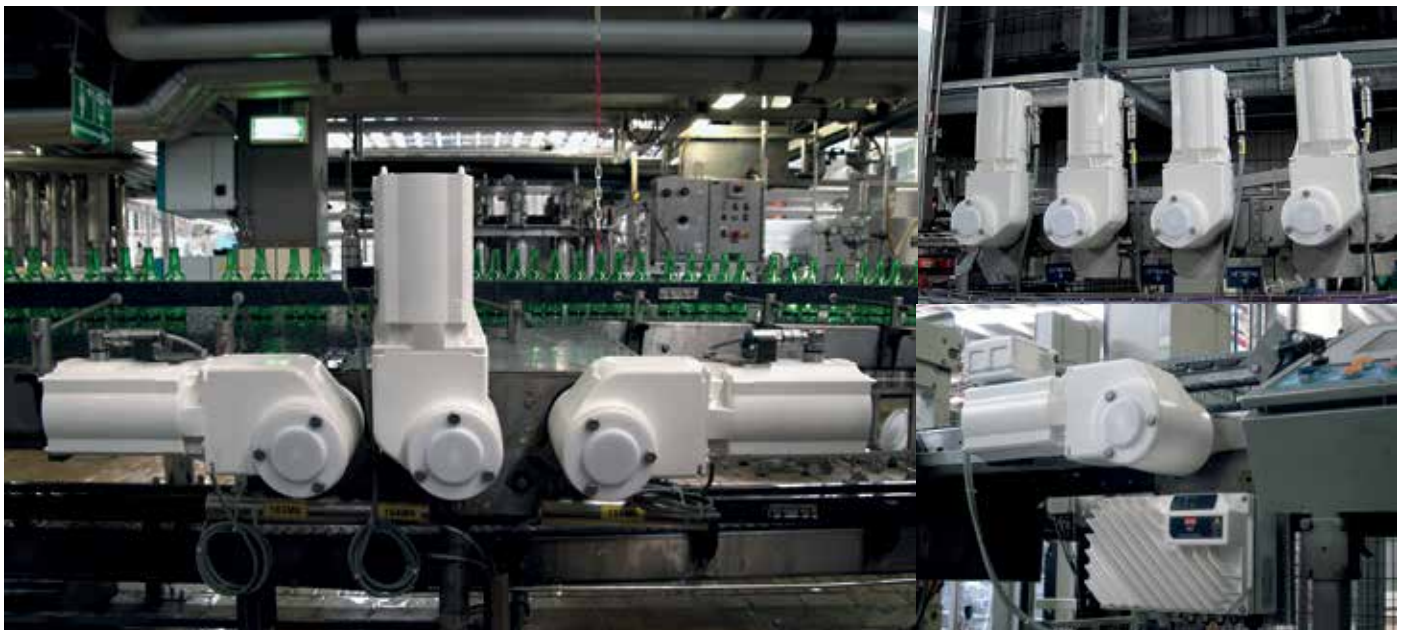

Two versions are all you need

The VLT® OneGearDrive® is available in two versions; the VLT® OneGearDrive® Standard for use in dry and wet production areas, and the VLT® OneGearDrive® Hygienic, for areas with high cleaning intensity including aseptic and cleanroom production areas.

- **Completely smooth surface
Fan-free motor, No cooling fins**
In both versions, the completely smooth, easy-to-clean surface free of cooling fins, prevents pockets of dirt from forming and allows detergents to drain off freely. The fan-free motor avoids the risk of airborne germs and dirt particles being drawn in and then expelled back into the surrounding air.
- **High degrees of protection**
IP67 and IP69K (OGD Hygienic) – allows unrestricted use in wash-down areas. IP67 (OGD Standard) – provides high protection in wash-down areas.
- **10 pole permanent magnet motor obtains a high torque**
High torque availability.
- **High efficiency bevel gear**
High break-away torque and uniquely compact design.
- = standard for both versions
- H = standard for VLT® OneGearDrive® Hygienic
- S = standard for VLT® OneGearDrive® Standard
- oH = optional for VLT® OneGearDrive® Hygienic
- oS = optional for VLT® OneGearDrive® Standard

- **Available hollow shaft diameters 30, 35 and 40 mm:**
Allow flexible adaptation to customer standards.
- H ■ **Motor connection with CleanConnect® stainless steel connectors**
Allows safe connection in wet areas, fast replacement, and high cleanability. The proven stainless steel plug-and-socket connectors simplify replacement during maintenance. This allows the replacement to be performed by a mechanical service technician alone, without the assistance of an electrician as in the past.
- S ■ **Motor connection via terminal box with CageClamp® technology**
Fast, reliable connection that lowers installation costs.

- H ■ oS ■ **Stainless steel hollow shaft**
AISI 316 Ti, corrosion resistant.
- H ■ S ■ **Food grade lubricants compliant with FDA and NSF requirements**
Enables reliable and direct use in product handling areas, with up to 35,000 hours between oil change.
- H ■ oS ■ **Certified aseptic coating**
Resistant to detergents and disinfectants (pH 2..14).



Two versions
The VLT® OneGearDrive® Standard with terminal box and to the left, the VLT® OneGearDrive® Hygienic with stainless steel connectors.

Speed/torque characteristics

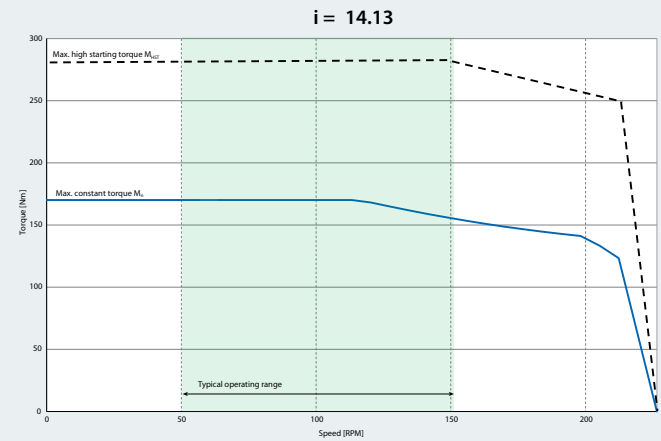
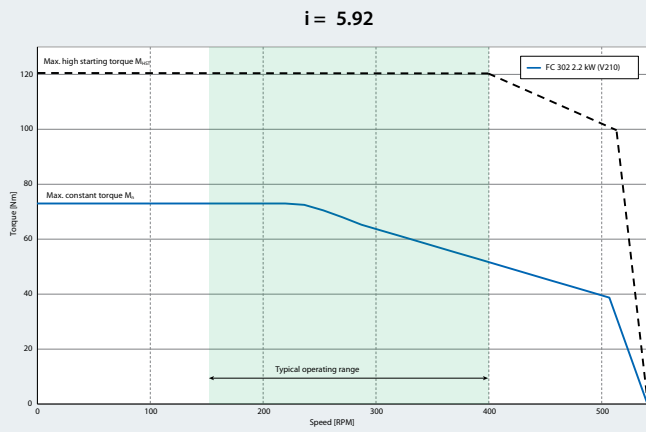

Nominal current:

5.5 A

Maximum AC drive power rating:

3 kW (nominal 2.2 kW)

Gear ratios:

i = 5.92

i = 14.13

i = 31.13

Example

Speed/torque characteristics in combination with VLT® AutomationDrive FC 302 or VLT® Decentral Drive FCD 302, for gear ratio i = 31.13

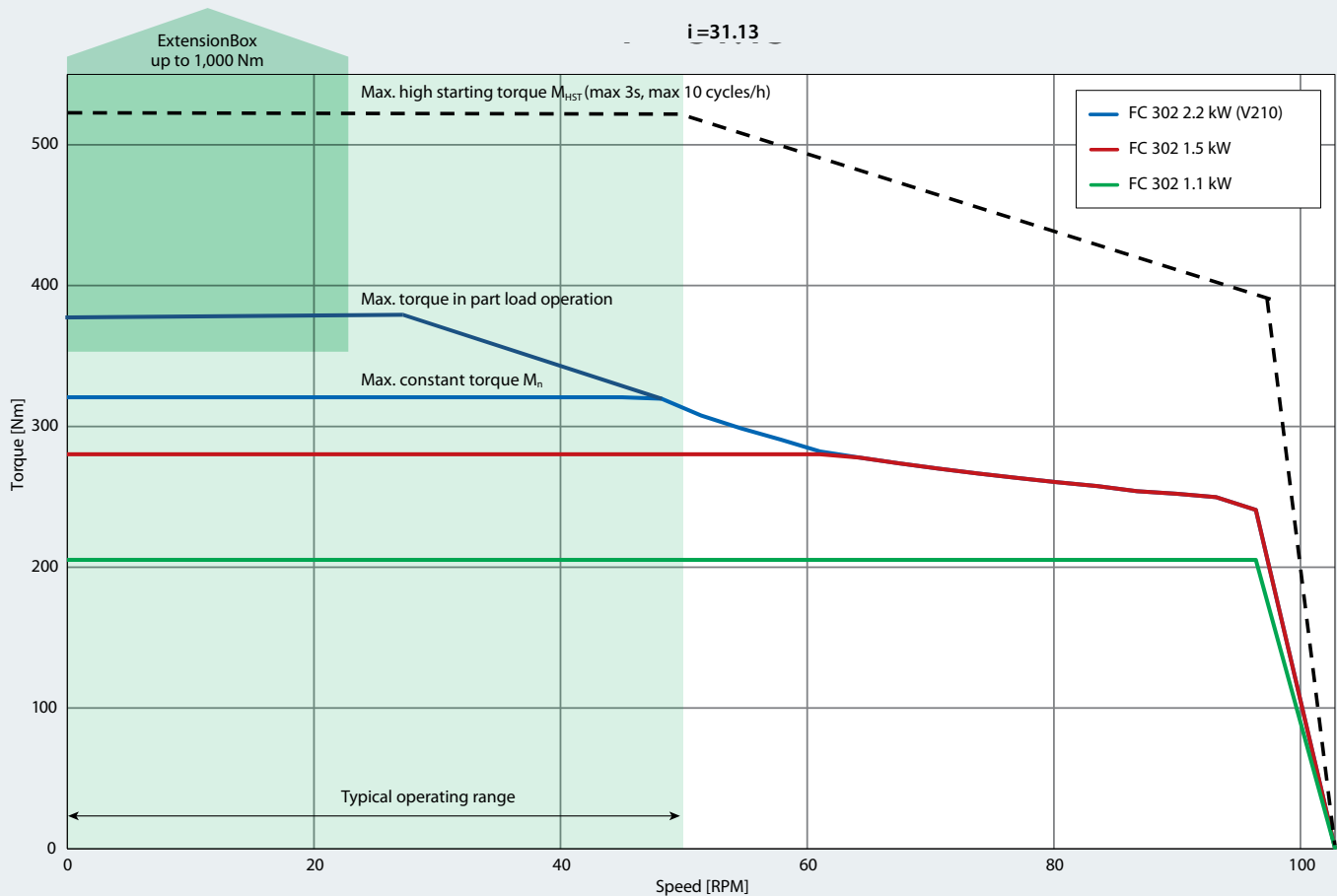

Installation positions

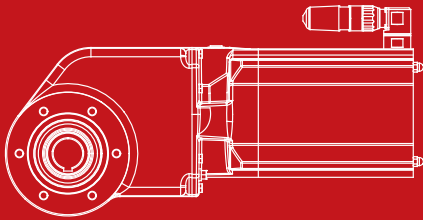

P1

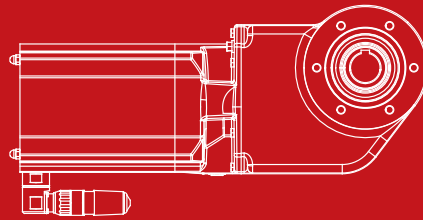

P2

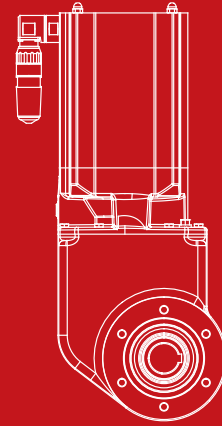

P3

Dimensions

VLT® OneGearDrive® Standard

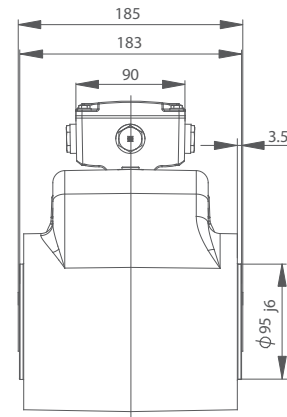
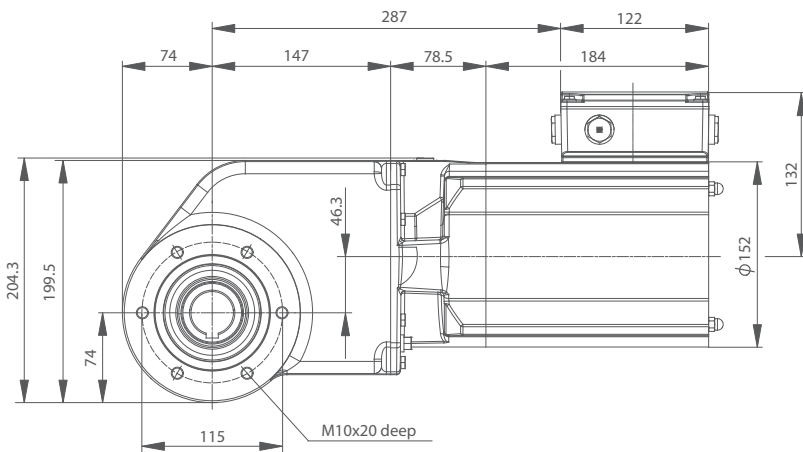

VLT® OneGearDrive® Hygienic

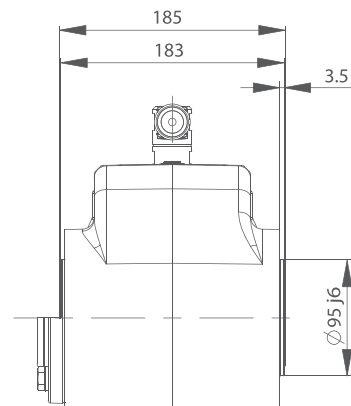
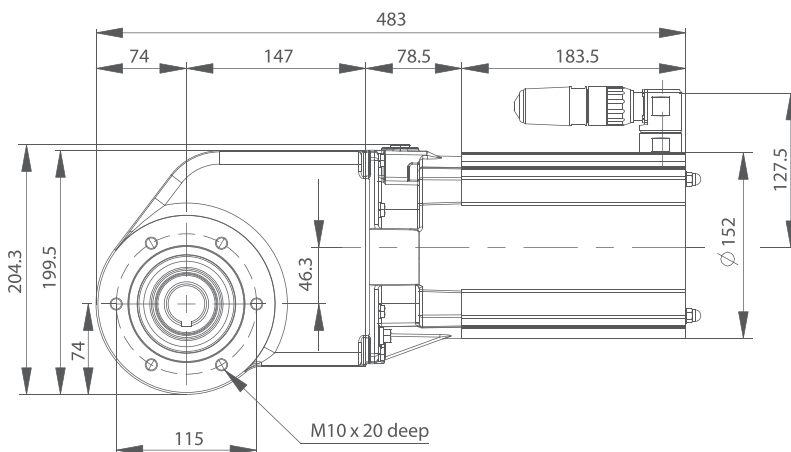

All measurements are in mm

Ordering type code

Position	1	2	3	4	5	6	7	8	9	10	11	12	13	14	15	16	17	18	19	20	21	22	23	24	25	26	27	28	29	30	31	32	33	34	35	36	37
Fixed	O	G	D		K	2						1				L	0	6	R	X			1				9	0	1	0	H	1					
Variants				S			0	5	K	9	2		3	0	1						T	B			P	2	S						B	X	X	X	X
				H			1	4	K	1	3		3	5	2						S	2			P	3	A					B	1	8	0	1	
							3	1	K	1	3		4	0							S	3									B	2	2	0			
													I	1							S	4															
													I	2																							
													I	3																							

[01-03]	Product group	OGD	VLT® OneGearDrive®
[04]	Product variant	S	Standard
		H	Hygienic
[05]	Gear type	K	Bevel gear
[06]	Size	2	V210
[07-11]	Gear ratio	05K92	5.92
		14K13	14.13
		31K13	31.13
[12]	Output shaft design	1	Hollow shaft
[13-14]	Output shaft size	30	30 mm
		35	35 mm
		40	40 mm
		I1	1 ¼ inch
		I2	1 7/16 inch
		I3	1 ½ inch

[15]	Output shaft material	1	Mild steel (OGD-S only)
		2	Stainless steel, AISI 316 Ti (standard for OGD-H, option for OGD-S)
[16-18]	Motor size	L06	Max 2.2 kW (V210)
[19-20]	Reserved	RX	Reserved X
[21-22]	Motor connection	TB	With terminal box (OGD-S only)
		S2	Motor with plug socket and motor connector, without cable (OGD-H only)
		S3	Motor with plug socket and motor connector, with 5 m cable (OGD-H only)
		S4	Motor with plug socket and motor connector, with 10 m cable (OGD-H only)
[23]	Connector position	1	Top

[24-25]	Installation position	P2	Horizontal, connections up or down (P1 = P2, see page 9)
		P3	Vertical, motor up (see page 9)
[26]	Surface coating	A	Aseptic (standard for OGD-H, option for OGD-S)
		S	Standard (OGD-S only)
[27-30]	RAL colour code	9010	Standard
[31-32]	Lubricants	H1	Food grade oil (standard in OGD-H and OGD-S)
[33-36]	Brake	BXXX	Without brake
		B180	180 V DC/ 400 V AC (option OGD-S)
		B220	220 V DC/ 480 V AC (option OGD-S)
[37]	CSA/UL	X	Without
		1	CSA/UL

NOTE: For availability of specific options and configurations please refer to drive configurator at <http://driveconfig.danfoss.com>

Accessories

VLT® OneGearDrive® Hygienic	Ordering number
Motor connector without cable	178H1613
Motor connector with 5 m cable	178H1630
Motor connector with 10 m cable	178H1631
Torque arm stainless steel	178H5006
VLT® OneGearDrive® Standard	Ordering number
Torque arm stainless steel	178H5006

Features and benefits

Feature	Benefit
High system efficiency, including drive	– Save money and energy – up to 40% power savings compared to conventional systems
High-efficiency permanent magnet three-phase synchronous 10-pole motor with bevel gear drive	– Ultra Premium Efficiency class IE5 with a motor efficiency of 94.9%. – Will comply to highest IES2 class with FC302
Available hollow shaft diameters: 30, 35, 40 mm and 3 impartial shaft sizes	– Flexible adaption to customer standards
Completely smooth enclosure leaves no crevices or dirt traps	– Easy to clean – Safe production
Motor connection with Danfoss CleanConnect® stainless steel circular connector	– Safe connection in wet areas – Fast installation and replacement – High cleanability
Motor and brake connections via terminal box with CageClamp® technology	– Fast, reliable connection – Lower installation cost
Aseptic coating	– Resistant to detergents and disinfectants (pH 2..14)
Antibac® antibacterial coating (on request)	– Reduced cleaning time and costs
Gearbox without breather vents and use of food grade lubricants compliant with FDA and NSF requirements	– Up to 35,000 operating hours in partial load between oil change
High degrees of protection: – IP67 and IP69K (OGD- H) – IP67 (OGD- S)	– Unrestricted use in washdown areas – High protection in washdown areas
Fan-free operation	– Less noise emission – No airborne germs and dirt particles are drawn into the motor and then expelled back into the surrounding air
Only 3 gearbox ratios in one common design	– Up to 70% reduction in variants reduces spare part stock
Compatible with all Danfoss drives, FC 302 and FCD 302 from 0.75 to 3 kW	– Free choice of central or decentral installation



VLT® OneGearDrive® Standard with brake



Specifications

VLT® OneGearDrive®	
Power rating	0.75-2.2 kW
Speed max.	3000 rpm
Frequency max.	250 Hz
Nominal current	5.5 A
Torque	2.35 Nm/A
Back-EMF	155 V/1000 rpm
Weight	Approx. 22 kg
Motor efficiency	IE5 Ultra Premium (94.9%)





A better tomorrow is **driven by drives**

Danfoss Drives is a world leader in variable speed control of electric motors.

We offer you unparalleled competitive edge through quality, application-optimized products and a comprehensive range of product lifecycle services.

You can rely on us to share your goals. Striving for the best possible performance in your applications is our focus. We achieve this by providing the innovative products and application know-how required to optimize efficiency, enhance usability, and reduce complexity.

From supplying individual drive components to planning and delivering complete drive systems; our experts are ready to support you all the way.

You will find it easy to do business with us. Online, and locally in more than 50 countries, our experts are never far away, reacting fast when you need them.

You gain the benefit of decades of experience, since 1968. Our low voltage

and medium voltage AC drives are used with all major motor brands and technologies in power sizes from small to large.

VACON® drives combine innovation and high durability for the sustainable industries of tomorrow.

For long lifetime, top performance, and full-throttle process throughput, equip your demanding process industries and marine applications with VACON® single or system drives.

- Marine and Offshore
- Oil and Gas
- Metals
- Mining and Minerals
- Pulp and Paper
- Energy

- Elevators and Escalators
- Chemical
- Other heavy-duty industries

VLT® drives play a key role in rapid urbanization through an uninterrupted cold chain, fresh food supply, building comfort, clean water and environmental protection.

Outmaneuvering other precision drives, they excel, with remarkable fit, functionality and diverse connectivity.

- Food and Beverage
- Water and Wastewater
- HVAC
- Refrigeration
- Material Handling
- Textile

VLT® | VAGON®

Tel. +1 (888) DANFOSS | www.danfossdrives.com | E-mail: salesinformation@danfoss.com

Danfoss Drives: Houston, TX • Loves Park, IL • Milwaukee, WI • Raleigh, NC • Stony Creek, ON

Danfoss can accept no responsibility for possible errors in catalogues, brochures and other printed material. Danfoss reserves the right to alter its products without notice. This also applies to products already on order provided that such alterations can be made without consequential changes being necessary in specifications already agreed. All trademarks in this material are property of the respective companies. Danfoss and the Danfoss logotype are trademarks of Danfoss A/S. All rights reserved.