

Installation Instructions

Fan Assembly

1.1.1 Items Supplied

- Fan assembly

1.1.2 Safety Instructions

For important information about safety precautions for installation, refer to *VLT® DriveMotor FCP 106 and FCM 106 Operating Instructions*

⚠ WARNING

DISCHARGE TIME

The frequency converter contains DC-link capacitors, which can remain charged even when the frequency converter is not powered. Failure to wait the specified time after power has been removed before performing service or repair work, could result in death or serious injury.

1. Stop motor.
2. Disconnect AC mains, permanent magnet type motors, and remote DC-link power supplies, including battery back-ups, UPS, and DC-link connections to other frequency converters.
3. Wait for the capacitors to discharge fully, before performing any service or repair work. The duration of waiting time is specified in *Table 1.1*.

Voltage [V]	Power Range ¹⁾ [kW]	Minimum waiting time (min)
3x400	0.55–7.5	4
High voltage can be present even when the warning LED indicator lights are off.		

Table 1.1 Discharge Time

¹⁾ Power ratings relate to NO, see *VLT® DriveMotor FCP 106 and FCM 106 Operating Instructions*.

1.1.3 Remove Defect Fan Assembly

Remove the cover of the frequency converter, as shown in *Illustration 1.1*.

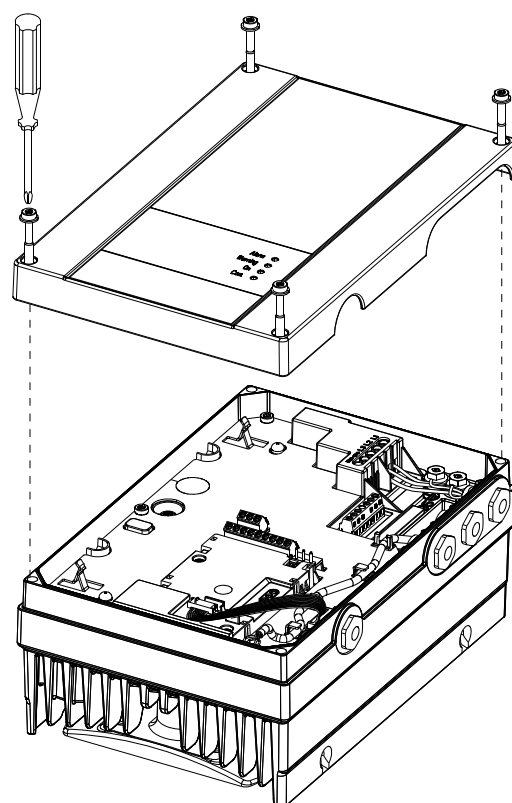
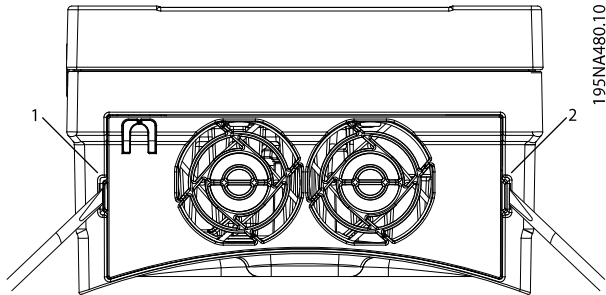

Illustration 1.1 Remove Front Cover

1. Unplug fan cable plug connection, see *Illustration 1.4*.
2. Release the fan cable.
3. Release the snaps on each side of the fan assembly, using a screwdriver. See *Illustration 1.2*.
4. Lift out the fan assembly.



195NA480.10

1, 2	Snaps
------	-------

Illustration 1.2 Release the Fan Assembly

1.1.4 Install New Fan Assembly

1. Insert the fan cable through the cable entry point, see *Illustration 1.3*.
2. Insert the fan assembly. Press carefully in place until the snaps make a click sound.
3. Plug in the fan cable as shown in *Illustration 1.4*. Use the cable snaps to hold the cable in place.

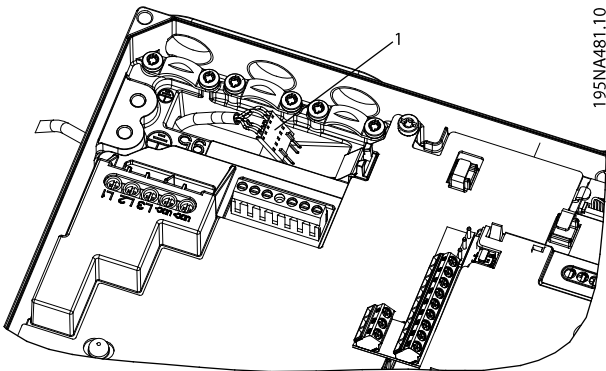

195NA481.10

1	Fan cable with plug
---	---------------------

Illustration 1.3 Fan Cable Entry Point

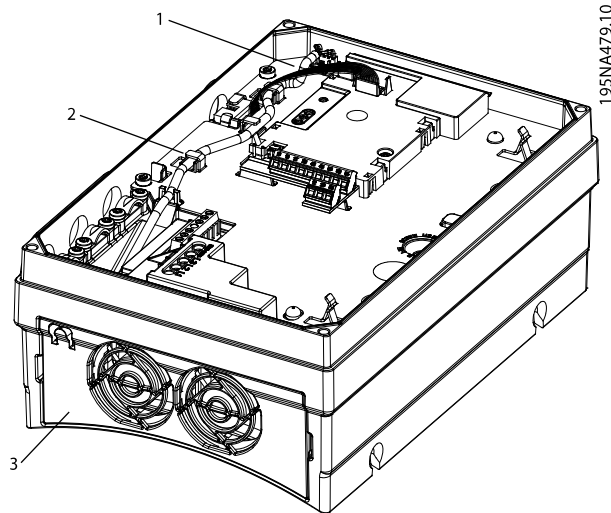

195NA479.10

1	Fan cable plug connection point
2	Cable snap
3	Fan assembly

Illustration 1.4 Plug in the Fan Cable

1.1.5 Replace Cover

1. When procedure is complete, reassemble frequency converter cover in the reverse order.
2. Fasten the 4 screws using a Torx 20 screwdriver, tightening torque 3-3.5 Nm.

