

**Assembly Instruction for VLT® Weather Shield - Outdoor Drives Option**

The weather shield is intended to provide additional protection of outdoor rated drives, when there is a risk of snow collecting on the top of the drive or excessive rain, which could sub-cool the drive, leading to internal condensation. The weather shield is made of corrosion resistant stainless steel AISI316 and is also suitable for installation in coastal areas and marine environments.

The weather shield is also to be used if there is a risk of direct sunlight on the display, since heat generated by the sun radiation might damage the LCD as well as limit the maximum ambient temperature.

**NOTE:**

**The weather shield should only be used together with outdoor rated drives and will not provide sufficient protection for outdoor installation of drives not designed for this purpose.**

Weather shield selection:

Frame Size	Ordering Number
A4, A5, B1, B2	130B4598
C1, C2	130B4597

**Assembly procedure**

1. Drill holes according to the measurements of the frequency converter.
2. Mount the frequency converter.

**NOTE**

**Allow a space of 10 mm between the unit and the wall for insertion of the bracket**

3. Slide the bracket between the wall and the frequency converter and tighten the screws.

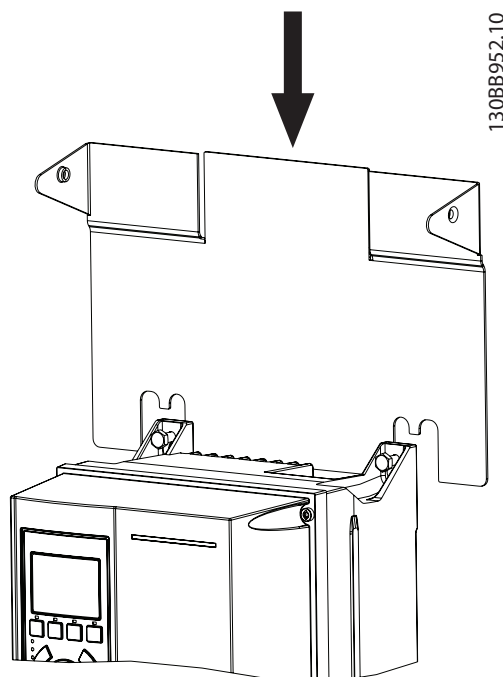

4. Slide the shield onto the bracket.

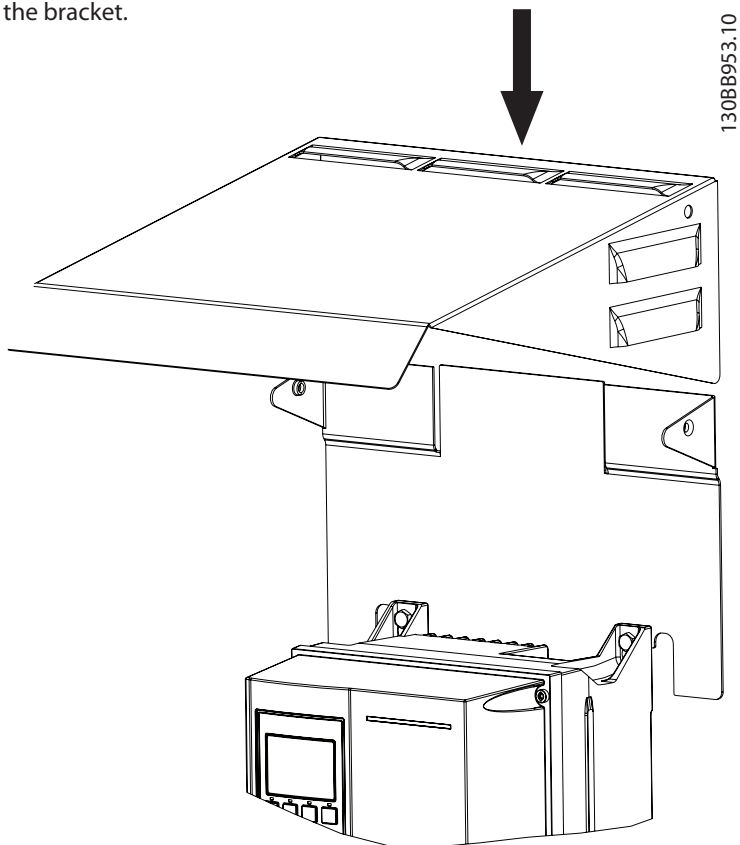

5. Fasten the shield to the bracket with two screws (max. tightening torque 5 Nm).

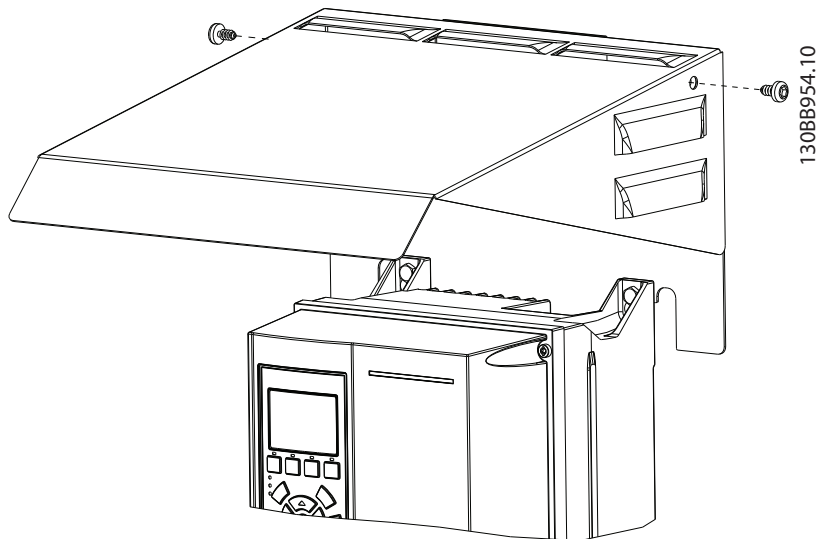

Danfoss can accept no responsibility for possible errors in catalogues, brochures and other printed material. Danfoss reserves the right to alter its products without notice. This also applies to products already on order provided that such alterations can be made without subsequential changes being necessary in specifications already agreed. All trademarks in this material are property of the respective companies. Danfoss and the Danfoss logotype are trademarks of Danfoss A/S. All rights reserved.

