

Installation Instructions

In-bottom/Out-top Cooling Kit for E3h Drives

VLT[®] FC Series FC 102, FC 103, FC 202, and FC 302

1.1 Description

The in-bottom/out-top cooling kit fits the following E3h drives. It is compatible with drives mounted in Rittal TS8 cabinets with widths of 600 mm (24 in) or 800 mm (32 in).

- VLT[®] HVAC Drive FC 102
- VLT[®] Refrigeration Drive FC 103
- VLT[®] AQUA Drive FC 202
- VLT[®] Automation Drive FC 302

When the kit is installed, air flows into the bottom duct and out through the top duct of the drive. See *Illustration 1.1*.

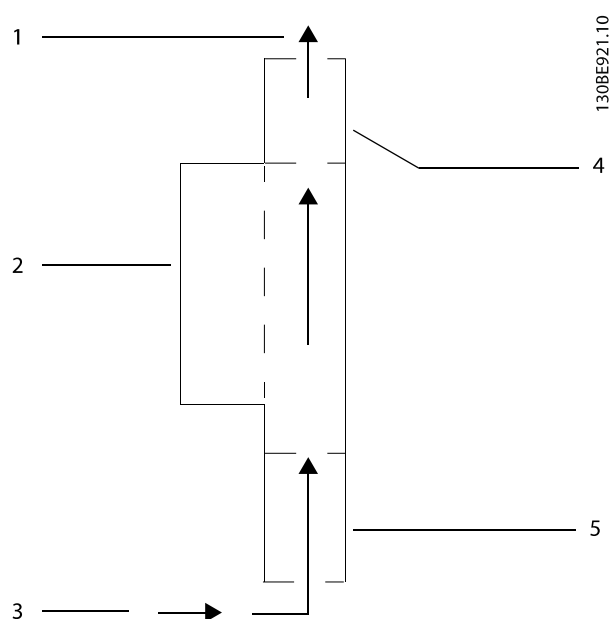

1	Back-channel airflow (exhaust)
2	Drive
3	Back-channel airflow (intake)
4	Top duct assembly
5	Bottom duct assembly

Illustration 1.1 Direction of Airflow with Kit Installed

1.1.1 Kit Part Numbers

Use these instructions with the following cooling kit.

Kit number	Kit description
176F6606	In-bottom/out-top cooling kit for E3h drives in 600 mm (24 in) enclosures
176F6607	In-bottom/out-top cooling kit for E3h drives in 800 mm (32 in) enclosures

Table 1.1 Part Numbers for Cooling Kits

1.1.2 Items Supplied

The in-bottom/out-top cooling kit contains the following items. Refer to *Illustration 1.2*.

Item	Quantity
Bottom bracket	1
Bottom gasket	1
Enclosure base plate	1
Bottom duct assembly	1
Top duct assembly	1
M5x18 screws	4
M5x14 screws	10
M5 hex nut	12

Table 1.2 Items Supplied in Cooling Kit

1.2 Safety Instructions

Only qualified, Danfoss authorized personnel are allowed to install the parts described in these installation instructions. Handling of the drive and its parts must be done in accordance with the corresponding *operating guide*.

⚠WARNING

ELECTRICAL SHOCK HAZARD

VLT® FC series drives contain dangerous voltages when connected to mains voltage. Improper installation, and installing or servicing with power connected, can cause death, serious injury, or equipment failure.

To avoid death, serious injury, or equipment failure:

- Only use qualified electricians for the installation.
- Disconnect the drive from all power sources before installation or service.
- Treat the drive as live whenever the mains voltage is connected.
- Follow the guidelines in these instructions and local electrical safety codes.

⚠WARNING

DISCHARGE TIME

The drive contains DC-link capacitors, which can remain charged even when the drive is not powered. High voltage can be present even when the warning LED indicator lights are off. Failure to wait 40 minutes after power has been removed before performing service or repair work can result in death or serious injury.

- Stop the motor.
- Disconnect AC mains and remote DC-link power supplies, including battery back-ups, UPS, and DC-link connections to other drives.
- Disconnect or lock PM motor.
- Wait 40 minutes for capacitors to discharge fully.
- Before performing any service or repair work, use an appropriate voltage measuring device to make sure that the capacitors are fully discharged.

1.3 Installation Instructions

NOTICE

APPLYING GASKETS

This kit contains gaskets to ensure a proper seal between metal parts. Before adhering a gasket to a part, check that the part matches the gasket and that no holes are covered.

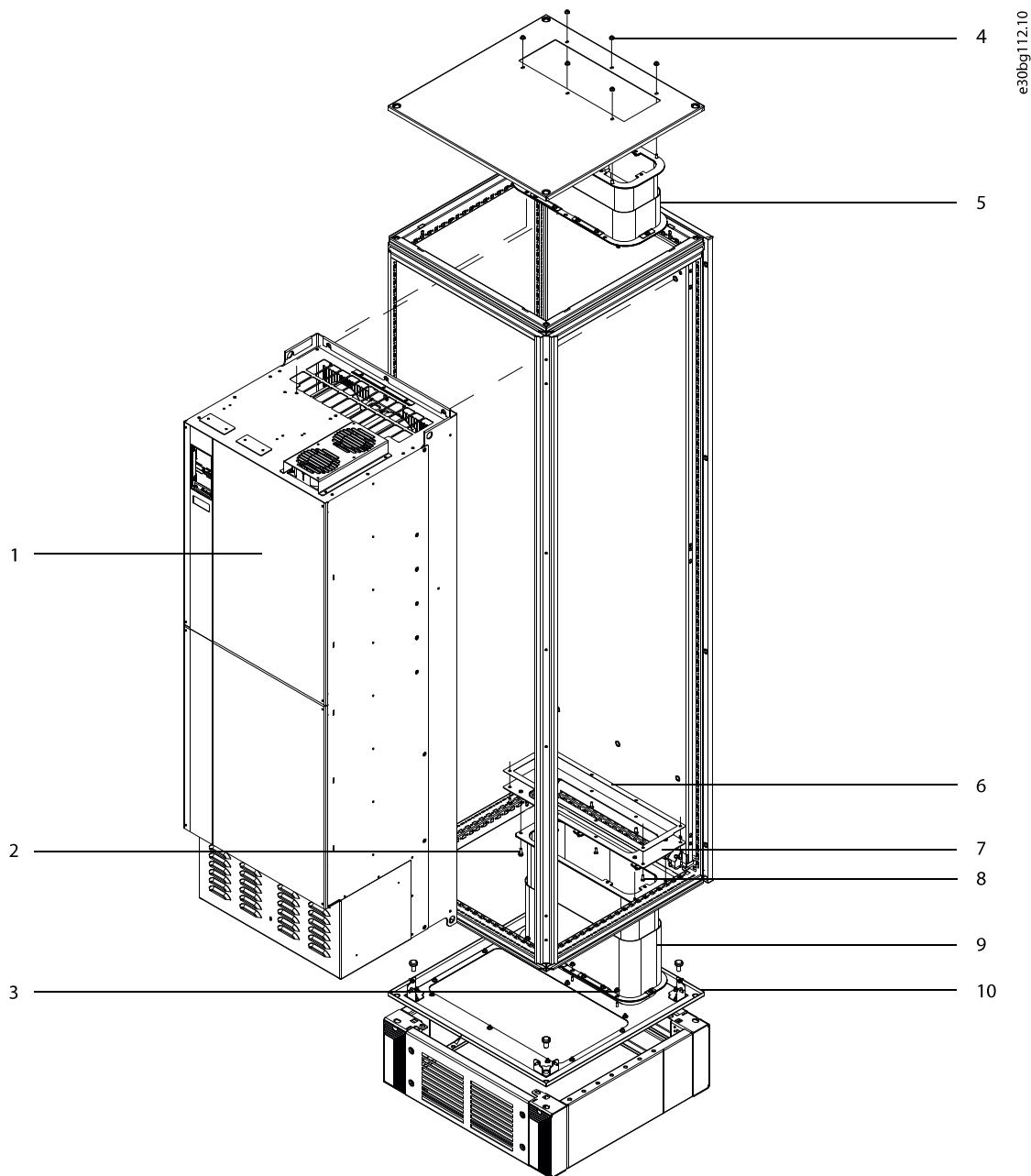

1	Drive	6	Bottom gasket
2	M5x18 screw	7	Bottom bracket
3	M5 hex nut	8	M5x14 screw
4	M5 hex nut	9	Bottom duct assembly
5	Top duct assembly	10	Base plate

Illustration 1.2 Overview of In-bottom/Out-top Cooling Kit

1.3.1 Creating Mounting Holes in the Mounting Plate

To create mounting holes in the drive mounting plate, use the following steps. Refer to *Illustration 1.3* for 600 mm (24 in) enclosures, and to *Illustration 1.4* for 800 mm (32 in) enclosures.

1. Drill 6 mounting holes in the back of the drive using the dimensions in *Illustration 1.3* or *Illustration 1.4*. The holes must match the holes in the drive.
2. Insert 6 M10 pem self-clinching nuts (not supplied) in the mounting holes.

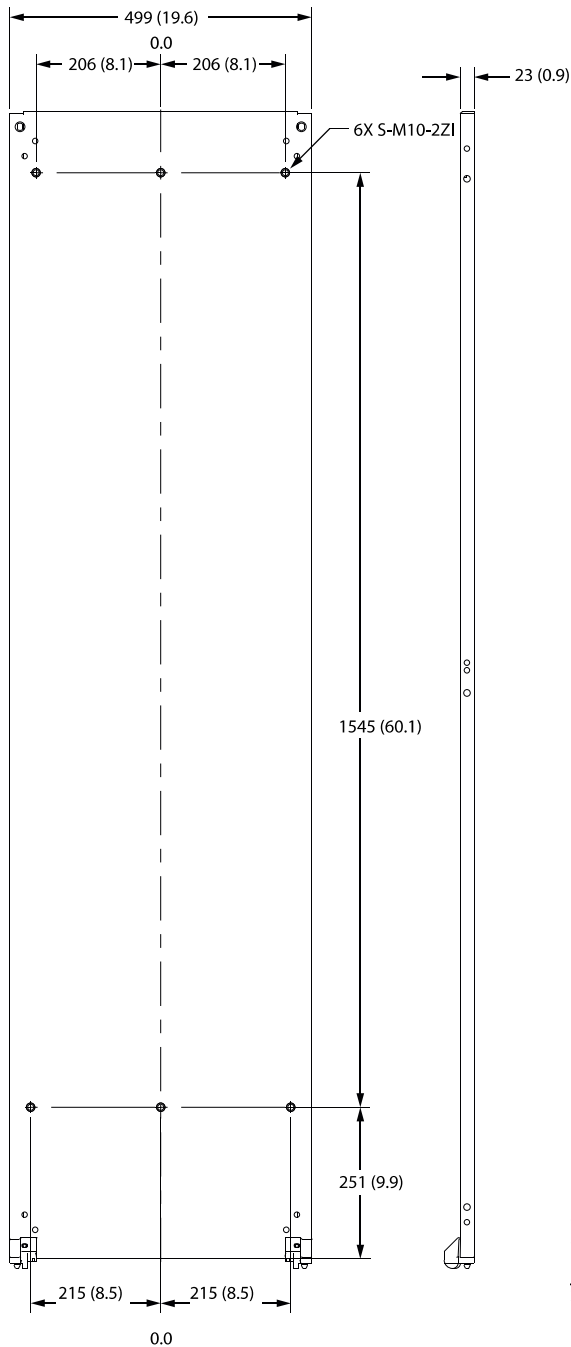

Illustration 1.3 Mounting Plate in 600 mm (24 in) Enclosure

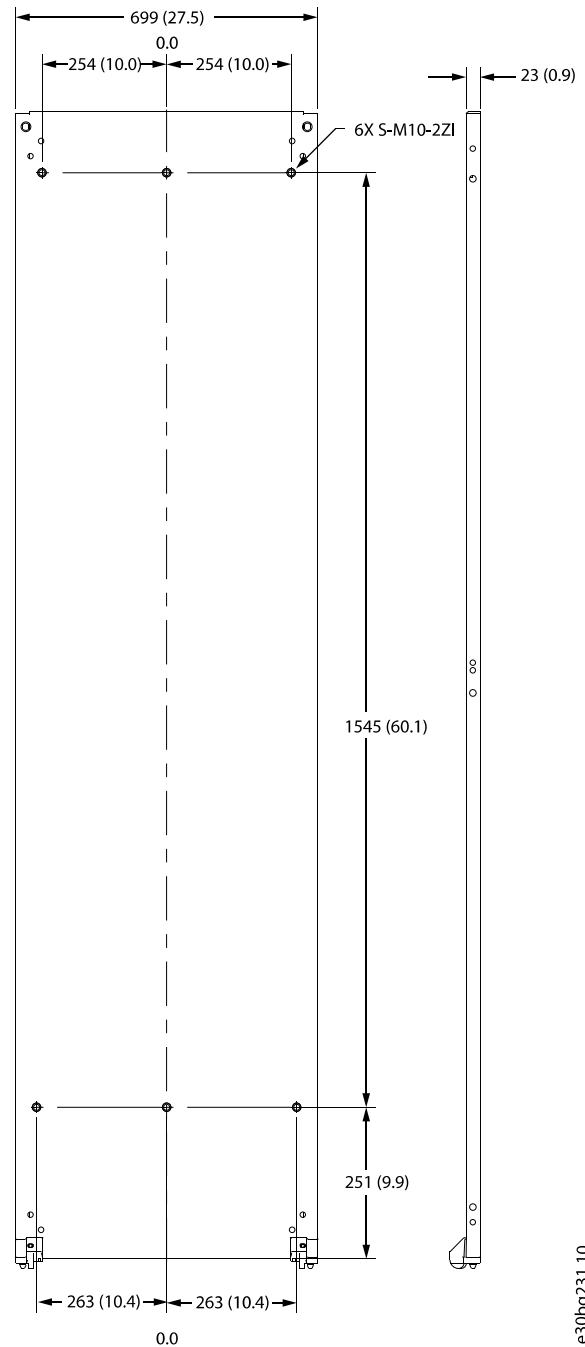

Illustration 1.4 Mounting Plate in 800 mm (32 in) Enclosure

1.3.2 Creating a Vent Opening in the Enclosure Top Plate

To create a vent opening in the enclosure top plate to match the top vent of the drive and top duct, use the following steps. Refer to *Illustration 1.5* and *Illustration 1.6*.

1. Cut out the vent opening in the enclosure top plate. The opening must match the drive vent opening.
2. Drill 6 screw holes (6 mm) around the vent opening. The holes must match the holes in the upper flange of the top duct.

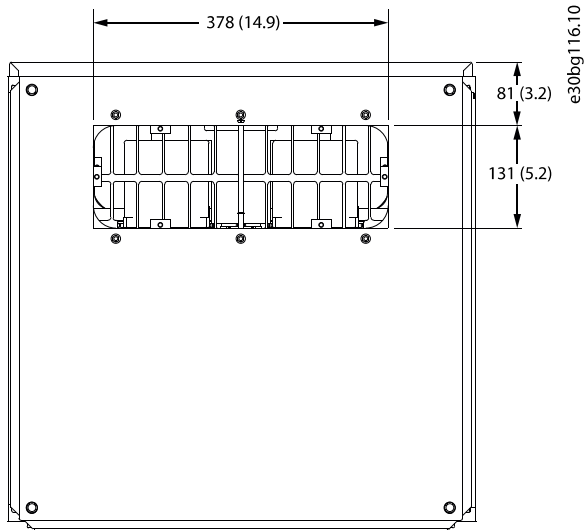

Illustration 1.5 Dimensions of Vent in Top of Drive

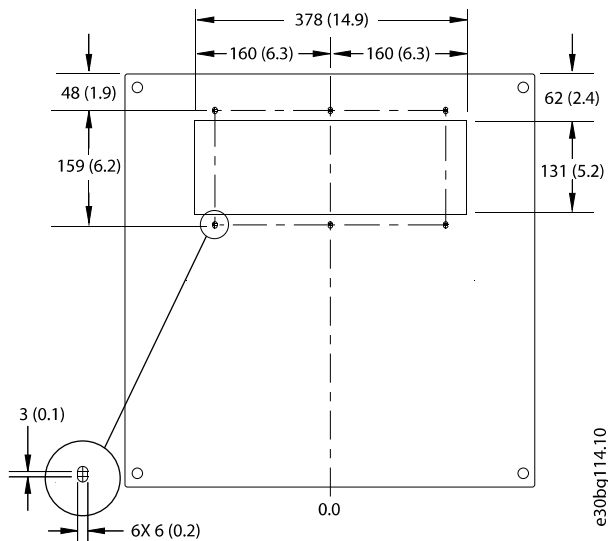
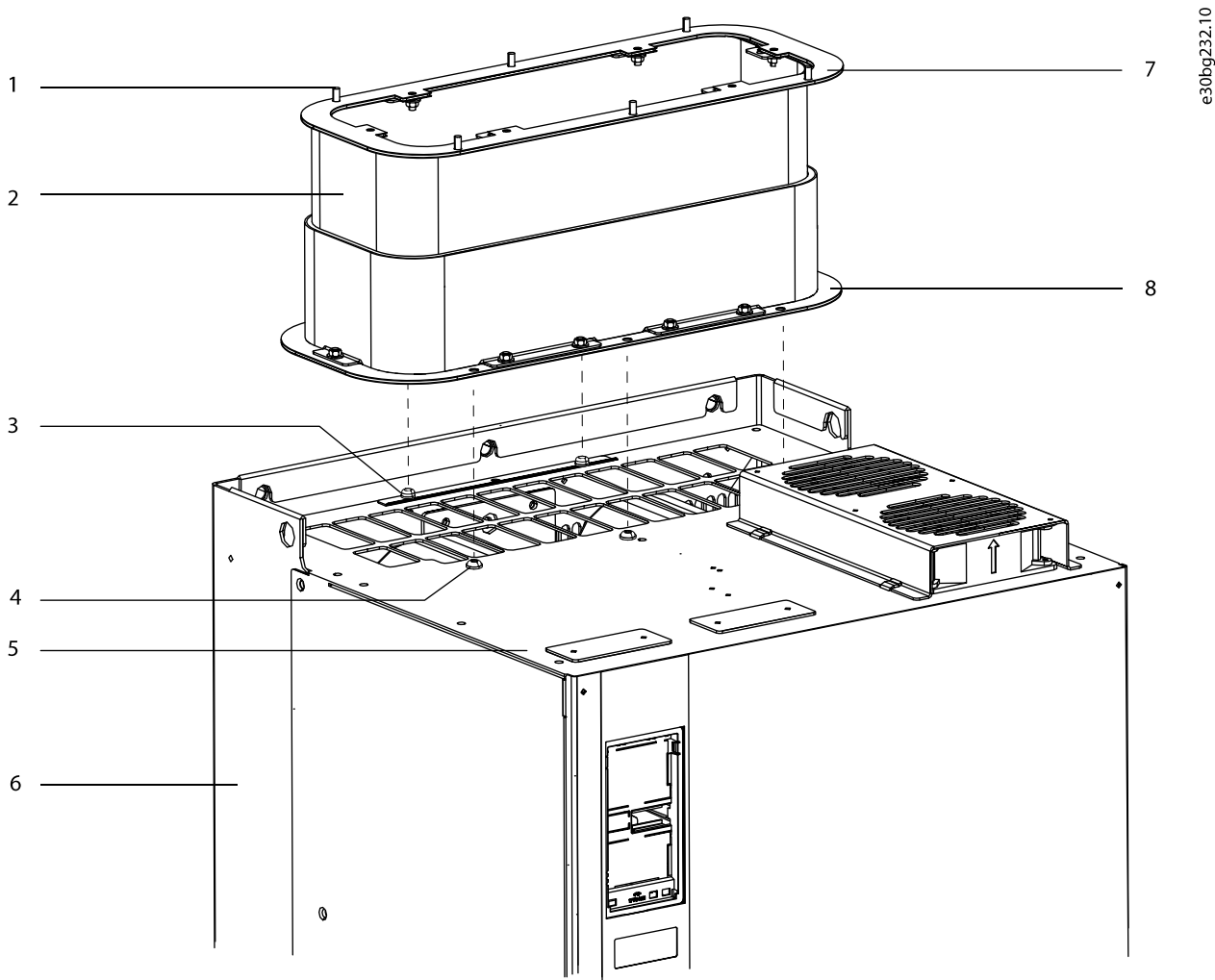

Illustration 1.6 Dimensions for Opening in Enclosure Top Plate

1.3.3 Installing the Top Duct Over the Drive Top Vent

The top duct is a pre-assembled, telescoping duct that collapses to simplify installation. To attach the top duct over the top vent of the drive, use the following procedure. See *Illustration 1.7*.

1. Remove 2 M5x14 screws (T25) at the back of the vent in the top of the drive. Retain the screws.
2. Remove 3 M5x12 screws (T25) at the front of the vent in the top of the drive. Retain the screws.
3. Position the top duct over the vent in the top of the drive. Line up the holes in the lower flange with the screw holes in the drive.
4. Secure the lower flange to the drive with the 5 screws (T25) previously removed. Torque fasteners to 2.3 Nm (20 in-lb).
5. Collapse the duct until installation of the enclosure top plate.



1	Threaded stud	5	Top of drive
2	Top duct	6	Cooling back channel
3	M5x14 screw	7	Upper flange of duct
4	M5x12 screw	8	Lower flange of duct

Illustration 1.7 Installation of the Top Duct Over the Top Vent of the Drive

1.3.4 Installing the Bottom Bracket

The bottom bracket attaches the bottom air duct to the lower end of the cooling back channel. To install the bracket, use the following steps. Refer to *Illustration 1.8*.

1. Remove the paper backing from the bottom gasket. Adhere the gasket to the upper surface of the bottom bracket.
2. Position the bracket at the lower end of the cooling back channel.
3. Secure the bracket to the back channel of the drive using 8 M5x14 screws (T25) from the kit. Torque fasteners to 2.3 Nm (20 in-lb).

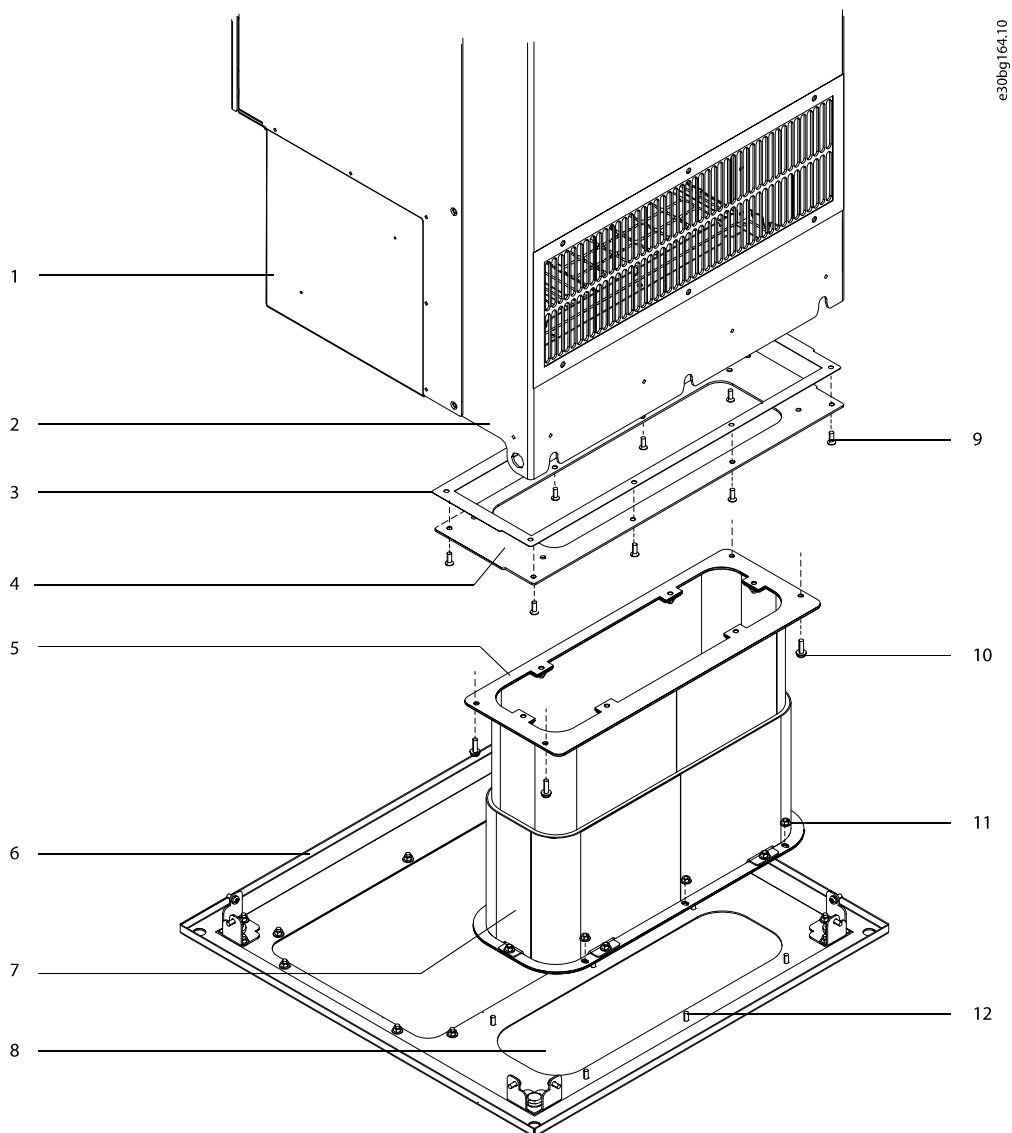

1	Drive	7	Bottom duct assembly
2	Back channel	8	Opening for duct
3	Bottom gasket	9	M5x14 screw
4	Bottom bracket	10	M5x18 screw
5	Upper flange of duct	11	M5 hex nut
6	Enclosure base plate	12	Threaded stud

Illustration 1.8 Installation of the Bottom Bracket

1.3.5 Installing the Base Plate and Bottom Duct

The bottom duct is a pre-assembled telescoping duct that collapses to simplify installation. To attach the bottom duct to the base plate of the enclosure, use the following steps. Refer to *Illustration 1.9*.

1. Remove the base plate from the Rittal enclosure. Replace it with the base plate from the kit, which has a vent opening for the bottom duct.
2. Position the bottom duct over the vent opening in the base plate. Place the holes in the lower flange of the duct over the 6 threaded studs surrounding the opening in the plate.
3. Fasten 6 M5 hex nuts (T25) to the threaded studs.
4. Collapse the duct and install the plate between the pedestal and the enclosure frame, using the existing fasteners. Refer to *Illustration 1.10*.

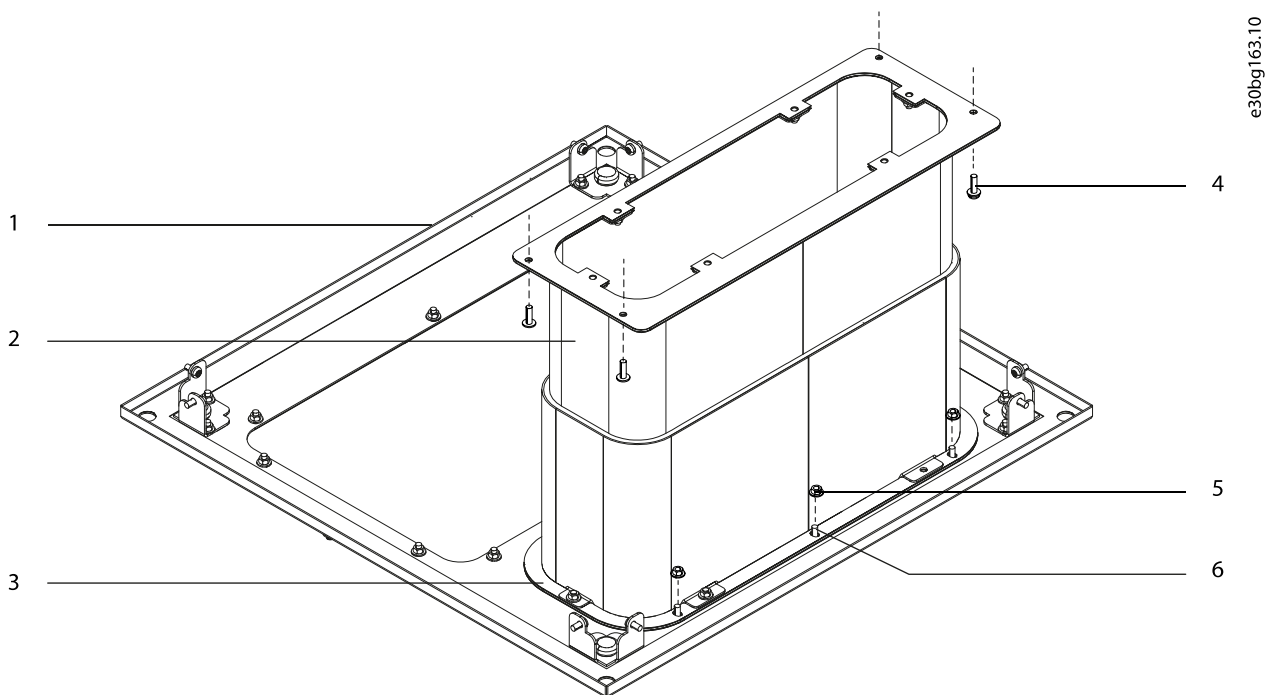

Illustration 1.9 Installation of the Bottom Duct on the Base Plate

1	Base plate (with opening for duct)	4	M5x18 screw
2	Bottom duct assembly	5	M5 hex nut
3	Lower flange of duct	6	Threaded stud

1.3.6 Mounting the Drive in the Enclosure

To install the mounting plate and drive in the enclosure, use the following steps. Refer to *Illustration 1.10*.

1. Attach the mounting plate to the enclosure rails, making sure that the pem nuts face the back of the enclosure.
2. Loosely fasten 3 M10 screws (not supplied in kit) into the pem nuts at the lower end of the mounting plate. Make sure that the screws are secure since the base of the drive rests on these screws.
3. Slightly lean the top of the drive forward and set the cutouts in the base onto the 3 screws in the mounting plate.
4. Slowly push the top of the drive back against the mounting plate until the top 3 pem nuts line up with the holes in the drive. Secure the top of the drive using 3 M10 screws.

5. Torque all 6 M10 screws to 19 Nm (170 in-lb).

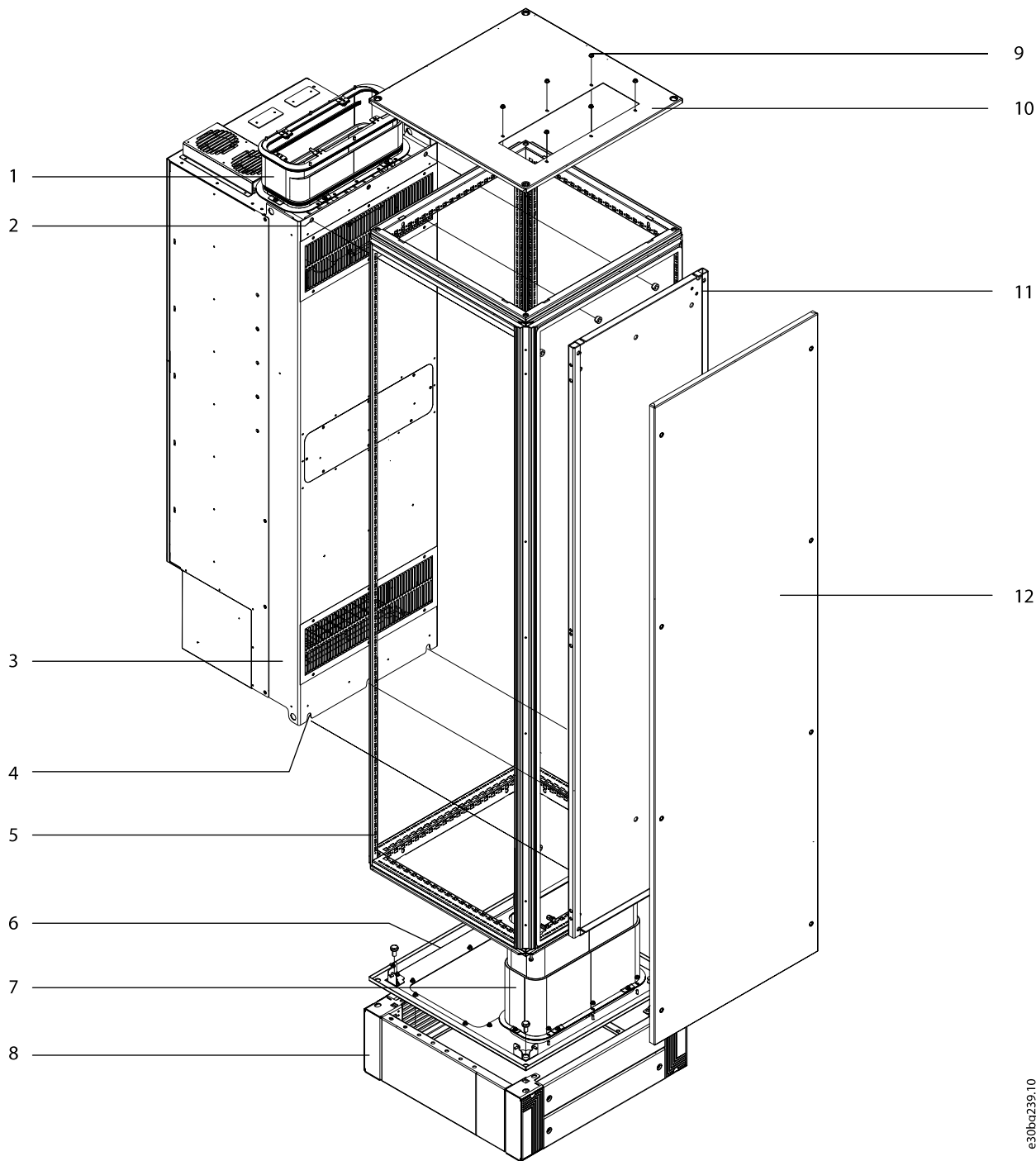

1	Top duct assembly	7	Bottom duct assembly
2	Upper mounting holes	8	Pedestal
3	Cooling back channel	9	M5 hex nut
4	Cutouts for mounting	10	Enclosure top plate
5	Enclosure rails	11	Mounting plate
6	Enclosure bottom plate	12	Enclosure backplate

e30bg239.10

Illustration 1.10 Installation of the Drive, Mounting Plate, Backplate, and Top Plate

1.3.7 Attaching the Bottom Duct to the Bottom Bracket

After the drive is installed on the mounting plate, attach the bottom duct to the bottom bracket using the following procedure. See *Illustration 1.8*.

1. Extend the telescoping bottom duct upward until the upper flange of the duct is positioned against the bottom bracket.
2. Secure the duct to the bracket with 4 M5x18 screws (T25) from the kit. Torque fasteners to 2.3 Nm (20 in-lb).

1.3.8 Attaching the Top Duct to the Enclosure Top Plate

After the drive is installed on the mounting plate, attach the top duct to the enclosure top plate using the following procedure. Refer to *Illustration 1.2*.

1. Extend the telescoping bottom duct upward until the upper flange of the duct is positioned against the underside of the enclosure top plate.
2. Secure the duct to the top plate with 6 M5 hex nuts (T25) from the kit. Torque fasteners to 2.3 Nm (20 in-lb).

1.3.9 Installing the Backplate

To attach the backplate of the Rittal enclosure, use the following steps. Refer to *Illustration 1.10*.

1. Position the backplate on the back rails of the enclosure behind the drive mounting plate.
2. Secure the backplate to the rails behind the mounting plate using the existing fasteners.

Danfoss can accept no responsibility for possible errors in catalogues, brochures and other printed material. Danfoss reserves the right to alter its products without notice. This also applies to products already on order provided that such alterations can be made without consequential changes being necessary in specifications already agreed. All trademarks in this material are property of the respective companies. Danfoss and the Danfoss logotype are trademarks of Danfoss A/S. All rights reserved.

