

Installation Instructions

In-bottom/Out-top Cooling Duct Kit (D3h/D4h)

VLT[®] FC Series FC 102, FC 103, FC 202, FC 302

Description

The in-bottom/out-top cooling duct kit includes all parts required to install the ducts with a D3h or D4h drive. These instructions show installation in a Rittal enclosure: height = 2000 mm (79 in), width = 600 mm (24 in) or 800 mm (31 in).

Kit Ordering Numbers

Kit number	Kit description
176F6760	Duct, In-bottom/Out-top, D3h
176F6761	Duct, In-bottom/Out-top, D4h

Table 1.1 Ordering Numbers for torsIn-bottom/Out-top Cooling Duct Kit

Items Supplied

Item	Quantity
Telescoping top duct	1
Telescoping bottom duct	1
Cutout gasket	1
Drive slot gasket	1
Seal plate gasket	2
Seal plate	2
Bottom adapter plate	1
Adapter plate gasket	1
M10x30 screws	4
M5x16 screw	11
M5x18 screw	4
M8 hex nut	6
M5 screw	6

Table 1.2 Items Supplied with In-bottom/Out-top Cooling Duct Kit

Safety Information

Only qualified, Danfoss authorized personnel are allowed to install the parts described in these installation instructions. Handling of the drive and its parts must be done in accordance with the corresponding *operating guide*.

⚠️WARNING

ELECTRICAL SHOCK HAZARD

VLT[®] FC series drives contain dangerous voltages when connected to mains voltage. Improper installation, and installing or servicing with power connected, can cause death, serious injury, or equipment failure.

To avoid death, serious injury, or equipment failure:

- Only use qualified electricians for the installation.
- Disconnect the drive from all power sources before installation or service.
- Treat the drive as live whenever the mains voltage is connected.
- Follow the guidelines in these instructions and local electrical safety codes.

⚠️WARNING

DISCHARGE TIME

The drive contains DC-link capacitors, which can remain charged even when the drive is not powered. High voltage can be present even when the warning LED indicator lights are off. Failure to wait the specified time after power has been removed before performing service or repair work can result in death or serious injury.

- Stop the motor.
- Disconnect AC mains and remote DC-link power supplies, including battery back-ups, UPS, and DC-link connections to other drives.
- Disconnect or lock PM motor.
- Wait for the capacitors to discharge fully. The minimum waiting time is 20 minutes.
- Before performing any service or repair work, use an appropriate voltage measuring device to make sure that the capacitors are fully discharged.

Installation Instructions

NOTICE

APPLYING GASKETS

This kit contains gaskets to ensure a proper seal between metal parts. Before adhering a gasket to a part, check that the part matches the gasket and that no holes are covered.

General Torque Tightening Values

For tightening fasteners, use the values listed in *Table 1.3*. Use a torque wrench to ensure that correct torque is applied.

Shaft size	Torx/hex drives size	Nm (in-lb)
M4	T20/7 mm	1.2 (10)
M5	T25/8 mm	2.3 (20)
M6	T30/10 mm	3.9 (35)
M8	T40/13 mm	9.6 (85)
M10	T50/17 mm	19.1 (169)
M12	-/18 mm or 19 mm	37.9 (335)

Table 1.3 Torque Values Standard Thread

Creating a Vent Opening in the Top Plate

To create a vent opening in the enclosure top plate for the top duct, use the following steps. Refer to *Illustration 1.1* for D3h dimensions, and *Illustration 1.2* for D4h dimensions.

1. Cut out the vent opening in the enclosure top plate. The opening must match the drive vent opening.
2. Drill 6 screw holes (4 mm) around the vent opening. The holes must match the holes in the upper flange of the top duct.

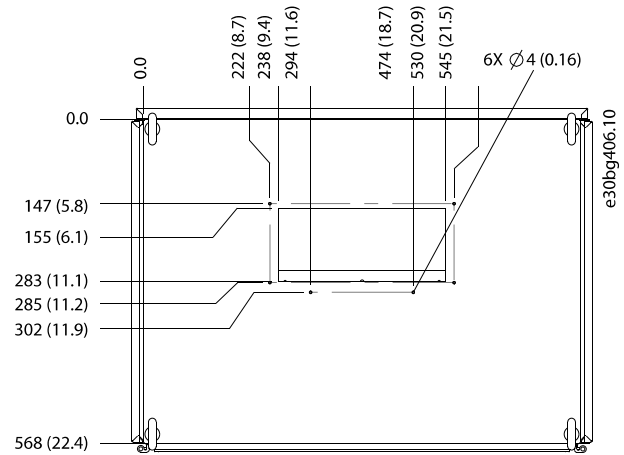

Illustration 1.2 Dimensions of Top Vent Opening in D4h Enclosure

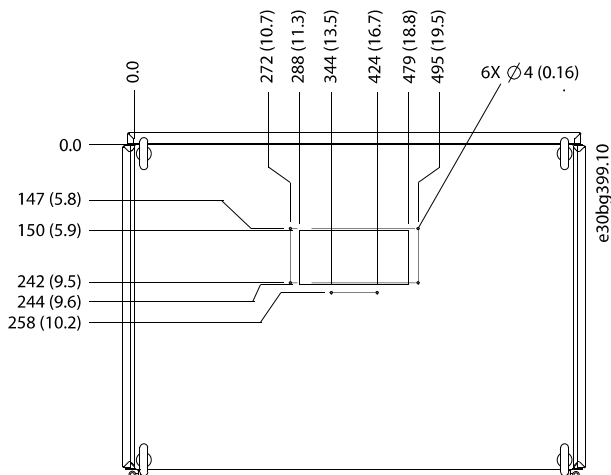

Illustration 1.1 Dimensions of Top Vent Opening in D3h Enclosure

Creating a Vent Opening in the Base Plate

To create a vent opening in the enclosure base plate for the bottom duct, use the following steps.

1. Cut out the vent opening in the enclosure base plate. Refer to *Illustration 1.3* for D3h dimensions, and *Illustration 1.4* for D4h dimensions.
2. Drill 6 screw holes (4 mm) around the vent opening. The holes must match the holes in the lower flange of the bottom duct.

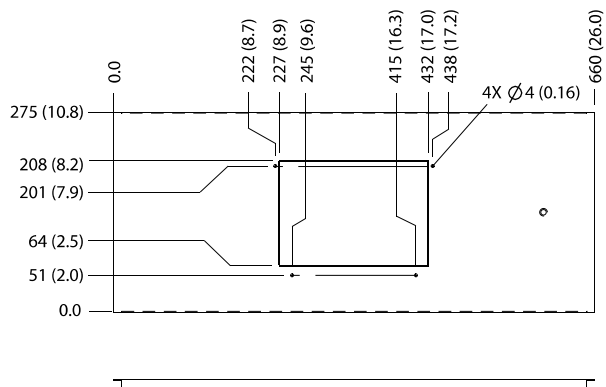
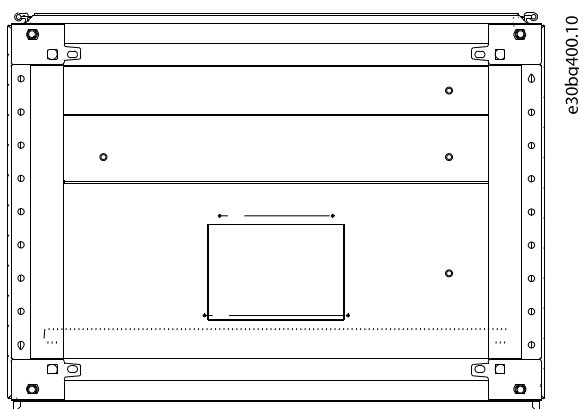

Illustration 1.3 Base Plate Opening in D3h Enclosure

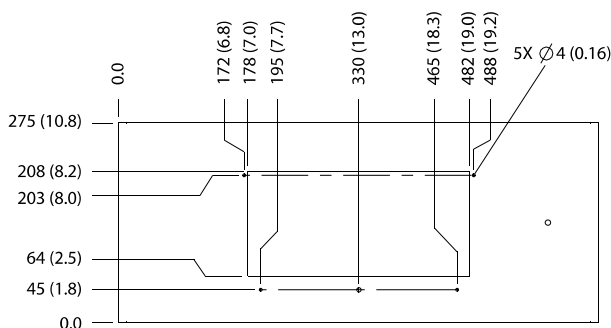
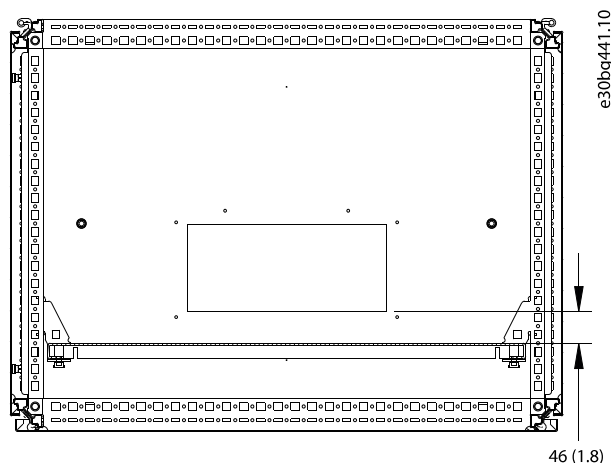
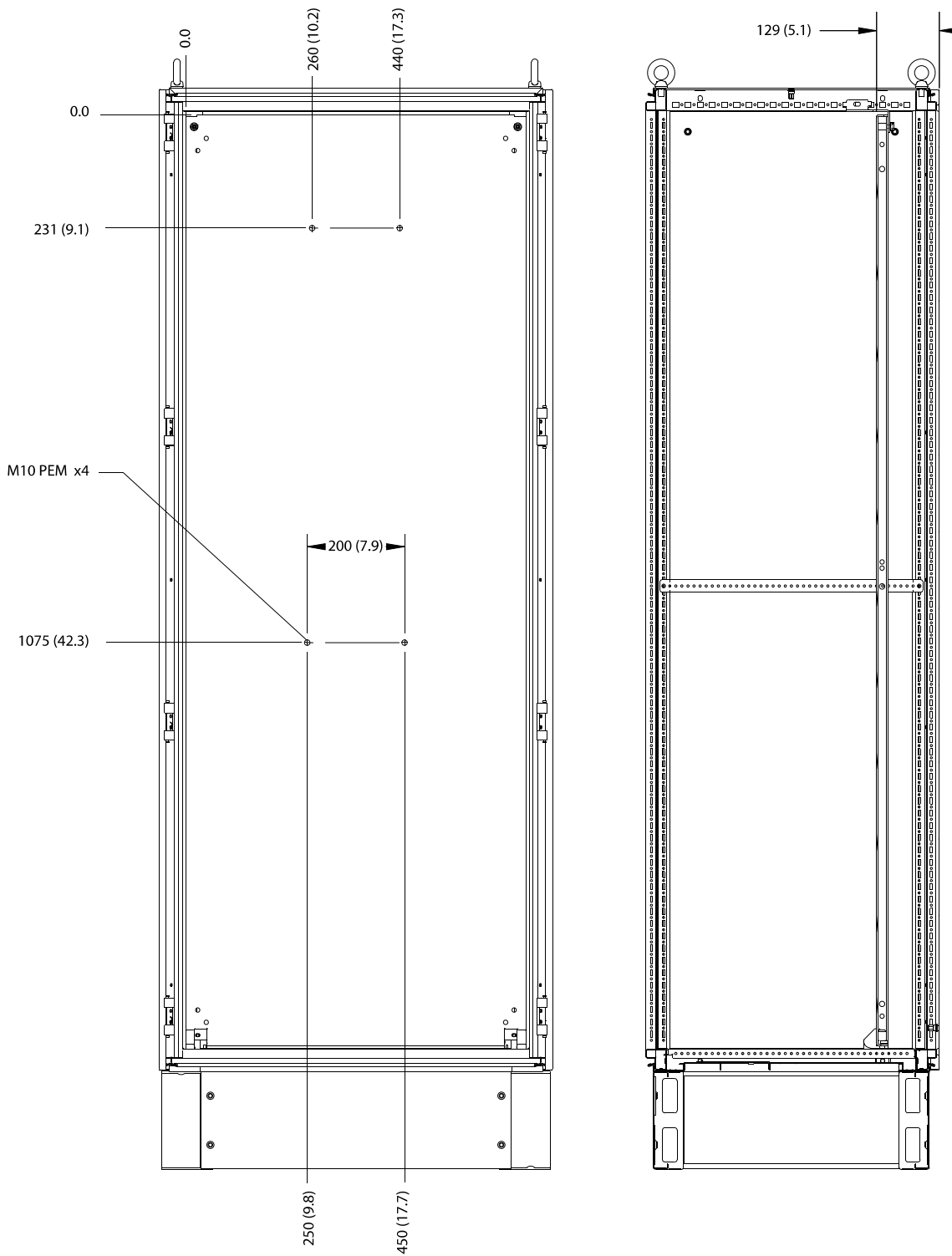

Illustration 1.4 Base Plate Opening in D4h Enclosure

Preparing the Mounting Plate

To create mounting holes in the mounting plate, use the following steps. Refer to *Illustration 1.5* for D3h enclosures, and *Illustration 1.6* for D4h enclosures.

1. Drill 4 mounting holes in the mounting plate using the dimensions in *Illustration 1.5* and *Illustration 1.6*. The holes must match the holes in the drive.
2. Insert 4 M10 pem self-clinching nuts (not supplied) in the mounting holes.



e30bg401.10

Illustration 1.5 Mounting Plate Dimensions in D3h Enclosure

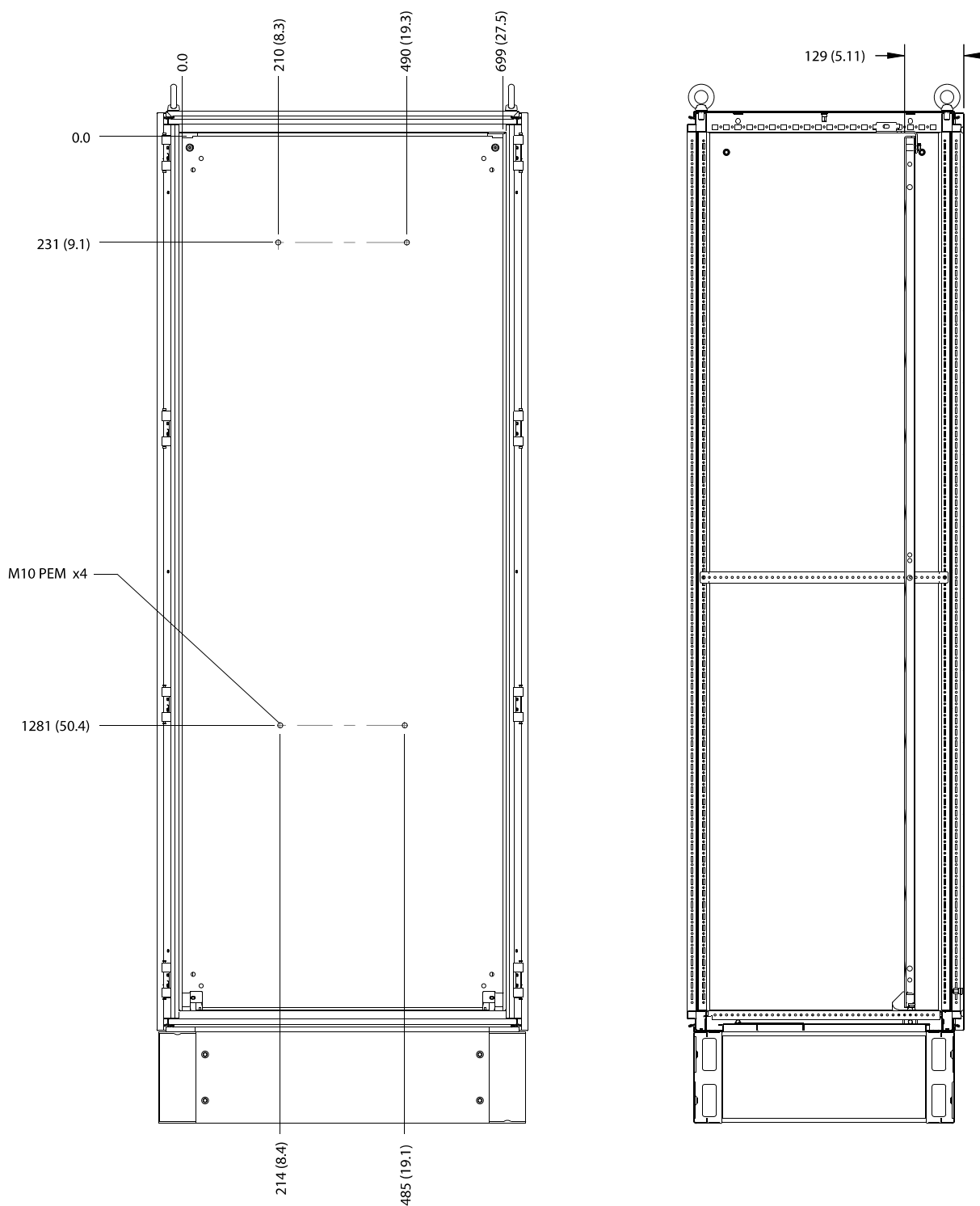
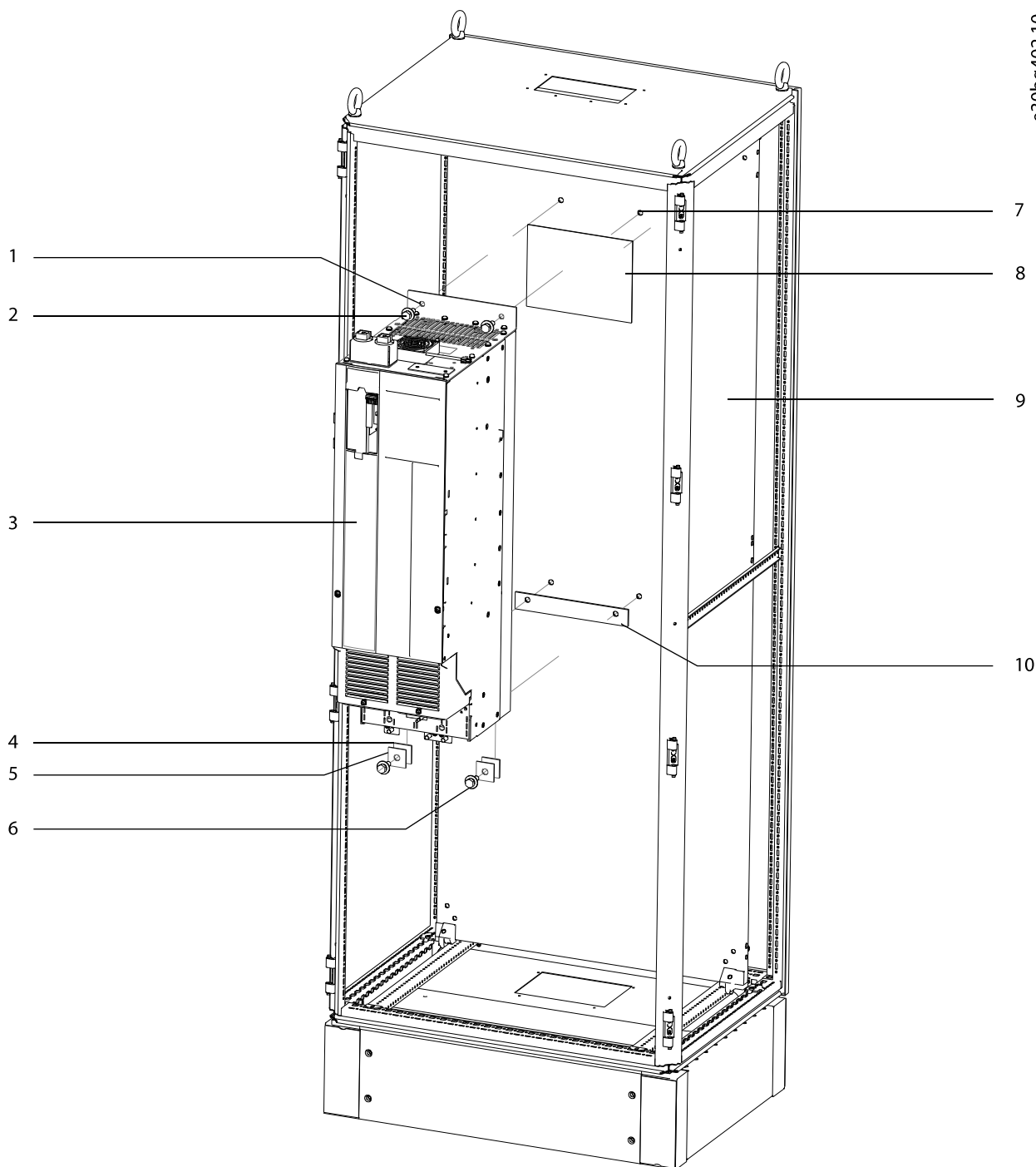

Illustration 1.6 Mounting Plate Dimensions in D4h Enclosure

Mounting the Drive in the Enclosure

To install the mounting plate and drive in the Rittal enclosure, use the following steps. Refer to *Illustration 1.7*.

1. Attach the mounting plate to the enclosure rails, making sure that the PEM nuts face the back of the enclosure.
2. Remove the backing paper from the self adhesive on the cutout gasket. Affix the gasket over the duct opening in the mounting plate.
3. Remove the backing paper from the self adhesive on the drive slot gasket. Affix the gasket over the lower 2 PEM nuts in the mounting plate.
4. Remove the backing paper from the 2 seal plate gaskets, and affix the gaskets to the seal plates, 1 per plate.
5. Fasten 2 M10x30 screws through the seal plates, 1 per plate, and into the PEM nuts at the lower end of the mounting plate. Make sure that the screws are secure since the base of the drive rests on the screws.
6. Slightly lean the top of the drive forward and set the cutouts in the base onto the 2 screws in the mounting plate.
7. Slowly push the top of the drive back against the mounting plate until the top 2 PEM nuts line up with the holes in the drive. Secure the top of the drive using 2 M10x30 screws.
8. Torque all M10x30 screws to 19 Nm (170 in-lb).



1	Mounting holes	6	M10x30 screw
2	M10x30 screw	7	PEM nuts
3	Drive	8	Cutout gasket
4	Seal plate gasket	9	Mounting plate
5	Seal plate	10	Drive slot gasket

Illustration 1.7 Installation of the Drive on the Mounting Plate

Installing the Bottom Adapter Plate

The bottom adapter plate attaches the bottom air duct to the lower end of the cooling back channel. To install the adapter plate, use the following steps. Refer to *Illustration 1.8*.

1. Remove the paper backing from the adapter plate gasket. Adhere the gasket to the upper surface of the bottom adapter plate.
2. Position the adapter plate at the lower end of the cooling back channel.
3. Secure the adapter plate to the back channel of the drive using 7 M5x16 countersunk screws (T25). Torque fasteners to 2.3 Nm (20 in-lb).

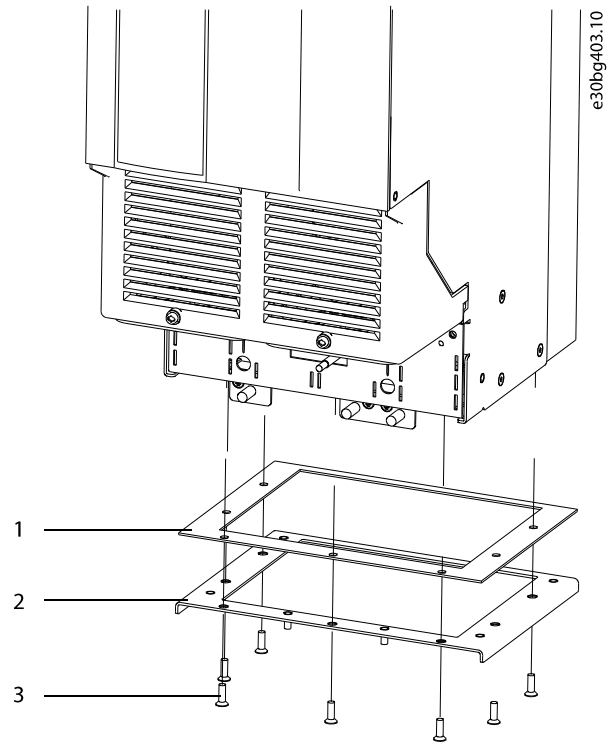

1	Adapter plate gasket
2	Bottom adapter plate
3	M5x16 countersunk screw

Illustration 1.8 Installation of the Bottom Adapter Plate

Installing the Bottom Duct

The bottom duct is a pre-assembled telescoping duct that collapses to simplify installation. To attach the bottom duct to the base plate of the enclosure, use the following steps. Refer to *Illustration 1.9*.

1. Install the base plate into the Rittal cabinet using the existing fasteners.
2. Collapse the bottom duct and position it over the vent cutout in the base plate. Place the holes in the lower flange of the duct over the holes surrounding the opening in the plate.
3. Fasten 4 M5x16 screws (T25) through the holes in the lower flange of the duct, securing it to the base plate.
4. Extend the duct upward and fasten with 6 M5 hex nuts, securing it to the bottom adapter plate.

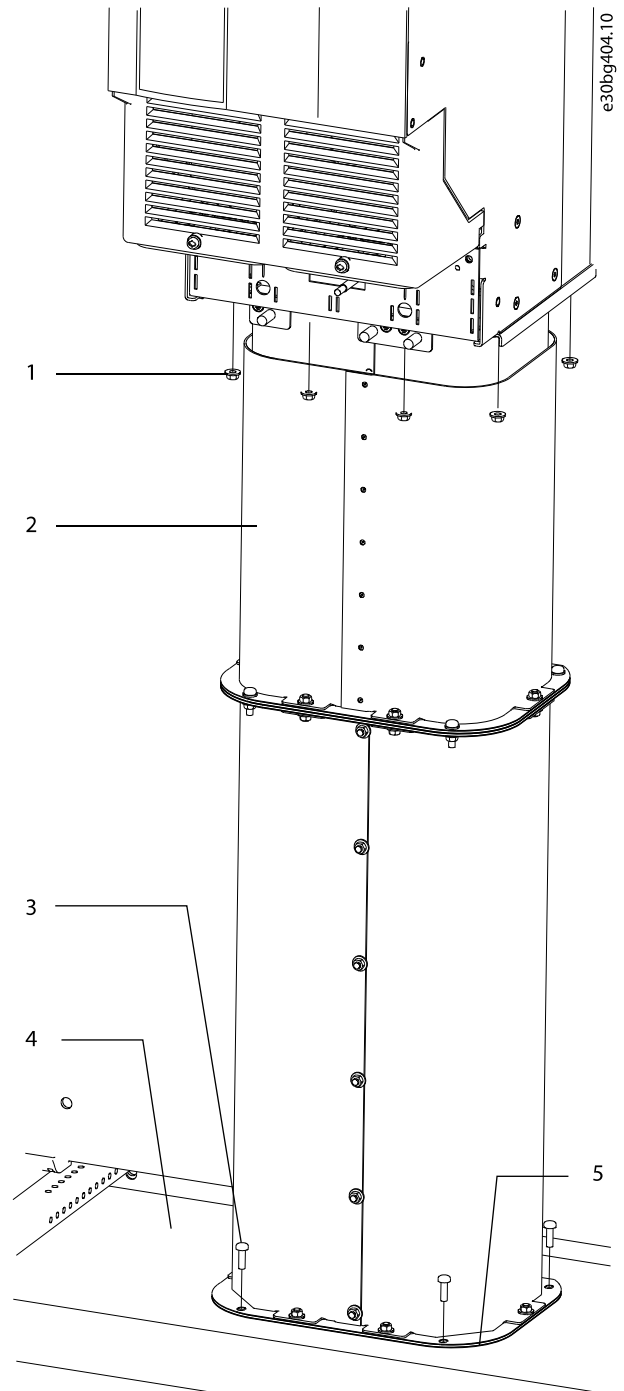

1	M5 hex nut
2	Bottom telescoping duct
3	M5x16 screw
4	Base plate
5	Lower flange of duct

Illustration 1.9 Installation of the Bottom Duct

Installing the Top Duct

Attach the top telescoping duct between the top of the drive and the enclosure using the following steps. Refer to *Illustration 1.10*. (The top plate of the enclosure is removed from the illustration for visibility of parts).

1. Collapse the top duct and position it over the vent in the top of the drive. Secure the duct to the top of the drive with 4 M5x18 screws.
2. Extend the telescoping duct upward until the upper flange of the duct is positioned against the underside of the enclosure top plate.
3. Secure the duct to the top plate with 6 M5 screws (T25) through the upper flange of the duct. Torque fasteners to 2.3 Nm (20 in-lb).

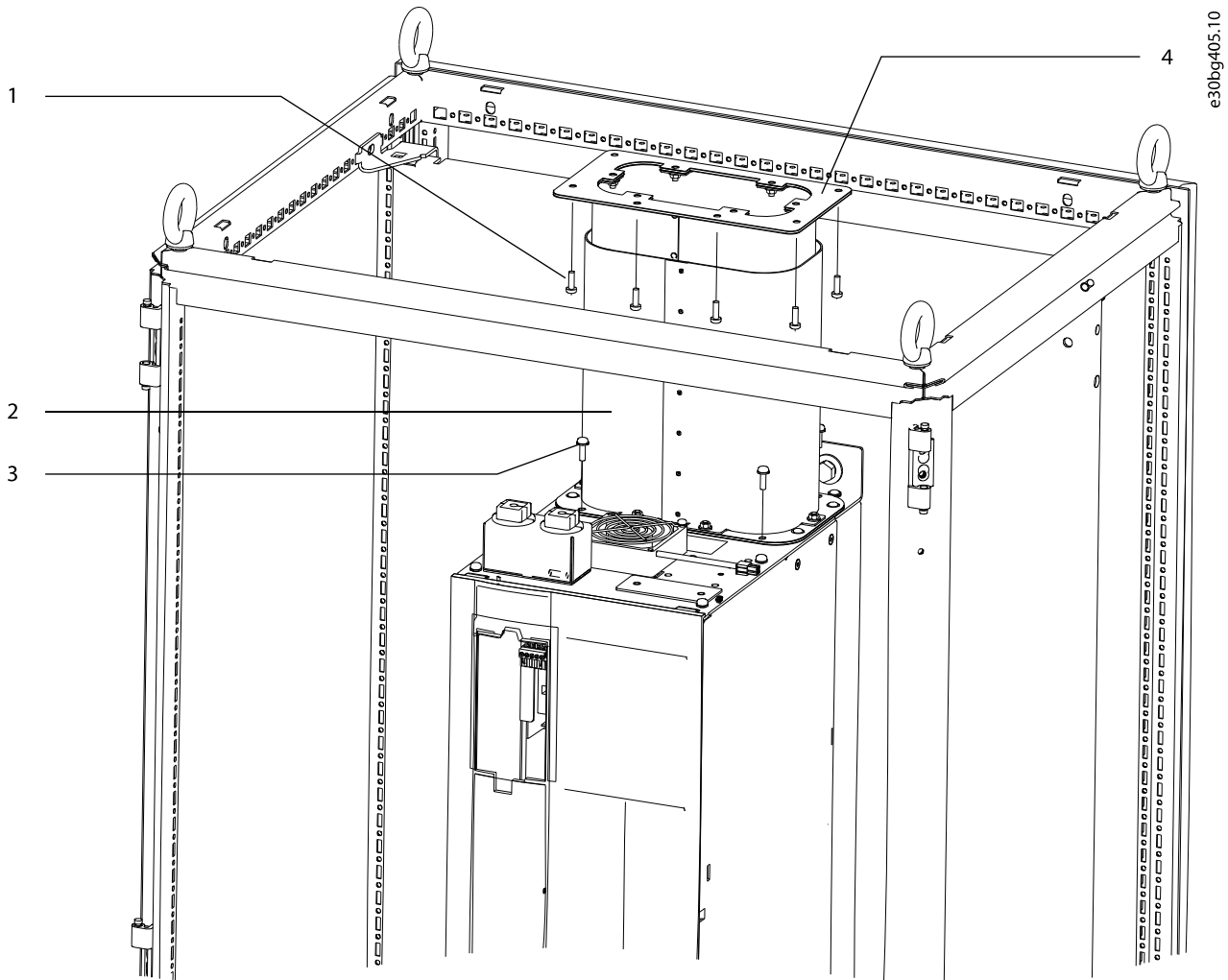

1	M5 screw	3	M5x18 screw
2	Telescoping top duct	4	Upper flange of duct

Illustration 1.10 Installation of the Top Duct

Danfoss can accept no responsibility for possible errors in catalogues, brochures and other printed material. Danfoss reserves the right to alter its products without notice. This also applies to products already on order provided that such alterations can be made without consequential changes being necessary in specifications already agreed. All trademarks in this material are property of the respective companies. Danfoss and the Danfoss logotype are trademarks of Danfoss A/S. All rights reserved.

