

Installation Instructions

300 A/500 A Current Sensor Kit for D2h/D4h/D7h/D8h Drives

VLT[®] FC Series FC 102, FC 103, FC 202, FC 302

1.1 Description

The 300 A and 500 A current sensor kits are designed for D2h/D4h/D7h/D8h drives in the power ranges shown in *Table 1.1* and *Table 1.2*. To identify the power rating, see *chapter 1.1.1 Identifying the Power Rating*.

Product group and series	Voltage rating (V)	Power rating [kW (hp)]
VLT [®] HVAC Drive FC 102, VLT [®] Refrigeration Drive FC 103, VLT [®] AQUA Drive FC 202	(T4) 380–480	110–200 (150–300)
	(T7) 525–690	75–315 (75–350)
VLT [®] AutomationDrive FC 302	(T5) 380–500	90–160 (125–200)
	(T7) 525–690	55–250 (75–350)

Table 1.1 Applicable Power Ranges for 300 A Current Sensor Kit

Product group and series	Voltage rating [V]	Power rating [kW (hp)]
VLT [®] HVAC Drive FC 102, VLT [®] Refrigeration Drive FC 103, VLT [®] AQUA Drive FC 202	(T4) 380–480	200–315 (300–450)
	(T7) 525–690	200–400 (250–400)
VLT [®] AutomationDrive FC 302	(T5) 380–500	200–250 (300–350)
	(T7) 525–690	160–315 (200–350)

Table 1.2 Applicable Power Ranges for 500 A Current Sensor Kit

1.1.1 Identifying the Power Rating

To find the drive power rating, use the following steps:

- Obtain the following information from the nameplate, which is on the drive. Refer to *Illustration 1.1*.
 - Product group and drive series (characters 1–6)
 - Power rating (characters 7–10)
 - Voltage rating (phases and mains) (characters 11–12)
- Determine if the power rating is in *Table 1.1* and *Table 1.2*.

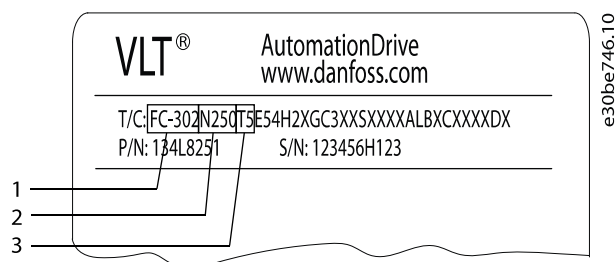

1	Product group and drive series
2	Power rating
3	Voltage rating (phases and mains)

Illustration 1.1 Example Nameplate

1.1.2 Kit Ordering Numbers

Kit number	Kit description
176F3752	300 A Current Sensor Conversion Kit D2h/D4h/D7h/D8h
176F3737	500 A Current Sensor Conversion Kit D2h/D4h/D7h/D8h

Table 1.3 Kit Numbers for 300 A and 500 A Current Sensor Kits

1.1.3 Items Supplied

Table 1.4 provides a list of items included in the 300 A and 500 A current sensor kits for D2h/D4h/D7h/D8h drives. Refer also to *Illustration 1.4*.

Description	Quantity
R/S/T terminal label	1
M10x30 machine screw with captive washer	6
M10 nut	6
Mains input terminal block	1
M5x12 machine screw	12
U/V/W terminal label	1
Motor terminal block	1
Cable retaining clip	6
M10 nut with captive washer	4
Cable clamp adapter	2
Power terminal mounting plate (IP21/IP54)	1
Power terminal mounting plate (IP20/Chassis)	1
Mixing fan	1
Mixing fan housing	1
EMC shield	1
Plastic mounting button	3
Motor busbar (U)	1
Motor busbar (V)	1
Motor busbar (W)	1
Busbar insulator sleeve	1
M5x16 torx screw	3
M8x70 screw	3
Cylinder busbar	3
Nomex tube	3
300 A or 500 A current sensor	3
Wire harness (current sensor cables)	1
M4x10 thread-forming screw	6
M5 nut	2
Wire harness (current sensor cables)	1
Multiple wire guide, not shown	4
Wire routing clip, not shown	1
M5x11 thread-cutting screw, not shown	6
IGBT busbar (300 A kit only)	3

Table 1.4 Items Supplied in 300/500 A Current Sensor Kit

1.2 Safety Information

Only qualified, Danfoss-authorized personnel are allowed to install the parts described in these installation instructions. Handling of the drive and its parts must be done in accordance with the corresponding *operating guide*.

⚠ WARNING

ELECTRICAL SHOCK HAZARD

VLT® FC series drives contain dangerous voltages when connected to mains voltage. Improper installation, and installing or servicing with power connected, can cause death, serious injury, or equipment failure.

To avoid death, serious injury, or equipment failure:

- Only use qualified electricians for the installation.
- Disconnect the drive from all power sources before installation or service.
- Treat the drive as live whenever the mains voltage is connected.
- Follow the guidelines in these instructions and local electrical safety codes.

⚠ WARNING

DISCHARGE TIME

The drive contains DC-link capacitors, which can remain charged even when the drive is not powered. High voltage can be present even when the warning LED indicator lights are off. Failure to wait the specified time after power has been removed before performing service or repair work can result in death or serious injury.

- Stop the motor.
- Disconnect AC mains and remote DC-link power supplies, including battery back-ups, UPS, and DC-link connections to other drives.
- Disconnect or lock PM motor.
- Wait for the capacitors to discharge fully. The minimum waiting time is 20 minutes.
- Before performing any service or repair work, use an appropriate voltage measuring device to make sure that the capacitors are fully discharged.

NOTICE

ELECTROSTATIC DISCHARGE

Follow proper ESD precautions to prevent damage to sensitive components.

1.3 Disassembly Guidelines

NOTICE

To make the disassembly/reassembly process easier, use these general guidelines:

1. Follow the disassembly instructions for each component.
2. Place the component together with the removed fasteners.
3. Replace old component with the new component provided in the kit.
4. If any fasteners are stripped or lost, replace with similar fastener from the kit.
5. Follow the assembly instructions to replace and secure each component.

1.3.1 General Torque Tightening Values

Use a torque wrench to ensure that correct torque is applied. Incorrect torque can cause electrical connection problems. For fastening hardware described in this instruction, use the values listed in *Table 1.5* to *Table 1.7* except where noted in the procedures.

Shaft size	Torx/hex drives size	Class A Nm (in-lb)	Class B Nm (in-lb)
M4	T20/7 mm	1.2 (10)	0.8 (7)
M5	T25/8 mm	2.3 (20)	1.2 (10)
M6	T30/10 mm	3.9 (35)	2.3 (20)
M8	T40/13 mm	9.6 (85)	3.9 (35)
M10	T50/17 mm	19.1 (169)	9.6 (85)
M12	-/18 mm or 19 mm	37.9 (335)	-

Table 1.5 Torque Values Standard Thread

Shaft size	Torx drives size	Class A Nm (in-lb)	Class B Nm (in-lb)
M4.8	T25	5.7 (50)	3.1 (27)
M5	T25	1.7 (15)	1.7 (15)

Table 1.6 Torque Values for Thread Cutting into Metal

Shaft size	Torx drives size	Class A Nm (in-lb)	Class B Nm (in-lb)
M4	T20	2.8 (24)	2.8 (24)
M5	T25	5.1 (45)	4.0 (35)

Table 1.7 Torque Values for Thread Forming into Plastic

Class A: Clamping metal

Class B: Clamping PCA or plastic

1.3.2 Removing AC Input Busbars

To remove the AC input busbars, use the following steps. The AC input busbars can look different when the drive includes extra input options, such as RFI filter or mains fuses.

Illustration 1.2 shows the AC input busbars configured to include mains fuses.

1. Remove the air baffle by removing 4 screws (T25) and 2 nuts (13 mm).
2. Disconnect the customer input power wiring.
3. The next step differs based on the input options present in the drive. Select the appropriate procedure for the drive:
 - No options
 - Mains fuses only
 - RFI filter only
 - Mains fuses and RFI filter

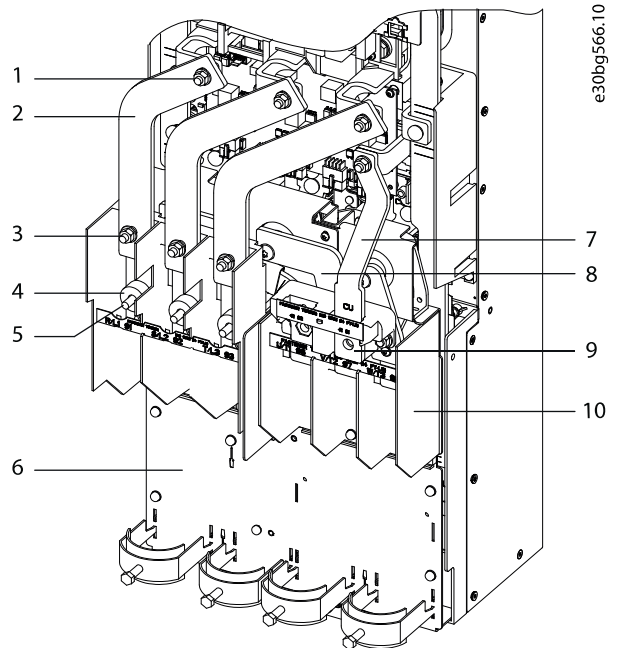

1	Top nut (13 mm)	6	Power terminal mounting plate
2	AC input busbar	7	Brake busbar (optional)
3	Bottom nut (13 mm)	8	U motor busbar
4	Fuse spacer	9	Brake terminal (optional)
5	Mains input terminal	10	Motor terminal block

Illustration 1.2 AC Input Busbars with Mains Fuse Configuration (Shown with Fuses Removed)

No options

1. Remove 3 nuts (13 mm), 1 from the top of each AC input busbar.
2. Remove 3 nuts (13 mm), 1 from the bottom of each AC input busbar.
3. Remove the AC input busbars from the drive.

Mains fuses only

1. Remove 3 AC fuses by removing 6 nuts (13 mm), 1 from each end of the fuses.
2. Remove 3 nuts (13 mm), 1 from the top of each AC input busbar.
3. Remove the AC input busbars from the drive.

RFI filter only

1. Remove 3 nuts (13 mm) at the top of the RFI filter, 1 per phase.
2. Remove 6 nuts (13 mm) at the bottom of the RFI filter, 2 per phase.
3. Remove 4 thread-cutting screws (T20), which connect the RFI filter to the side channels of the drive.
4. Unplug the RFI cable from the MK100 connector on the RFI printed circuit card.
5. Lift the RFI filter from the drive.

Mains fuses and RFI filter

1. Remove 3 AC fuses by removing 6 nuts (13 mm), 1 from each end of the fuses.
2. Remove 3 nuts (13 mm) from the top of the RFI filter, 1 per phase.
3. Remove 4 thread-cutting screws (T20), which connect the RFI filter to the side channels of the drive.
4. Unplug the RFI cable from the MK100 connector on the RFI printed circuit card.
5. Lift the RFI filter from the drive.

1.3.3 Removing Mains Input Terminal Block

To remove the mains input terminal block, use the following steps. Refer to *Illustration 1.4*.

1. Remove 2 screws (T25) at the bottom of the mains input terminal block.
2. Release the current sensor wiring from the cable retaining clips.
3. Slide the mains input terminal block downward to disengage it from the 2 metal clips holding it in place.

1.3.4 Removing Brake Terminals (Optional)

Drives can be configured with optional brake terminals. To remove the brake terminals, if any, use the following steps.

1. Disconnect the customer brake wiring, if present.
2. Remove the R (+) terminal:
 - 2a Unfasten 1 thread-forming screw (T25) at the terminal block.
 - 2b Unfasten 1 additional screw (T40).
3. Remove the R (-) terminal:
 - 3a Unfasten 1 thread-forming screw (T25) at the terminal block.
 - 3b Unfasten 1 additional nut (13 mm).
4. Remove 2 nuts (13 mm) and lift the brake terminal block from the drive.

1.3.5 Removing Motor Terminal Block

To remove the motor terminal block, use the following steps. Refer to *Illustration 1.4*.

1. Disconnect wiring to the motor and remove the U/V/W terminal label.
2. Remove the EMC shield by removing 1 screw (T25).
3. Remove the U motor busbar:
 - 3a Remove 1 thread-forming screw (T25) from the middle of the U busbar.
 - 3b Unfasten 1 bolt (T40) from the U busbar.
4. Remove the V motor busbar:
 - 4a Remove 1 thread-forming screw (T25) from the middle of the V busbar.
 - 4b Unfasten 1 bolt (T40) from the V busbar.
5. Remove the W motor busbar:
 - 5a Remove 1 thread-forming screw (T25) from the middle of the W busbar.
 - 5b Unfasten 1 bolt (T40) from the W busbar.
6. Remove 3 current sensor cylinder busbars.
7. Remove 2 screws (T25) from the bottom of the motor terminal block.
8. Remove the motor terminal block by sliding it down to disengage it from the 2 metal retaining clips.

1.3.6 Removing Power Terminal Mounting Plate

To remove the power terminal mounting plate, use the following steps. Refer to *Illustration 1.3*.

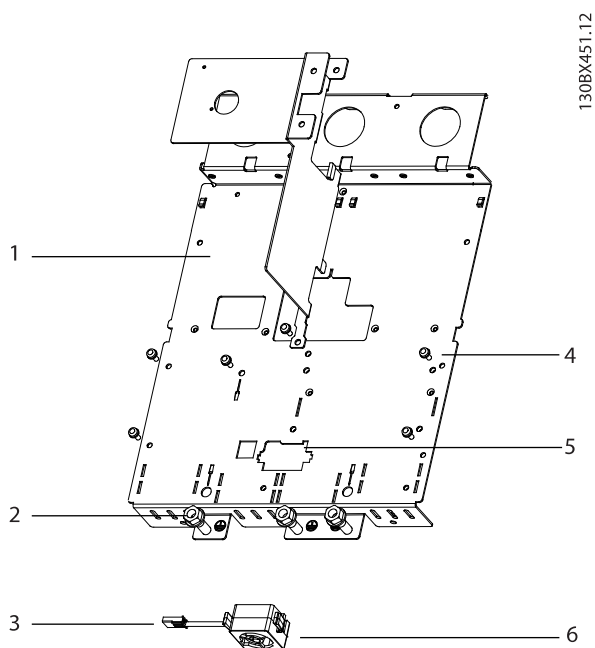

1. Remove 5 thread-cutting screws (T25) from the top of the plate. The fan screw can remain in place, if present.
2. Remove 2 nuts (8 mm).
3. Release the current sensor cables from the current sensors.
4. Unplug the wire harness from the power card, and discard it.
5. Lift the power terminal mounting plate and unplug the mixing fan cable that is located under the plate.
6. Remove the power terminal mounting plate with the old current sensors attached and discard it.

1	Power terminal mounting plate	4	Screw (T25)
2	Nut (8 mm)	5	Mixing fan slot
3	Mixing fan cable	6	Mixing fan and housing

Illustration 1.3 Power Terminal Mounting Plate

1.4 Assembly Guidelines

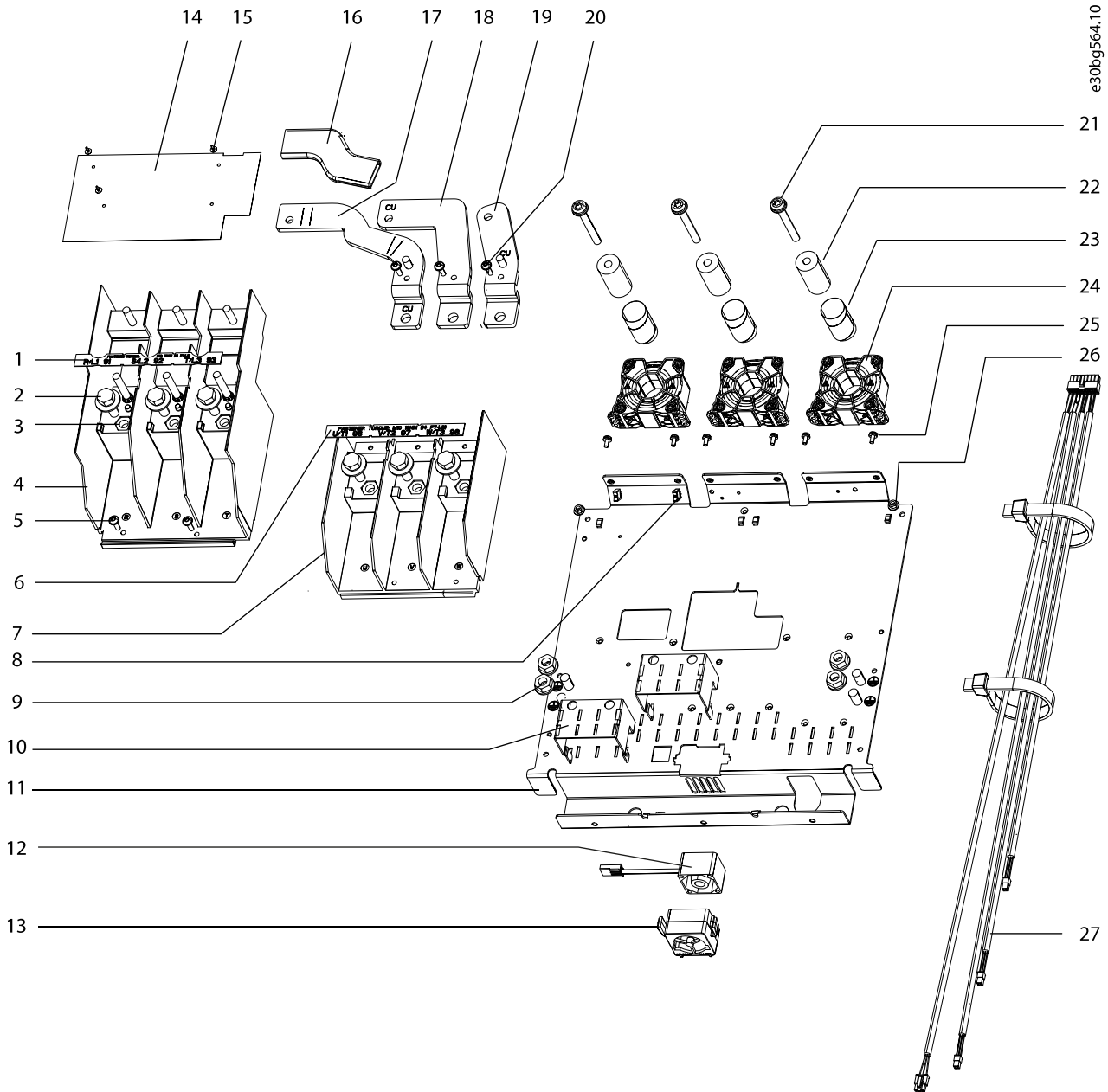

e30bg564.10

1	R/S/T terminal label	12	Mixing fan	23	Nomex tube
2	M10x30 machine screw	13	Mixing fan housing	24	Current sensor
3	M10 nut	14	EMC shield	25	M4x10 thread-forming screw
4	Mains input terminal block	15	Plastic mounting button	26	M5 nut
5	M5x12 machine screw	16	Busbar insulator sleeve	27	Wire harness (current sensor cables)
6	U/V/W terminal label	17	Motor busbar, U	-	Not shown: multiple wire guide, wire routing clip, M5x11 thread-cutting screw, power terminal mounting plate (IP20/Chassis), and IGBT busbars (in 300 A current sensor kit only).
7	Motor terminal block	18	Motor busbar, V		
8	Cable retaining clip	19	Motor busbar, W		
9	M10 nut with captive washer	20	M5x16 torx screw		
10	Cable clamp adapter	21	M8x70 screw		
11	Power terminal mounting plate (IP21/IP54)	22	Cylinder busbar		

Illustration 1.4 Exploded View of 500 A Current Sensor Kit

1.4.1 Installing Current Sensors

NOTICE

MOUNTING PLATE SELECTION

The kit includes 2 power terminal mounting plates, select the correct plate for the enclosure. *Illustration 1.4* shows the plate for IP20/Chassis enclosures. *Illustration 1.5* shows the plate for IP21/Type 1 and IP54/Type 12 enclosures.

1. Position 3 current sensors on top of the power terminal mounting plate so that the cable connectors face the back of the drive. Ensure that the airflow arrows on the sensors point toward the front of the drive.
2. Secure 6 M4x10 thread-forming screws (T20), 2 in the base of each current sensor. Torque to 2.0 Nm (17.7 in-lb).
3. Connect the wire harness to the current sensors, 1 cable to each current sensor.
4. Route the cables through the cable guides.

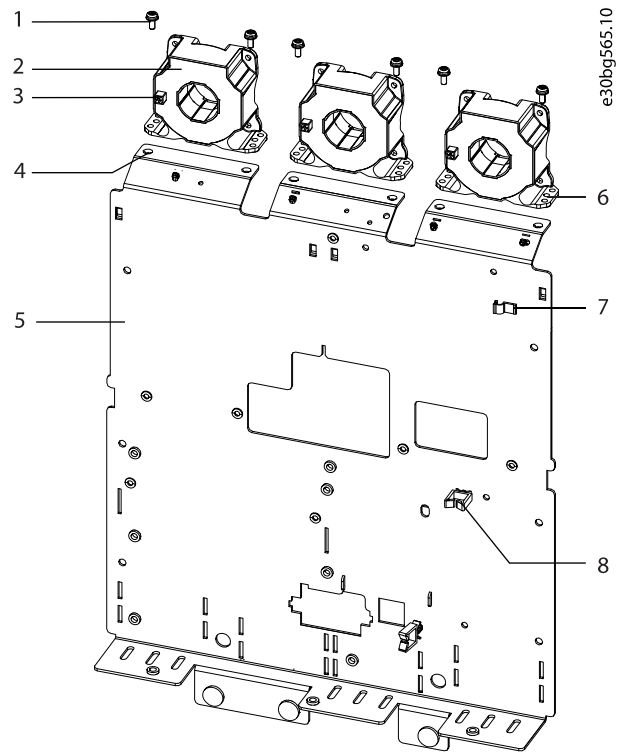

1	M4x10 thread-forming screw
2	Current sensor
3	Current sensor cable connector
4	Mounting hole
5	Power terminal mounting plate
6	Mounting hole
7	Wire guide
8	Cable clip

Illustration 1.5 Back View of Power Terminal Mounting Plate and Current Sensors

1.4.2 Installing Power Terminal Mounting Plate

To install the new power terminal mounting plate in the drive, use the following steps. Refer to *Illustration 1.4* and *Illustration 1.5*.

1. Position the power terminal mounting plate in the drive.
2. Fasten the plate with 7 M5x11 thread-cutting screws (T25).
3. Connect the wire harness to the MK100 connector on the power card.
4. Connect the fan cable to the mixing fan cable connector.
5. Insert the mixing fan into the fan housing, with the label facing the open side of the housing.
6. With the fan label facing up, insert the mixing fan assembly into the slot in the plate and press. The fan assembly is level with the plate when properly seated.
7. For the IP21/Type 1 and IP54/Type 12 enclosures only, fasten 4 ground nuts with captive washer (10 mm) in the power terminal mounting plate.
8. For IP20/Chassis enclosures only, fasten 3 nuts (8 mm) at the bottom of the plate.

1.4.3 Installing Motor Terminal Block

To install the motor terminal block, use the following steps. Refer to *Illustration 1.4*.

1. Position the output terminal block by sliding it upward under the 2 metal retaining clips on the power terminal mounting plate.
2. Fasten 2 M5x12 machine screws (T25) at the bottom of the terminal block.
3. Position the 3 Nomex tubes, 1 in the middle of each current sensor.
4. Insert 3 cylinder busbars, 1 inside each Nomex tube.
5. Replace the U motor busbar:
 - 5a Slide the insulator sleeve over the U busbar.
 - 5b Fasten 1 screw (T30) in the current sensor end of the busbar.
 - 5c Fasten 1 thread-forming screw (T25) in the middle of the busbar.
6. Replace the V motor busbar:

6a Fasten 1 screw (T30) in the current sensor end of the busbar.

6b Fasten 1 thread-forming screw (T25) in the middle of the busbar.

7. Replace the W motor busbar:

7a Fasten 1 screw (T30) in the current sensor end of the busbar.

7b Fasten 1 thread-forming screw (T25) in the middle of the busbar.

8. Position the EMC shield between the mains input terminal block and motor terminal block and secure with 1 screw (T25).

9. Reconnect wiring to the motor terminals, and replace the U/V/W terminal label.

1.4.4 Installing Brake Terminals (Optional)

To replace the optional brake terminals, if any, use the following steps.

1. Install the brake terminal block by fastening 2 nuts (13 mm) in the block.
2. Install the R (-) terminal:
 - 2a Fasten 1 thread-forming screw (T25) at the terminal block.
 - 2b Fasten 1 additional nut (13 mm).
3. Install the R (+) terminal:
 - 3a Fasten 1 thread-forming screw (T25) at the terminal block.
 - 3b Fasten 1 additional screw (T40).

1.4.5 Installing Mains Input Terminal Block

1. Position the mains input terminal block on the power terminal mounting plate and slide it upward under 2 metal retaining clips.
2. Fasten 2 screws (T25) at the bottom of the mains input terminal block.
3. Route the current sensor wiring through the cable retaining clips.
4. Place the R/S/T terminal label above the terminal connections.

1.4.6 Installing AC Input Busbars

To install the AC input busbars, use the following steps. The AC input busbars can look different when the drive includes extra input options, such as an RFI filter or mains fuses.

Illustration 1.2 shows the AC input busbars configured to include mains fuses.

1. The next step differs based on the input options present in the drive. Select the appropriate procedure for the drive:
 - No options
 - Mains fuses only
 - RFI filter only
 - Mains fuses and RFI filter

No options

1. Position the 3 AC input busbars in the drive.
2. Secure 3 nuts (13 mm), 1 in the top of each AC input busbar.
3. Fasten 3 nuts (13 mm), 1 in the bottom of each AC input busbar.
4. Connect the customer mains input power wiring.
5. Replace the air baffle and secure with 4 screws (T25) and 2 nuts (13 mm).

Mains fuses only

1. Position the 3 AC input busbars in the drive.
2. Secure 3 nuts (13 mm), 1 in the top of each AC input busbar.
3. Install the 3 mains fuses by securing 6 nuts (13 mm), 1 at each end of the fuses.
4. Connect the customer mains input power wiring.
5. Replace the air baffle and secure with 4 screws (T25) and 2 nuts (13 mm).

RFI filter only

1. Connect the RFI cable to MK100 on the RFI printed circuit card.
2. Fasten the RFI filter to the side channels of the drive with 4 thread-cutting screws (T20).
3. Secure the top of the RFI filter using 3 nuts (13 mm), 1 per phase.
4. Secure the bottom of the RFI filter using 6 nuts (13 mm), 2 per phase.
5. Connect the customer mains input power wiring.
6. Replace the air baffle and secure with 4 screws (T25) and 2 nuts (13 mm).

Mains fuses and RFI filter

1. Connect the RFI cable to MK100 on the RFI printed circuit card.
2. Fasten the RFI filter to the side channels of the drive with 4 thread-cutting screws (T20).
3. Secure the top of the RFI filter using 3 nuts (13 mm), 1 per phase.
4. Install 3 mains fuses using 6 nuts (13 mm), 1 at each end of the fuses.
5. Connect the customer mains input power wiring.
6. Replace the air baffle and secure with 4 screws (T25) and 2 nuts (13 mm).

.....
Danfoss can accept no responsibility for possible errors in catalogues, brochures and other printed material. Danfoss reserves the right to alter its products without notice. This also applies to products already on order provided that such alterations can be made without subsequential changes being necessary in specifications already agreed. All trademarks in this material are property of the respective companies. Danfoss and the Danfoss logotype are trademarks of Danfoss A/S. All rights reserved.
.....

Danfoss A/S
Ulsnaes 1
DK-6300 Graasten
vlt-drives.danfoss.com

