

Installation Instructions

500 A Current Sensor Kit for E1/E2 Enclosure Sizes

VLT® FC 102, FC 103, FC 202, FC 302

1.1.1 Description

The 500 A current sensor kit is designed for E1 and E2 enclosure sizes in the power ranges shown in *Table 1.1*. To identify the power rating, see *Illustration 1.1*.

Product group and series	Voltage rating	Power rating
VLT® HVAC Drive FC 102, VLT® Refrigeration Drive FC 103, VLT® AQUA Drive FC 202	(T4/T5) 380–480 V (T7) 525–690 V	315 kW (450 hp) 450–560 kW (450–600 hp)
VLT® AutomationDrive FC 302	(T5) 380–500 V (T7) 525–690 V	250 kW (450 hp) 355–500 kW (450–600 hp)

Table 1.1 Applicable Power Range for 500 A Current Sensor Kit

The 500 A current sensor kit contains all components required to upgrade the current sensors in E1 and E2 enclosure sizes.

1.1.2 Identifying the Power Rating

To find the frequency converter power rating, use the following steps.

1. Obtain the following information from the nameplate, which is on the frequency converter. Refer to *Illustration 1.1*.
 - 1a Product group and product series (characters 1–6)
 - 1b Power rating (characters 7–10)
 - 1c Voltage rating (phases and mains) (characters 11–12)
2. Determine if the power rating is in *Table 1.1*.

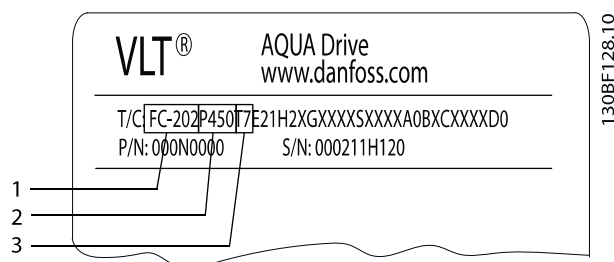

1	Product group and product series
2	Power rating
3	Voltage rating (phases and mains)

Illustration 1.1 Nameplate Information for a Frequency Converter

1.2 Kit Part Number

Part number	Kit description
176F3746	500 A Current sensor kit for E1/E2 enclosure sizes

Table 1.2 Part Number for the Current Sensor Kit

1.2.1 Items Supplied

The 500 A Current Sensor Kit for E1 and E2 enclosure sizes contains the following parts.

Quantity	Item description
3	500 A current sensor and busbar
3	Current sensor bracket
1	Wire harness and cable ties
12	Hex nuts (M4) and washers

Table 1.3 500 A Current Sensor Kit Parts List

1.3 Safety Instructions

CAUTION

TRAINING REQUIRED

Only certified technicians trained by Danfoss are allowed to replace the parts described in these installation instructions. Installation work done by non-qualified personnel can result in personal injury or equipment damage. Make sure to read and save these instructions.

WARNING

ELECTRICAL SHOCK HAZARD

VLT[®] frequency converters contain dangerous voltages when connected to mains voltage. Improper installation, and installing or servicing with power connected can cause death, serious injury, or equipment failure.

To avoid death, serious injury, or equipment failure:

- Only use qualified electricians for the installation.
- Disconnect the frequency converter from all power sources before installation or service.
- Treat the frequency converter as live whenever the mains voltage is connected.
- Follow the guidelines in these instructions and local electrical safety codes.

WARNING

DISCHARGE TIME

The frequency converter contains DC-link capacitors, which can remain charged even when the unit is off. High voltage can be present even when the warning indicator lights are off. Failure to wait a minimum of 20 minutes after power is removed before performing service work can result in death or serious injury.

1. Stop the motor.
2. Disconnect AC mains and remote DC-link supplies, including battery back-ups, UPS, and DC-link connections to other frequency converters.
3. Disconnect or lock PM motor.
4. Wait 20 minutes for the capacitors to discharge.
5. To verify full discharge, measure the voltage level.

1.4 Disassembly Guidelines

NOTICE

The current sensor kit includes an extra set of fasteners in case any fasteners are missing or unusable. To make the disassembly/reassembly process easier, use these general guidelines:

1. Follow the disassembly instructions for each component.
2. Place the component along with the removed fasteners together in one place.
3. Replace old component with the new component provided in the kit.
4. If any fasteners are stripped or lost, replace with similar fastener from the kit.
5. Follow the installation instructions for replacing and securing each component.

1.4.1 Removing the Input Terminal Plate

To remove the input terminal plate, use the following procedure. Refer to *Illustration 1.2* and *Illustration 1.3*.

Optional components mounted on the input terminal plate can result in differing configurations. These options include:

- Input disconnect.
- RFI filter.
- AC fuses with cooling fan.

1. Disconnect the input power wiring from terminals R (L1), S (L2), T (L3), and ground connector.
2. Remove the uppermost retaining nut (M10) from each of the 3 input busbars.
3. If a disconnect option (not shown) is present, remove the disconnect from the terminal plate assembly to reduce the weight of the terminal plate as follows:
 - 3a Loosen the connection nut (17 mm) between each fuse and the disconnect.
 - 3b Remove the 4 mounting screws (T40) from the disconnect.
 - 3c Slide the disconnect down to clear the fuses and remove it.
4. If the fuse option with cooling fan is present, disconnect the cooling fan cable from the connector.
5. If the RFI filter option is present, disconnect the RFI cable from the connector.
6. Remove the 8 retaining nuts (M6) from the input terminal plate.
7. Lift the input terminal plate with attached input busbars and options from the unit.

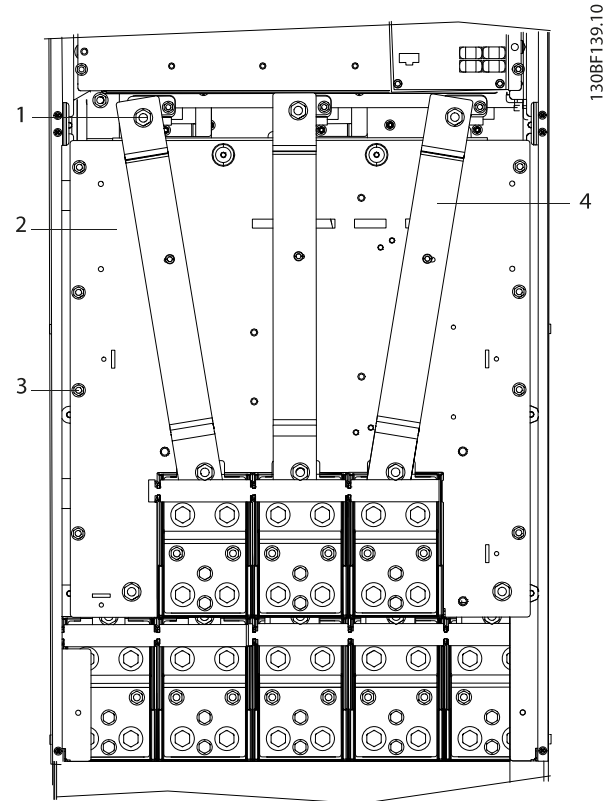

1	Upper retaining nut (M10)
2	Input terminal plate
3	Mounting plate retaining nut (M6)
4	Input busbars

Illustration 1.2 Input Terminal Plate

NOTICE

The terminal plate and attached options weigh up to 20 kg (44 lb).

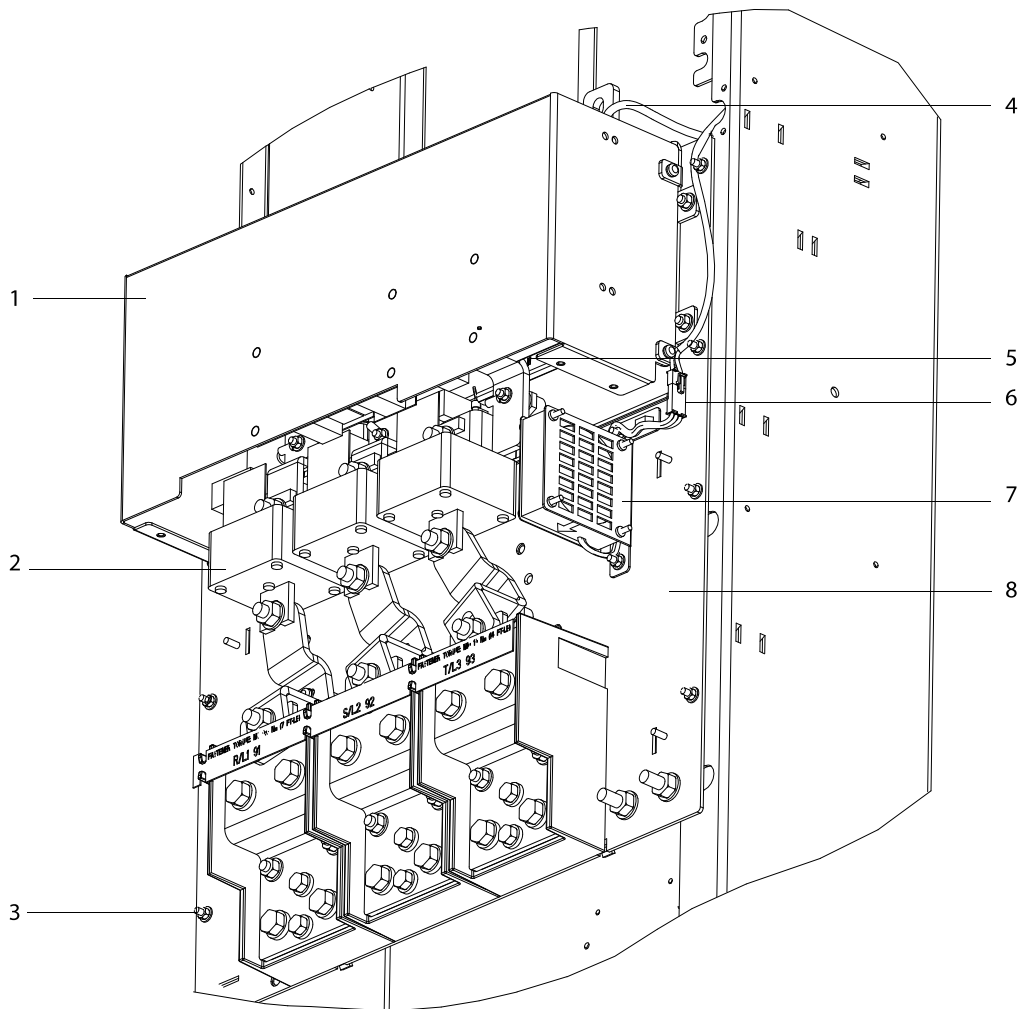

130BF124.10

1	RFI filter (optional)	5	RFI cable connector
2	AC fuse (optional)	6	Cooling fan cable connector
3	Retaining nut (M6)	7	Cooling fan (optional)
4	RFI cable	8	Input terminal plate

Illustration 1.3 Input Terminal Plate (with RFI Filter and Fuse Options)

1.4.2 Removing the IGBT Output Busbars

To remove the IGBT output busbars, use the following procedure. Refer to *Illustration 1.4*.

1. Remove 3 retaining screws (M10), 1 from the lower end of each of the 3 IGBT output busbars.
2. Remove 3 retaining nuts (M10), 1 from the upper end of each of the 3 IGBT output busbars.
3. Lift the 3 busbars from the unit.

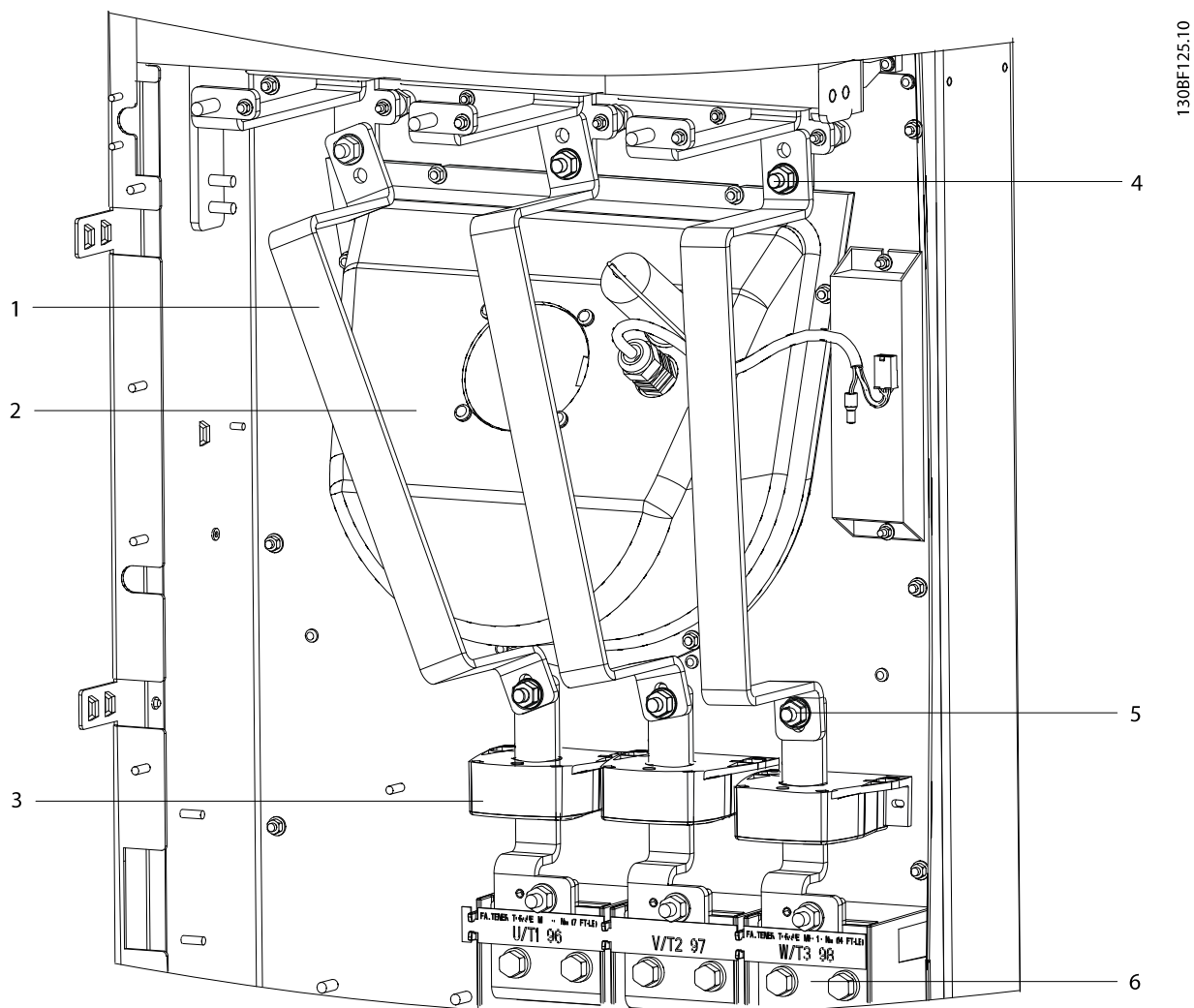

1	IGBT output busbar	4	Upper retaining nut (M10)
2	Fan housing	5	Lower retaining screw (M10)
3	Current sensor	6	Output terminal

Illustration 1.4 IGBT Output Busbars

1.4.3 Removing the Upper Capacitor Bank

To remove the upper capacitor bank assembly, use the following procedure. Refer to *Illustration 1.5*.

NOTICE

The capacitor bank assembly weighs approximately 9 kg (20 lb).

1. Disconnect the IGBT wire harness from the following connectors on the gatedrive card:
 - 1a MK100
 - 1b MK101 (if RFI filter option is present)
 - 1c MK102
 - 1d MK103
 - 1e MK104
 - 1f MK105 (if brake option is present)
 - 1g MK106
2. The capacitor bank connections to the DC busbars are recessed in the gap between the upper and lower capacitor banks. A minimum extension of 150 mm (6 in) is required. Remove the 6 nuts (M5) connecting the upper capacitor bank to the DC busbars.
3. Remove the 4 retaining nuts (M6), 1 from each corner of the upper capacitor bank.
4. Lift the upper capacitor bank assembly from the unit. The gatedrive card can remain in place on the assembly.

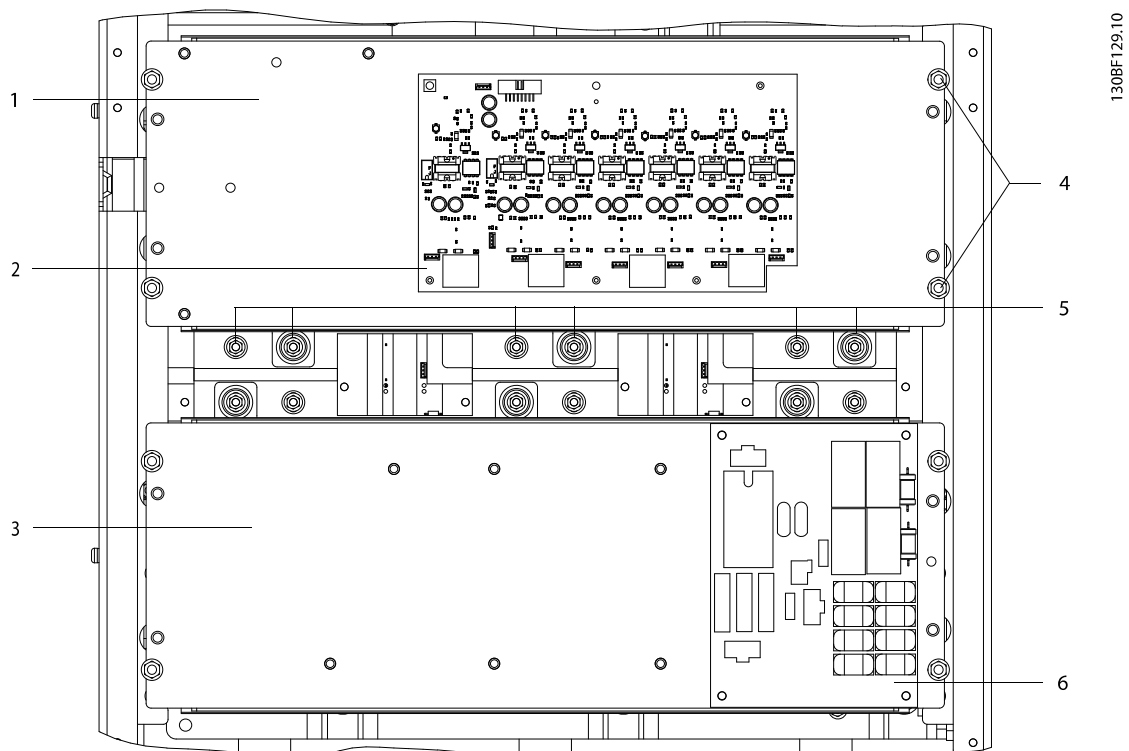

1	Upper capacitor bank	4	Retaining nuts (M6)
2	Gatedrive card	5	Recessed connection nuts (M5)
3	Lower capacitor bank	6	Soft charge card

Illustration 1.5 Upper and Lower Capacitor Bank Assemblies

1.4.4 Removing the Current Sensor Wire Harness

Remove the current sensor wire harness using the following procedure. Refer to *Illustration 1.6*.

1. Disconnect the following items from the power card:
 - 1a Unplug the 16-pin cable from the MK102 connector.
 - 1b Detach the heat sink cable from its 3-pin connector.
 - 1c Remove the screw (M5) attaching the ring terminal ground.
2. Detach the opposite end of the heat sink cable.
3. Detach the cable from the 3-pin connector on the high-frequency card.
4. Disconnect the wires from each of the 3 current sensors.
5. Detach any cable ties that secure the wire harness in the unit.
6. Remove the current sensor wire harness from the unit.

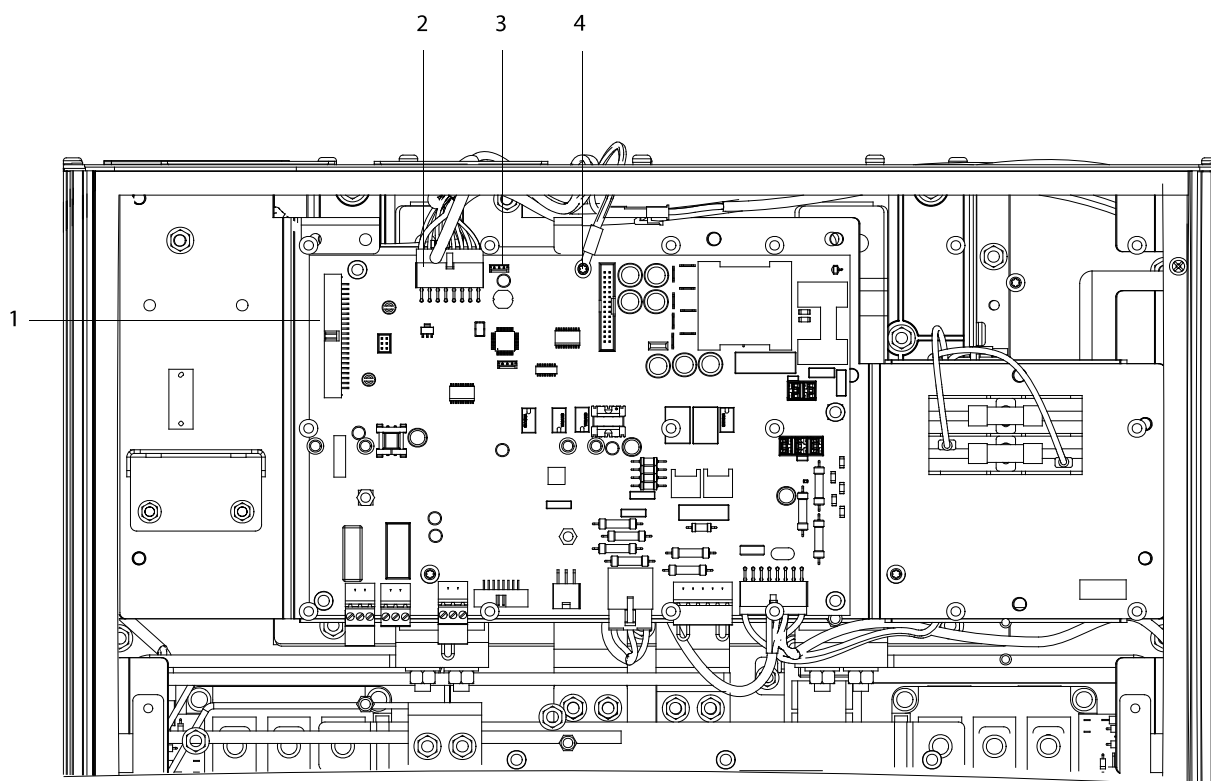

1308F300.10

1	Power card	3	Heat sink cable 3-pin connector
2	16-pin cable connector (MK102)	4	Ring terminal ground (M5)

Illustration 1.6 Power Card

1.4.5 Removing Current Sensors and Busbars

Remove the current sensor and busbars using the following procedure. Refer to *Illustration 1.7*.

1. Remove the terminal label.
2. Remove the 3 retaining nuts (M10), 1 from each output terminal busbar.
3. Remove the 6 screws (M4) that connect the current sensors to the base plate, 2 from each sensor.
4. Lift the 3 current sensors and busbars from the unit.

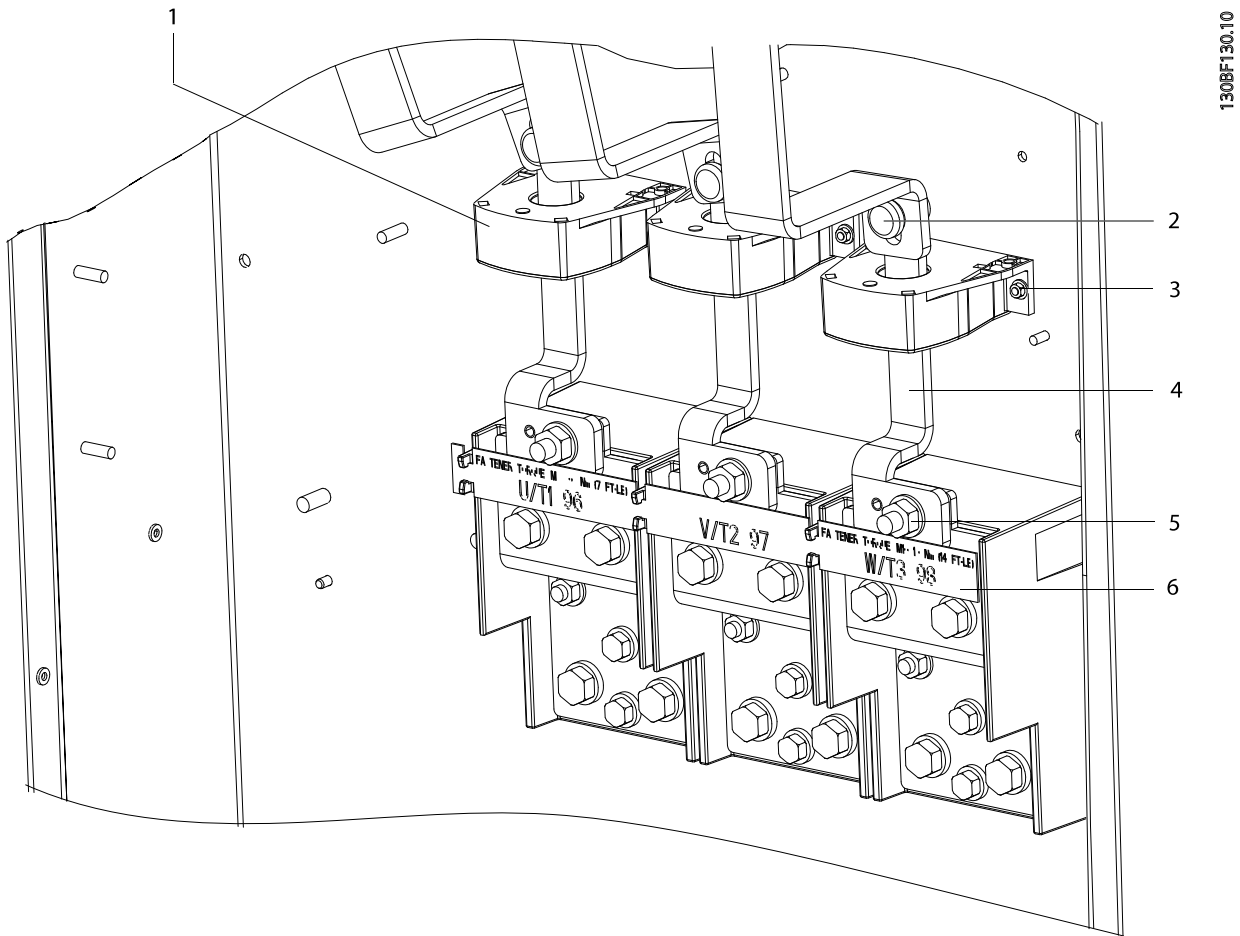

1	Current sensor	4	Output terminal busbar
2	IGBT busbar retaining nut	5	Output terminal busbar retaining nut (M10)
3	Current sensor base plate screw (M4)	6	Terminal label

Illustration 1.7 Current Sensors and Busbars

1.5 Reassembly Guidelines

1.5.1 Installing Current Sensors and Busbars

Install the current sensors and busbars using the following steps.

1. Secure the current sensor brackets to the terminal mounting plate with 6 nuts (M4), 2 in each bracket.
2. Position the 3 current sensors with the arrow on each sensor facing away from the fan housing. See *Illustration 1.8*.
3. Secure the 6 screws (M4) that connect the current sensors to the brackets, 2 in the base of each sensor.
4. Secure the 3 retaining nuts (M10), 1 in the base of each output terminal busbar.
5. Place the terminal label back in its original position.

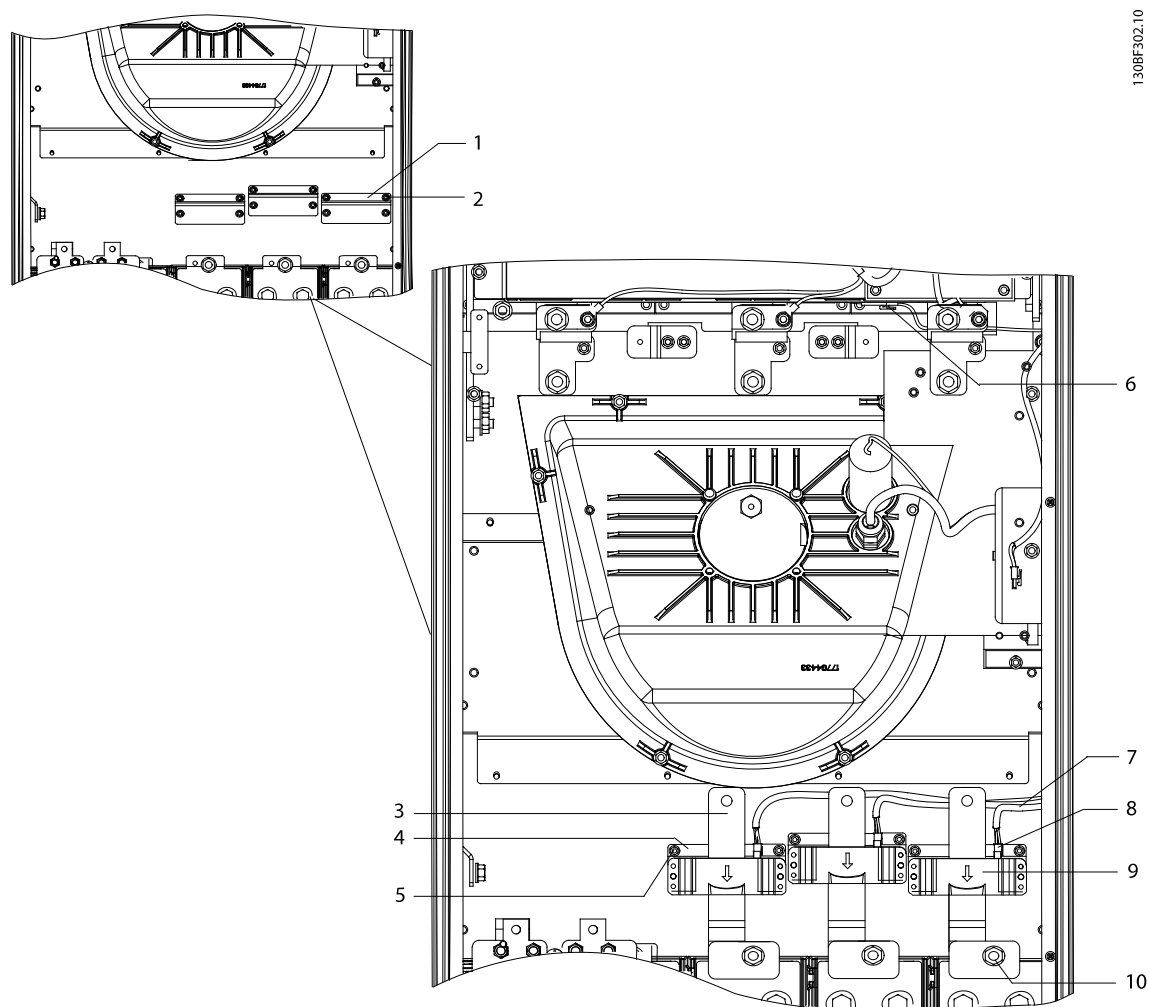

1	Current sensor bracket	6	Heat sink cable connector
2	Nut (M4)	7	Current sensor cables
3	Output terminal busbar	8	Current sensor cable connector
4	Current sensor bracket	9	Current sensor
5	Nut (M4)	10	Output terminal busbar retaining nut (M10)

Illustration 1.8 Current Sensors and Busbars

1.5.2 Installing the Current Sensor Wire Harness

Install the new current sensor wire harness using the following procedure. Refer to *Illustration 1.8*.

1. Connect the following items to the power card:
 - 1a Plug the 16-pin cable into MK102.
 - 1b Attach the heat sink cable to 3-pin connector.
 - 1c Secure the screw (M5) attaching the ring terminal ground.
2. Connect the other end of the heat sink cable.
3. Attach the cable to the 3-pin connector on the high-frequency card.
4. Plug a cable into each of the 3 current sensors.
5. Secure the wire harness with the cable ties.

1.5.3 Installing the Upper Capacitor Bank

Reinstall the upper capacitor bank assembly using the following procedure. Refer to *Illustration 1.5*.

NOTICE

The upper capacitor bank weighs approximately 9 kg (20 lb).

1. Place the upper capacitor bank assembly in its original position in the unit.
2. The capacitor bank connection to the DC busbars is recessed in the gap between the upper and lower capacitor banks. A minimum extension of 150 mm (6 in) is required. Secure the 6 connection nuts (M5) to the capacitor bank.
3. Secure 4 retaining nuts (M6), 1 in each corner of the upper capacitor bank assembly.
4. Connect the IGBT wire harness to the following connectors on the gatedrive card.
 - 4a MK100 (NTC)
 - 4b MK101 (if RFI filter option is present)
 - 4c MK102 (U)
 - 4d MK103 (V)
 - 4e MK104 (W)
 - 4f MK105 (if brake option is present)
 - 4g MK106

1.5.4 Installing the IGBT Output Busbars

Reinstall the IGBT output busbars using the following procedure. Refer to *Illustration 1.4*

1. Place 3 busbars in position over the fan housing.
2. Secure 3 retaining nuts (M10), 1 at the upper end of each of the 3 IGBT output busbars.
3. Secure 3 retaining screws (M10), 1 at the lower end of each of the 3 IGBT output busbars.

1.5.5 Installing the Input Terminal Mounting Plate

Reinstall the input terminal plate and busbars using the following steps. See *Illustration 1.2* and *Illustration 1.3*. Optional components mounted on the input terminal plate can result in differing configurations. These options include:

- Input disconnect.
- RFI filter.
- AC fuses with cooling fan.

NOTICE

The terminal plate and options weigh up to 20 kg (44 lb).

1. Place the input terminal plate in its original position.
2. Secure the input terminal plate with 8 retaining nuts (M6).
3. If a disconnect option is present, reattach to the terminal plate assembly as follows:
 - 3a Slide on the disconnect to clear the fuses and place it in position.
 - 3b Secure the 4 mounting screws (T40).
 - 3c Tighten the connection nut (17 mm) between each fuse and the disconnect.
4. If an RFI filter option is present, reconnect the cable.
5. If a fuse option with cooling fan is present, connect the cooling fan cable.
6. Secure the uppermost retaining nut (M10) on each of the 3 input busbars.
7. Connect input power wiring to terminals R (L1), S (L2), T (L3), and ground.

Danfoss can accept no responsibility for possible errors in catalogues, brochures and other printed material. Danfoss reserves the right to alter its products without notice. This also applies to products already on order provided that such alterations can be made without consequential changes being necessary in specifications already agreed. All trademarks in this material are property of the respective companies. Danfoss and the Danfoss logotype are trademarks of Danfoss A/S. All rights reserved.

