

VACON[®] NXP
AC DRIVES

IPOO MODULES
FRAMES FR9 TO FR14
INSTALLATION QUICK GUIDE

VACON[®]

TABLE OF CONTENTS

Document: DPD00889B

Release date : 28.02.2019

1.	Delivered modules / installing AC chokes and power module	4
1.1	Products included in the delivery	4
1.2	Lifting the power module	4
1.3	Installing the power module	5
2.	Ventilation.....	6
2.1	Steering the internal air flow	6
2.2	Arranging ventilation of the enclosure	7
3.	Grounding and cabling the unit	8
3.1	Connecting the internal power cable.....	8
3.2	Installing the optical fibers	9
3.3	Installing the motor cable.....	9

1. DELIVERED MODULES / INSTALLING AC CHOKES AND POWER MODULE

1.1 PRODUCTS INCLUDED IN THE DELIVERY

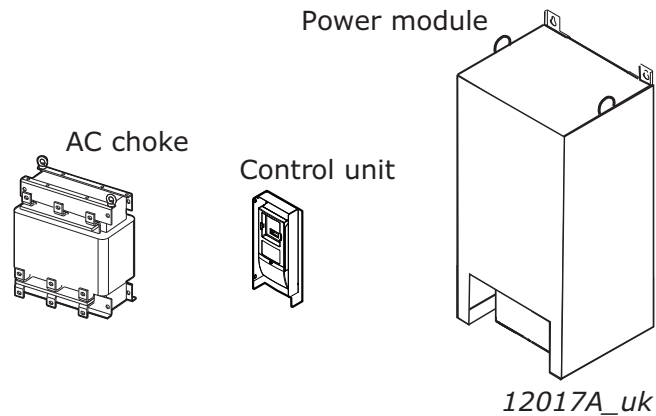

NOTE! FR12 = 2 x FR10; F14 = 2 x F13 power modules.

NOTE! In FR9, the AC choke is inside the power module.

1.2 LIFTING THE POWER MODULE

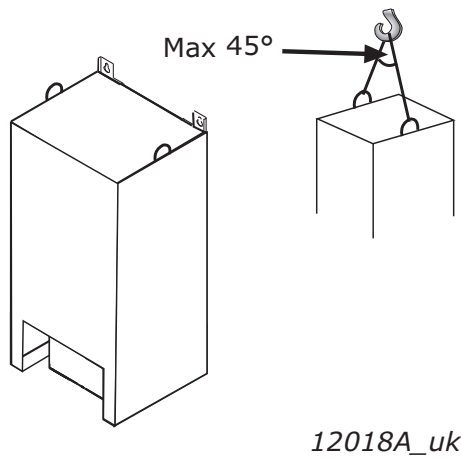

Frame	Weight kg
FR9	146
FR10	123
FR11	210
FI9	65
FI10	100
FI12	200
FI13	302

NOTE! Place the lifting hooks symmetrically in at least two holes. The lifting devices must be able to carry the weight of the module.

NOTE! The maximum allowed lifting angle is 45°.

1.3 INSTALLING THE POWER MODULE

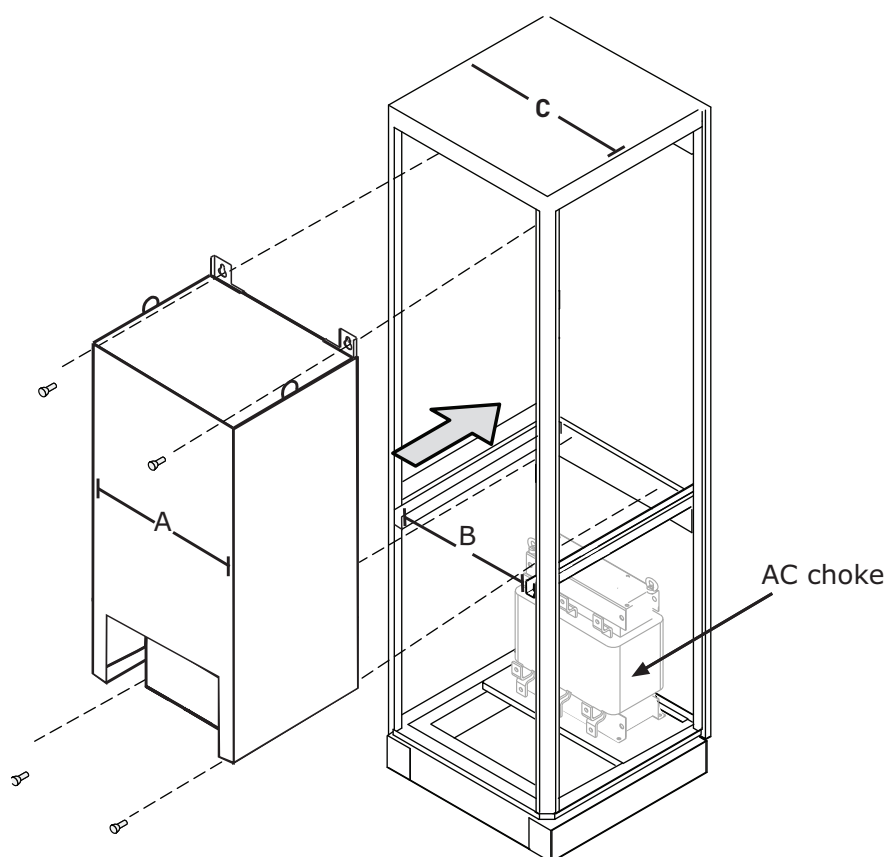

12019A_uk

Frame	Device width A/mm	Supporting bar range B/mm	Recommended cabinet width C/mm
FR9	480	A - 50 mm	600
FR10	500	A - 50 mm	600
FR11	709	A - 20 mm	800
FI9	239	A - 50 mm	400
FI10	239	A - 50 mm	400
FI12	478	A - 50 mm	600
FI13	708	A - 50 mm	800

NOTE! For detailed drawing, see manual.

2. VENTILATION

2.1 STEERING THE INTERNAL AIR FLOW

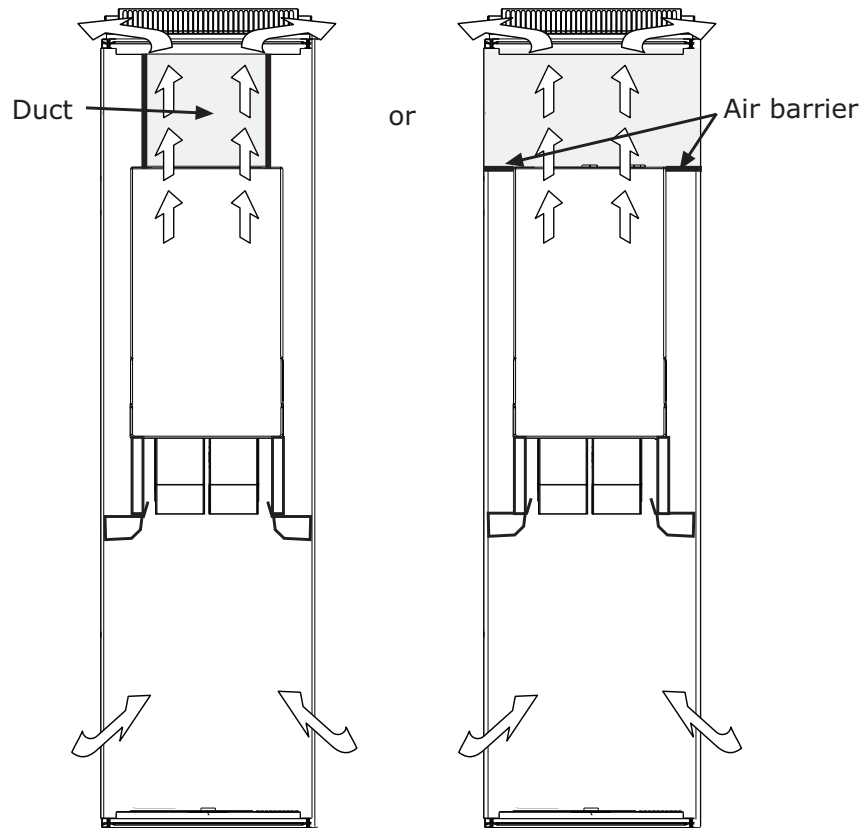

12022A_uk

NOTE! Outgoing air must be directed out of the cabinet so that it does not mix with incoming cooling air.

2.2 ARRANGING VENTILATION OF THE ENCLOSURE

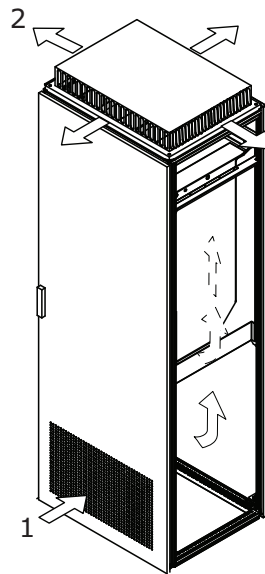

12023A_00

CAUTION! It is of utmost importance for the operation and lifetime of the frequency converter that the closure is well ventilated to keep the temperature below the maximum operating temperature. Repeated overheating will shorten the lifetime of the converter.

Table 1. Ventilation requirements table

Frame	Cooling air required m ³ /h	Minimum air hole on switchgear/dm ²	
		1) Inlet	2) Outlet
FR9	1300	9.1	7
FR10	2000	9.5	5
FR11	3000	14	7.5
FI9	1150	5.5	3
FI10	1400	6.5	4
FI12	2800	13	7
FI13	4200	19.5	10.5

3. GROUNDING AND CABLING THE UNIT

3.1 CONNECTING THE INTERNAL POWER CABLE

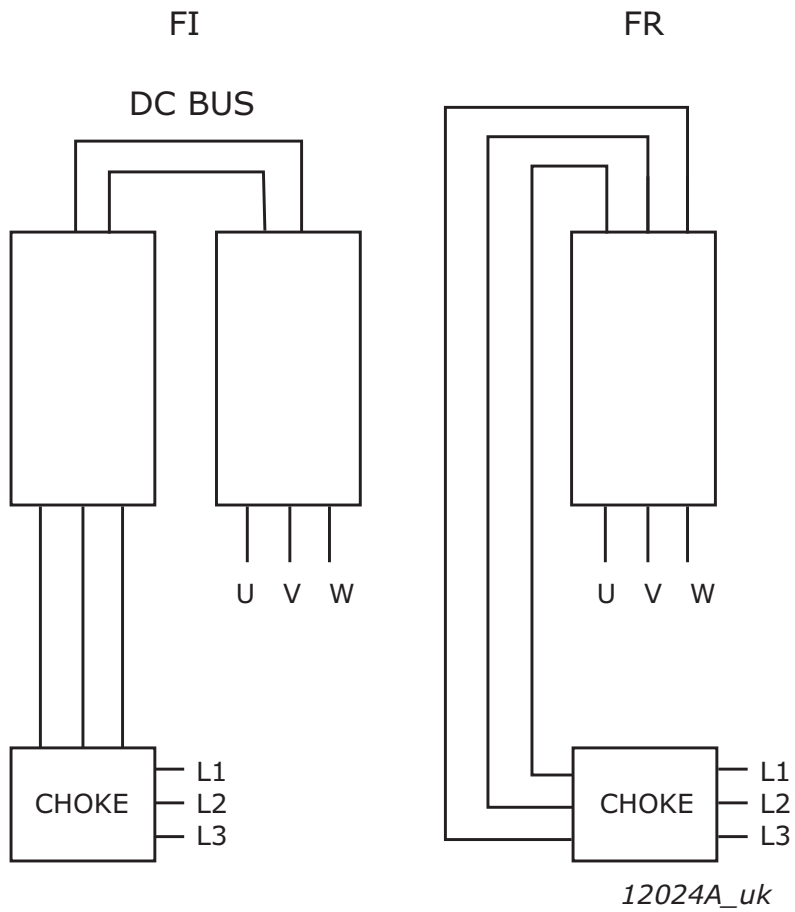

See IP00 Module Installation Manual for details.

NOTE! No external choke in FR9.

3.2 INSTALLING THE OPTICAL FIBERS

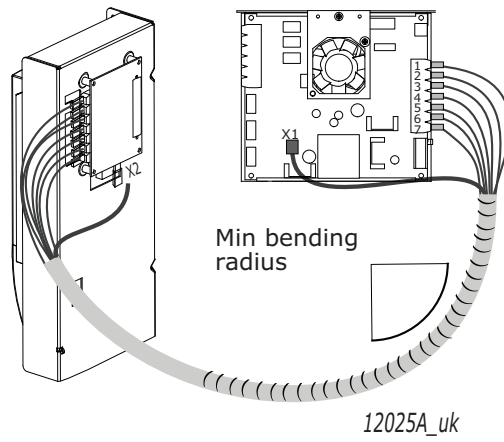

3.3 INSTALLING THE MOTOR CABLE

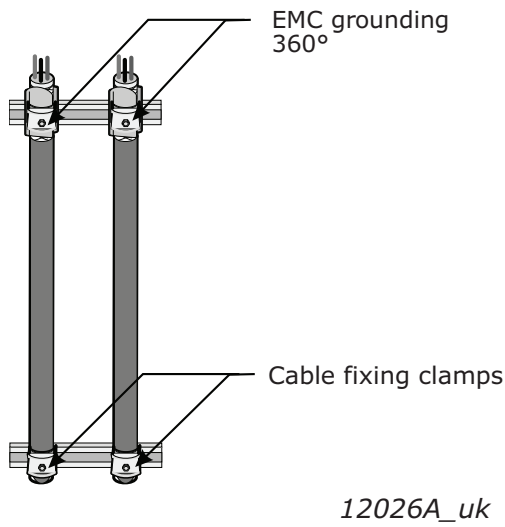

VACON[®]

www.danfoss.com

Vacon Ltd
Member of the Danfoss Group
Runsorintie 7
65380 Vaasa
Finland

Document ID:



DPD00889B

Rev. B