

Data sheet

# APP S pumps

## APP S 2.0-3.5 / APP S 5.1-9.0 / APP S 21-38



**Table of Contents**

|       |                                                                       |    |
|-------|-----------------------------------------------------------------------|----|
| 1.    | Introduction .....                                                    | 3  |
| 2.    | Benefits.....                                                         | 3  |
| 3.    | Application areas .....                                               | 3  |
| 4.    | Technical data .....                                                  | 4  |
| 4.1   | APP S 2.0-3.5.....                                                    | 4  |
| 4.2   | APP S 5.1-9.0 .....                                                   | 5  |
| 4.3   | APP S 21-38 .....                                                     | 6  |
| 5.    | Flow .....                                                            | 7  |
| 5.1   | APP S 2.0-3.5 flow curves at max. pressure .....                      | 7  |
| 5.2   | APP S 5.1-9.0 flow curves at max. pressure.....                       | 8  |
| 5.3   | APP S 21-38 flow curves at max. pressure .....                        | 9  |
| 5.4   | Flushing valve characteristics.....                                   | 10 |
| 5.4.1 | APP S 2.0-3.5 integrated flushing valve curve .....                   | 10 |
| 5.4.2 | APP S 5.1-9.0 integrated flushing valve curve.....                    | 10 |
| 5.4.3 | APP S 21-38 integrated flushing valve curve.....                      | 10 |
| 6.    | Corrosion .....                                                       | 11 |
| 7.    | Motor requirements.....                                               | 11 |
| 8.    | Installation.....                                                     | 12 |
| 8.1   | Filtration.....                                                       | 12 |
| 8.2   | Noise .....                                                           | 12 |
| 8.2.1 | APP S 2.0-3.5 pump mounted on motor 5.5 kW 4-pole / 11 kW 2-pole..... | 13 |
| 8.2.2 | APP S 5.1-9.0 pump mounted on motor 22 kW 4-pole .....                | 13 |
| 8.2.3 | APP S 21-38 pump mounted on motor 75 kW 4-pole .....                  | 13 |
| 8.3   | Open system design .....                                              | 14 |
| 8.4   | RO system with APP S pump.....                                        | 14 |
| 9.    | Dimensions and connections .....                                      | 15 |
| 9.1   | APP S 2.0-3.5.....                                                    | 15 |
| 9.2   | APP S 5.1-9.0 .....                                                   | 16 |
| 9.3   | APP S 21-38 .....                                                     | 17 |
| 10.   | Service.....                                                          | 18 |
| 10.1  | Warranty.....                                                         | 18 |
| 10.2  | Maintenance.....                                                      | 18 |

1. Introduction

The APP S pump is designed to supply low viscosity and corrosive fluids under high pressure, e.g. in seawater reverse osmosis applications.

Danfoss APP S pumps are positive displacement pumps, with axial pistons, that move a fixed amount of water in each cycle. Flow is proportional to the number of pump shaft revolutions (rpm). Unlike centrifugal pumps, they produce the same flow at a given speed no matter what the discharge pressure.

The pumps are supplied with an integrated flushing valve that allows the saltwater to flow from inlet to the outlet, when the pump is not running.

The pumps are made for flange connections.

All parts included in the pumps are designed to provide long service life, i.e. long service life with a constantly high efficiency and minimum service required.

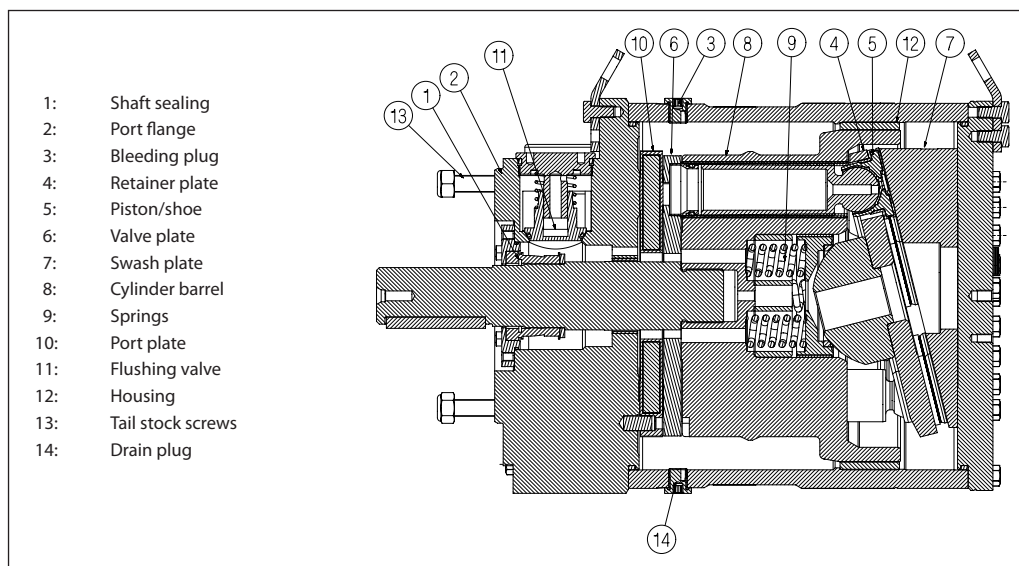

2. Benefits

- **Zero risk of lubricant contamination:**  
Oil lubricants are replaced with the pumped medium, seawater or brackish water, so SWRO and BWRO applications are completely free of any contamination risk from the pump.
- **Low maintenance costs:**  
Efficient design and all Super Duplex stainless steel construction ensure exceptionally long life. When Danfoss specifications are met, service intervals up to 8,000 hours can be expected.
- **Low energy costs:**  
The highly efficient axial piston design provides the lowest power consumption of any comparable pump on the market.
- **Easy configuration:**
  - The lightest and most compact design available. Pump can be installed vertically and horizontally.
  - No pulsation dampeners necessary due to extremely "low pressure" pulsation.
  - Powered direct by electric motor or combustion engine.
  - Pump can be delivered with all types of flange connections.
- **Certified quality:**  
Super Duplex stainless steel M 630 from NORSOK M 650 certified foundries.
  - Full traceability and material certificates on pressure containing parts.
  - Pump available as ATEX certified, category 2, zone 1 or category 3, zone 2.

3. Application areas

The pumps are used in RO systems for production of fresh water. This water can be used for drinking or as technical water used for NOx reduction in gas turbines or as water used for injection into wells.

APP S pumps are not only applicable for offshore applications but can also be used for applications which require traceability and material certificates.

As the APP S pumps are made in Super Duplex stainless steel, it makes them suitable for rough offshore applications. Apart from that the small and compact pumps are a perfect choice for applications where component size really matters.

**4. Technical data**
**4.1 APP S 2.0-3.5**

| Pumps size                                     |                       | APP S 2.0 | APP S 2.5 | APP S 3.0 | APP S 3.5 |
|------------------------------------------------|-----------------------|-----------|-----------|-----------|-----------|
| Code number                                    |                       | 180B7063  | 180B7064  | 180B7085  | 180B7086  |
| Geometric displacement                         | cm <sup>3</sup> /rev. | 12.1      | 15.3      | 17.7      | 20.5      |
|                                                | in <sup>3</sup> /rev. | 0.74      | 0.94      | 1.08      | 1.25      |
| <b>Pressure</b>                                |                       |           |           |           |           |
| Outlet min. pressure, continuous <sup>1)</sup> | barg                  | 20        | 20        | 20        | 20        |
|                                                | psig                  | 290       | 290       | 290       | 290       |
| Outlet max. pressure, continuous <sup>1)</sup> | barg                  | 80        | 80        | 80        | 80        |
|                                                | psig                  | 1160      | 1160      | 1160      | 1160      |
| Inlet operating pressure <sup>2)</sup>         | barg                  | 0.5-10    | 0.5-10    | 0.5-10    | 0.5-10    |
|                                                | psig                  | 7.25-145  | 7.25-145  | 7.25-145  | 7.25-145  |
| <b>Speed</b>                                   |                       |           |           |           |           |
| Min. speed, continuous                         | rpm                   | 700       | 700       | 700       | 700       |
| Max. speed, continuous <sup>3)</sup>           | rpm                   | 3000      | 3000      | 3000      | 3000      |
| <b>Typical Flow</b>                            |                       |           |           |           |           |
| 1500 rpm at max. pressure                      | m <sup>3</sup> /h     | 1.0       | 1.2       | 1.5       | 1.75      |
| 3000 rpm at max. pressure                      | m <sup>3</sup> /h     | 2.0       | 2.5       | 3.0       | 3.5       |
| 1800 rpm at max. pressure                      | gpm                   | 5.2       | 6.6       | 7.9       | 9.3       |
| 3000 rpm at max. pressure                      | gpm                   | 8.8       | 11.0      | 13.3      | 15.4      |
| <b>Typical motor size</b>                      |                       |           |           |           |           |
| 1500 rpm at max. pressure                      | kW                    | 3.0       | 4.0       | 4.0       | 5.5       |
| 1800 rpm at max. pressure                      | hp                    | 5.0       | 7.5       | 7.5       | 7.5       |
| <b>Torque at max. outlet pressure</b>          |                       |           |           |           |           |
|                                                | Nm                    | 19.1      | 25.5      | 25.6      | 29.7      |
|                                                | lbf-ft                | 14.1      | 18.8      | 18.9      | 21.9      |
| <b>Media temperature <sup>4)</sup></b>         |                       |           |           |           |           |
|                                                | °C                    | 2-50      | 2-50      | 2-50      | 2-50      |
|                                                | °F                    | 36-122    | 36-122    | 36-122    | 36-122    |
| <b>Ambient temperature</b>                     |                       |           |           |           |           |
|                                                | °C                    | 0-50      | 0-50      | 0-50      | 0-50      |
|                                                | °F                    | 32-122    | 32-122    | 32-122    | 32-122    |
| <b>Weight</b>                                  |                       |           |           |           |           |
|                                                | kg                    | 15        | 15        | 15        | 15        |
|                                                | lb                    | 33        | 33        | 33        | 33        |

<sup>1)</sup> For lower and higher pressure, please contact Danfoss High Pressure Pumps

<sup>2)</sup> If inlet pressure exceeds inlet operating pressure, Danfoss recommends inspection of the pump and shaft seal

<sup>3)</sup> For higher speed, please contact Danfoss High Pressure Pumps

<sup>4)</sup> Dependent on the NaCl concentration

**4.2 APP S 5.1-9.0**

| Pumps size                                     |                       | APP S 5.1 | APP S 6.5 | APP S 7.2 | APP S 8.2 | APP S 9.0 |
|------------------------------------------------|-----------------------|-----------|-----------|-----------|-----------|-----------|
| Code number                                    |                       | 180B7066  | 180B7067  | 180B7068  | 180B7069  | 180B7070  |
| Geometric displacement                         | cm <sup>3</sup> /rev. | 50        | 63        | 70        | 80        | 90        |
|                                                | in <sup>3</sup> /rev. | 3.05      | 3.84      | 4.27      | 4.88      | 5.49      |
| <b>Pressure</b>                                |                       |           |           |           |           |           |
| Outlet min. pressure, continuous <sup>1)</sup> | barg                  | 30        | 30        | 30        | 30        | 30        |
|                                                | psig                  | 435       | 435       | 435       | 435       | 435       |
| Outlet max. pressure, continuous <sup>1)</sup> | barg                  | 80        | 80        | 80        | 80        | 80        |
|                                                | psig                  | 1160      | 1160      | 1160      | 1160      | 1160      |
| Inlet operating pressure <sup>2)</sup>         | barg                  | 2.0-10    | 2.0-10    | 2.0-10    | 2.0-10    | 2.0-10    |
|                                                | psig                  | 29-145    | 29-145    | 29-145    | 29-145    | 29-145    |
| <b>Speed</b>                                   |                       |           |           |           |           |           |
| Min. speed, continuous                         | rpm                   | 700       | 700       | 700       | 700       | 700       |
| Max. speed, continuous                         | rpm                   | 1800      | 1800      | 1800      | 1800      | 1800      |
| <b>Typical Flow</b>                            |                       |           |           |           |           |           |
| 1000 rpm at max. pressure                      | m <sup>3</sup> /h     | 2.7       | 3.4       | 3.8       | 4.5       | 5.1       |
| 1800 rpm at max. pressure                      | m <sup>3</sup> /h     | 5.0       | 6.4       | 7.2       | 8.3       | 9.3       |
| 1200 rpm at max. pressure                      | gpm                   | 14.3      | 18.0      | 20.3      | 23.9      | 27.0      |
| 1800 rpm at max. pressure                      | gpm                   | 22.0      | 28.2      | 31.7      | 36.5      | 41.0      |
| <b>Typical motor size</b>                      |                       |           |           |           |           |           |
| 1500 rpm at max. pressure                      | kW                    | 15.0      | 15.0      | 18.5      | 18.5      | 22.0      |
| 1200 rpm at max. pressure                      | hp                    | 15.0      | 20.0      | 20.0      | 20.0      | 25.0      |
| <b>Torque at max outlet pressure</b>           |                       |           |           |           |           |           |
|                                                | Nm                    | 72.6      | 91.6      | 101.7     | 115.1     | 131.8     |
|                                                | lbf-ft                | 53.5      | 67.6      | 75.0      | 84.9      | 97.2      |
| <b>Media temperature <sup>3)</sup></b>         |                       |           |           |           |           |           |
|                                                | °C                    | 2-50      | 2-50      | 2-50      | 2-50      | 2-50      |
|                                                | °F                    | 36-122    | 36-122    | 36-122    | 36-122    | 36-122    |
| <b>Ambient temperature</b>                     |                       |           |           |           |           |           |
|                                                | °C                    | 0-50      | 0-50      | 0-50      | 0-50      | 0-50      |
|                                                | °F                    | 32-122    | 32-122    | 32-122    | 32-122    | 32-122    |
| <b>Weight</b>                                  |                       |           |           |           |           |           |
|                                                | kg                    | 40        | 40        | 40        | 40        | 40        |
|                                                | lb                    | 88        | 88        | 88        | 88        | 88        |

<sup>1)</sup> For lower and higher pressure, please contact Danfoss High Pressure Pumps

<sup>2)</sup> If inlet pressure exceeds inlet operating pressure, Danfoss recommends inspection of the pump and shaft seal

<sup>3)</sup> Dependent on the NaCl concentration

**4.3 APP S 21-38**

| Pumps size                                     |                       | APP S 21   | APP S 24   | APP S 26   | APP S 30   | APP S 33   | APP S 38   |
|------------------------------------------------|-----------------------|------------|------------|------------|------------|------------|------------|
| Code number                                    |                       | On request | On request | On request | On request | On request | On request |
| Geometric displacement                         | cm <sup>3</sup> /rev. | 256        | 282        | 308        | 362        | 389        | 444        |
|                                                | in <sup>3</sup> /rev. | 15.6       | 17.2       | 18.8       | 22.1       | 23.7       | 27.1       |
| <b>Pressure</b>                                |                       |            |            |            |            |            |            |
| Outlet min. pressure, continuous <sup>1)</sup> | barg                  | 10         | 10         | 10         | 10         | 10         | 10         |
|                                                | psig                  | 145        | 145        | 145        | 145        | 145        | 145        |
| Outlet max. pressure, continuous <sup>1)</sup> | barg                  | 80         | 80         | 80         | 80         | 80         | 80         |
|                                                | psig                  | 1160       | 1160       | 1160       | 1160       | 1160       | 1160       |
| Inlet operating pressure <sup>2)</sup>         | barg                  | 2.0-10     | 2.0-10     | 2.0-10     | 2.0-10     | 2.0-10     | 2.0-10     |
|                                                | psig                  | 29-145     | 29-145     | 29-145     | 29-145     | 29-145     | 29-145     |
| <b>Speed</b>                                   |                       |            |            |            |            |            |            |
| Min. speed, continuous                         | rpm                   | 700        | 700        | 700        | 700        | 700        | 700        |
| Max. speed, continuous                         | rpm                   | 1500       | 1500       | 1500       | 1500       | 1500       | 1500       |
| <b>Typical Flow</b>                            |                       |            |            |            |            |            |            |
| 700 rpm at max. pressure                       | m <sup>3</sup> /h     | 10         | 11         | 12         | 14         | 15.2       | 17.5       |
| 1500 rpm at max. pressure                      | m <sup>3</sup> /h     | 21.9       | 24.2       | 26.7       | 31.3       | 33.3       | 38.4       |
| 700 rpm at max. pressure                       | gpm                   | 44         | 48.4       | 52.8       | 61.6       | 67         | 77         |
| 1500 rpm at max. pressure                      | gpm                   | 96.4       | 106.5      | 117.6      | 138        | 146.6      | 169        |
| <b>Typical motor size</b>                      |                       |            |            |            |            |            |            |
| 1000 rpm at max. pressure                      | kW                    | 45         | 45         | 55         | 55         | 75         | 75         |
| 1000 rpm at max. pressure                      | hp                    | 60         | 60         | 75         | 75         | 100        | 100        |
| <b>Torque at max. outlet pressure</b>          |                       |            |            |            |            |            |            |
| Torque at max. outlet pressure                 | Nm                    | 371        | 413        | 451        | 530        | 556        | 639        |
|                                                | lbf-ft                | 273.6      | 304.6      | 332.6      | 391        | 410        | 471.3      |
| Media temperature <sup>3)</sup>                | °C                    | 2-50       | 2-50       | 2-50       | 2-50       | 2-50       | 2-50       |
|                                                | °F                    | 36-122     | 36-122     | 36-122     | 36-122     | 36-122     | 36-122     |
| Ambient temperature                            | °C                    | 0-50       | 0-50       | 0-50       | 0-50       | 0-50       | 0-50       |
|                                                | °F                    | 32-122     | 32-122     | 32-122     | 32-122     | 32-122     | 32-122     |
| Weight                                         | kg                    | 118        | 118        | 118        | 118        | 118        | 118        |
|                                                | lb                    | 260        | 260        | 260        | 260        | 260        | 260        |

<sup>1)</sup> For lower and higher pressure, please contact Danfoss High Pressure Pumps

<sup>2)</sup> If inlet pressure exceeds inlet operating pressure, Danfoss recommends inspection of the pump and shaft seal

<sup>3)</sup> Dependent on the NaCl concentration

5. Flow

If the required flow and rotation speed (rpm) of the pump are known, the below diagram can be used to select the pump that fits the application best.

5.1 APP S 2.0-3.5 flow curves at max. pressure

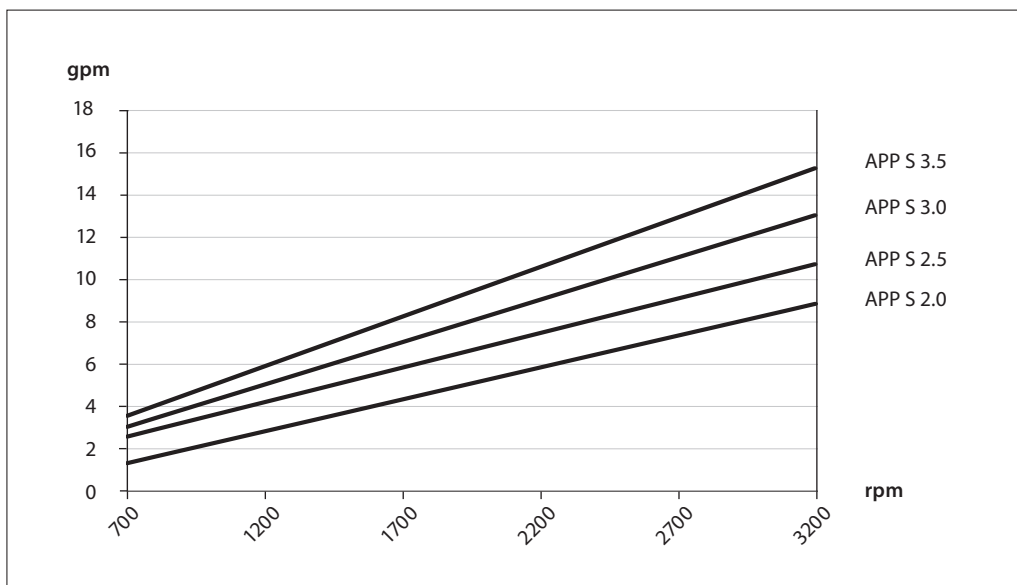
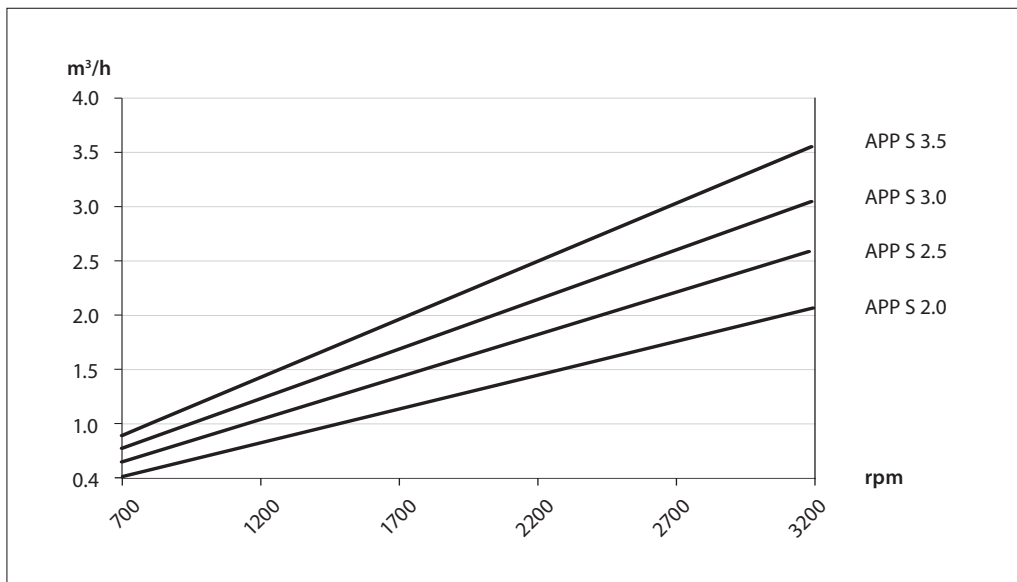

5.2 APP S 5.1-9.0 flow curves at max. pressure

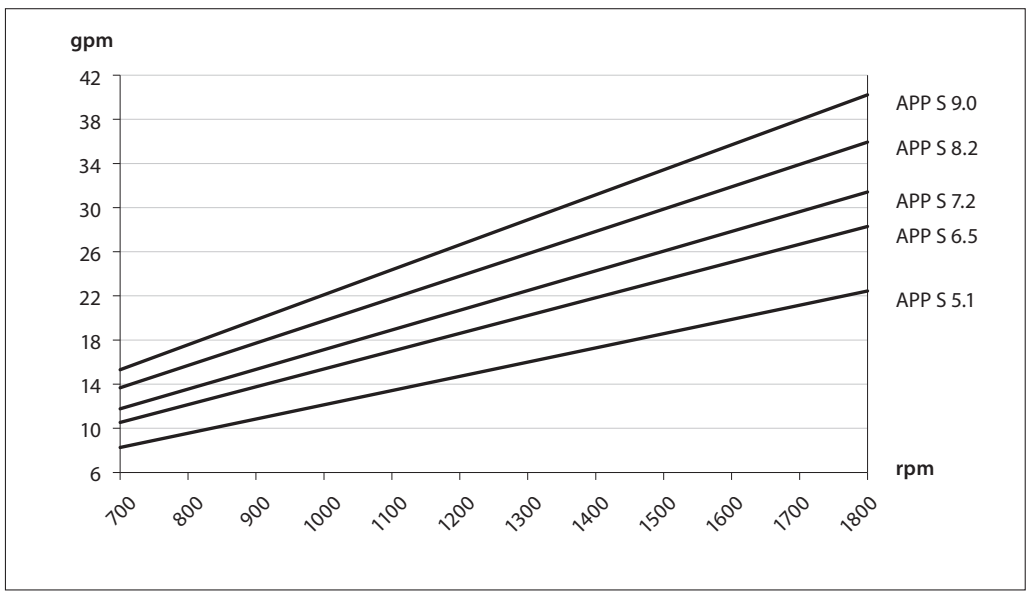
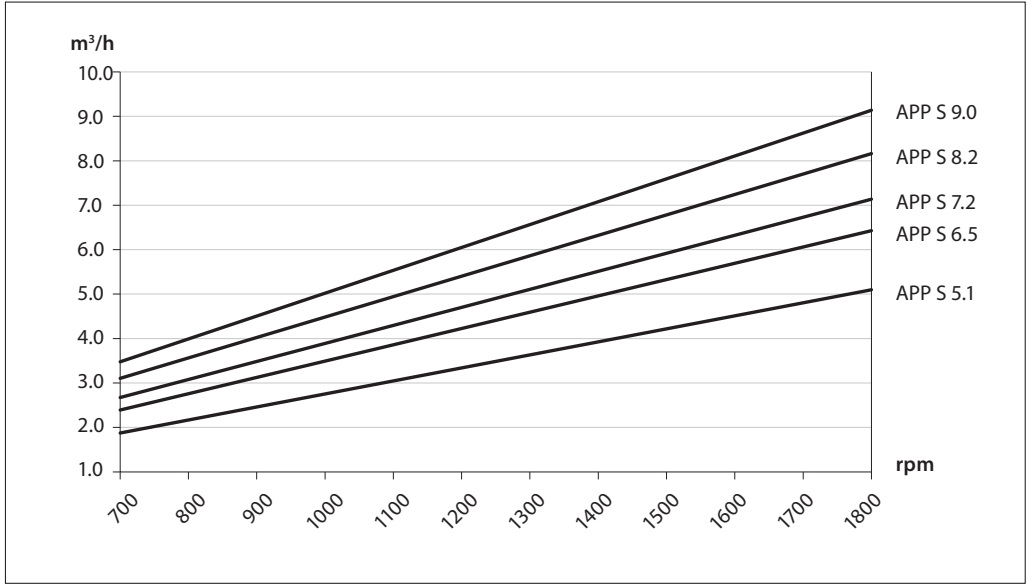

5.3 APP S 21-38 flow curves at max. pressure

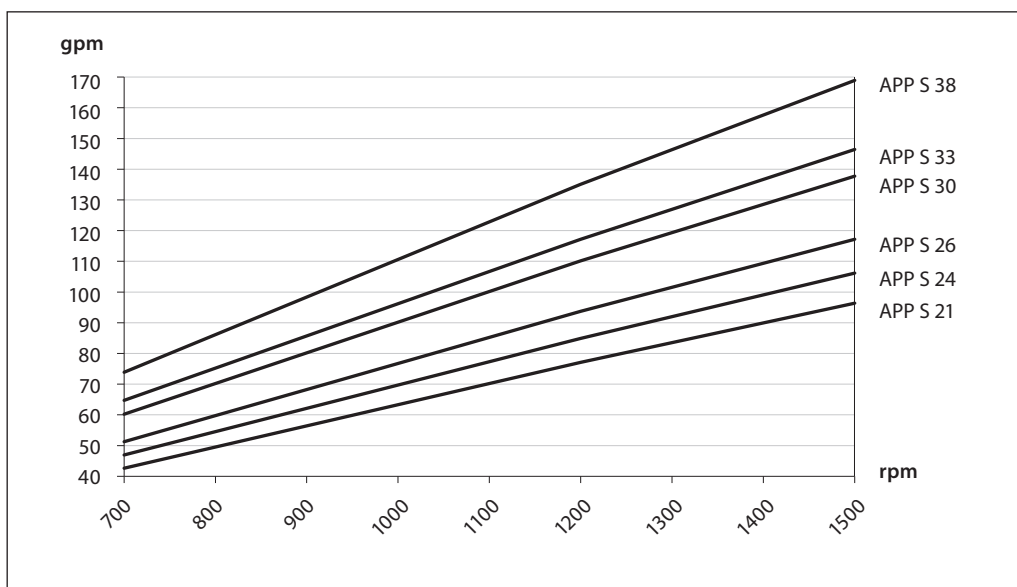
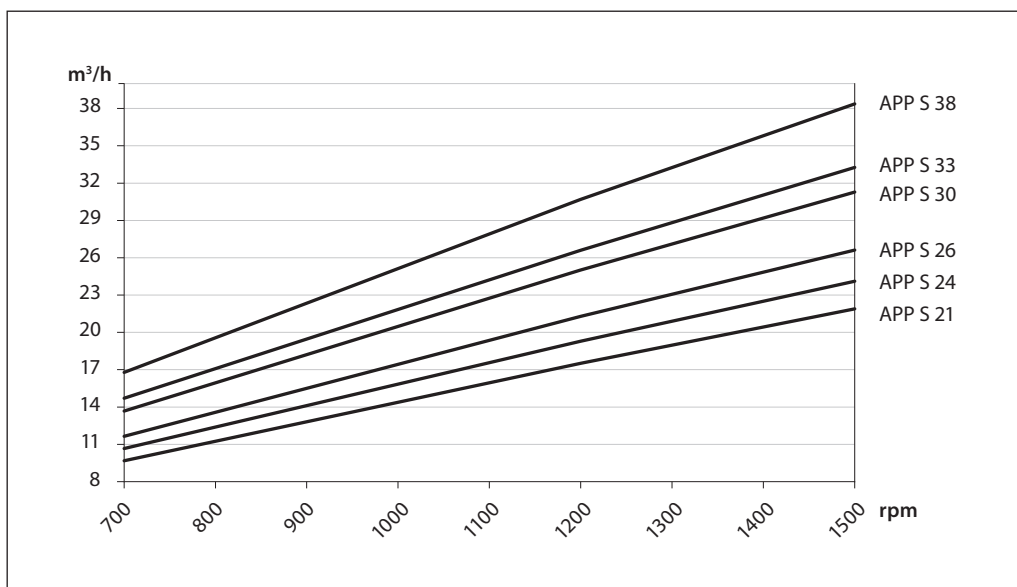

The curves above also show that the flow can be changed by changing the rotation speed of the pump. The flow/rpm ratio is constant, and the "required " flow can be obtained by changing the rotation speed to a corresponding value. Thus, the required rpm can be determined as:

$$\text{Required rpm} = \frac{\text{Required flow} \times \text{Typical rpm}}{\text{Typical flow}}$$

**5.4 Flushing valve characteristics**

The diagrams show the flow characteristics of the integrated flushing valve that allows the water to flow from inlet to outlet when the pump is not running.

**5.4.1 APP S 2.0-3.5 integrated flushing valve curve**

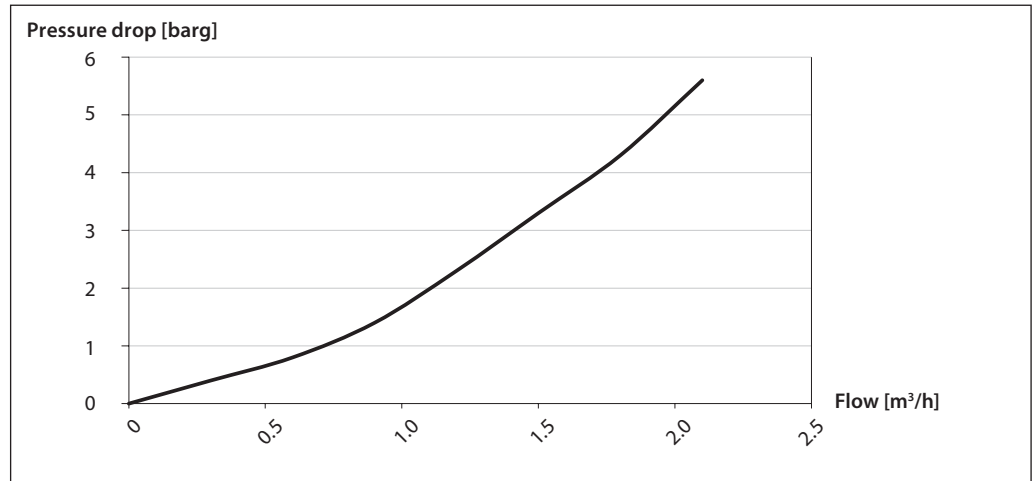

**5.4.2 APP S 5.1-9.0 integrated flushing valve curve**

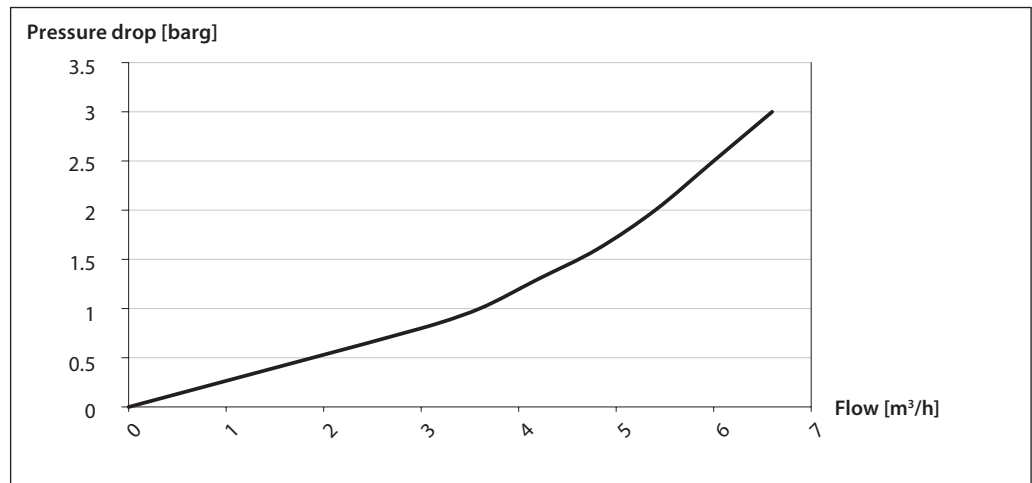

**5.4. APP S 21-38 integrated flushing valve curve**

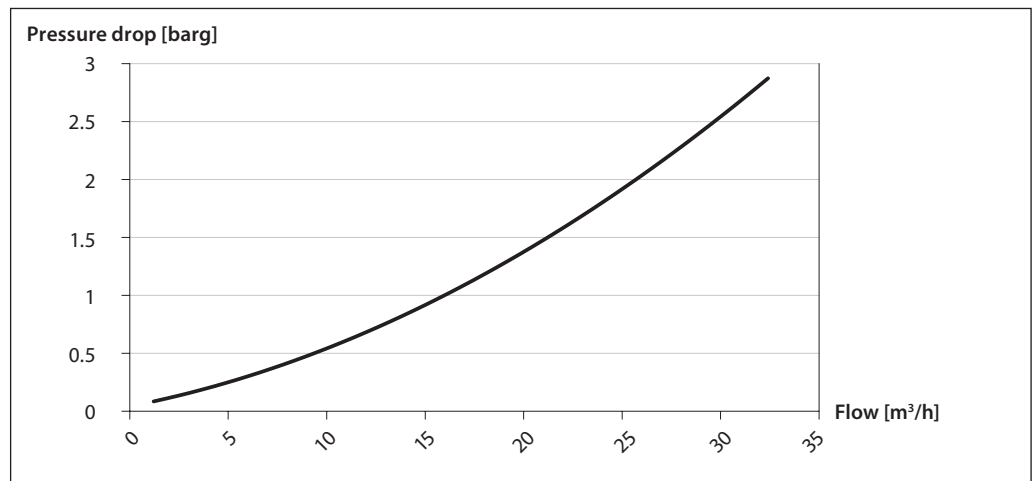

6. Corrosion

The chart below illustrates the corrosive resistance of different types of stainless steel related to NaCl concentration and temperature.

If the water pump is operated at high salinity, always flush the water pump with fresh water at operation stop, in order to minimize the risk of crevice corrosion.

All wetted parts of the APP S pumps are made of Super Duplex.

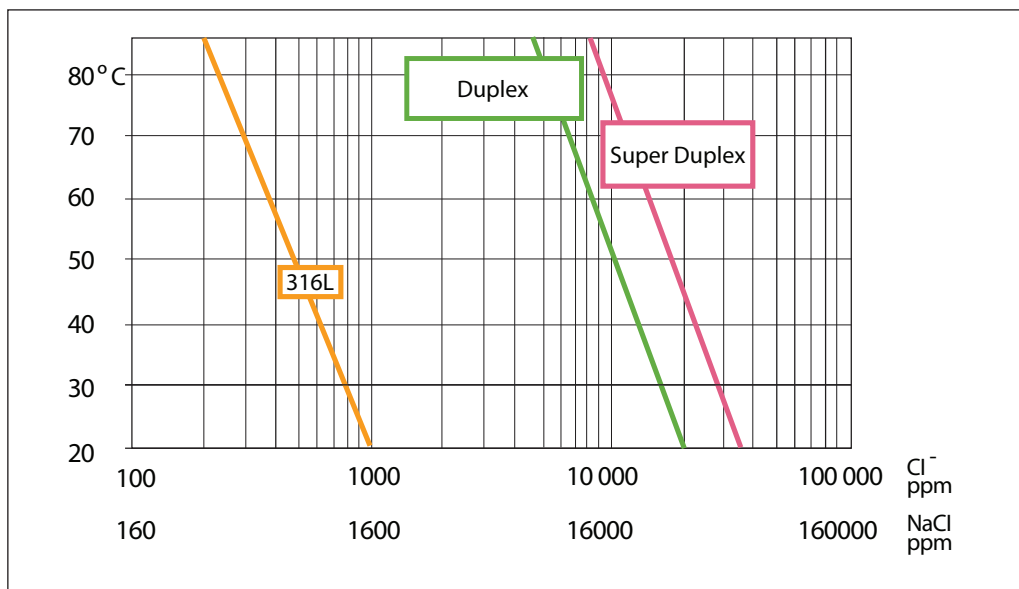

7. Motor requirements

The power requirements can be determined using one of the following guiding equations:

$$\text{Required power} = \frac{\text{l/min} \times \text{barg}}{\text{Calc. factor}} \text{ [kW]} \text{ or } \frac{16.7 \times \text{m}^3/\text{h} \times \text{barg}}{\text{Calc. factor}} \text{ [kW]} \text{ or } \frac{0.26 \times \text{gpm} \times \text{psig}}{\text{Calc. factor}} \times 1.34 \text{ [hp]}$$

|                                |                                |                                   |
|--------------------------------|--------------------------------|-----------------------------------|
| 1 hp = 0.75 kW                 | 1 kW = 1.34 hp                 | APP S 2.0-3.5 - Calc. factor: 485 |
| 1 gpm = 3.79 l/min             | 1 l/min = 0.26 gpm             | APP S 5.1-9.0 - Calc. factor: 485 |
| 1 m <sup>3</sup> /h = 4.40 gpm | 1 gpm = 0.23 m <sup>3</sup> /h | APP S 21-38 - Calc. factor: 504   |

Both power and torque requirement must be verified in order to determine the correct motor size when the motor does not operate at nominal speed.

8. Installation

The figure below illustrates how to mount and connect all pump sizes to an electric motor or combustion engine. If alternative mounting is required, please contact Danfoss High Pressure Pumps for further information.

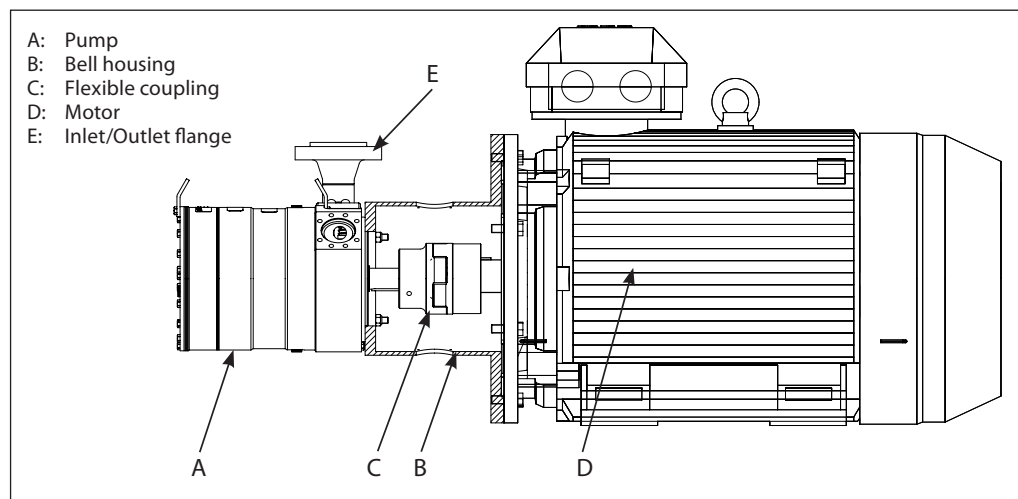

8.1 Filtration

**Proper filtration is crucial for the performance, maintenance and warranty of your pump.**

Protect your pump, the application in which it is installed by always ensuring that all filtration specifications are met, and by always changing filter cartridges according to schedule.

Since water has very low viscosity, Danfoss APP S pumps have been designed with very narrow clearances in order to control internal leakage rates and improve pump performance. **To minimize wear on the pump, it is therefore essential to filter inlet water properly:**

**The main filter must have a filtration efficiency of 99.98% at 10 µm. We strongly recommend that you always use precision depth filter cartridges rated 10µm abs.  $\beta_{10} \geq 5,000$ .**

Please note that **we do not recommend bag filters or string-wound filter cartridges**, which typically have only 50% filtration efficiency. This means that out of 100,000 particles that enter such filters, 50,000 particles pass right through them; compare this to precision depth filters that are 99.98% efficient, and only allow 20 of the same 100,000 particles to pass through.

For more information on the importance of proper filtration, including explanation of filtration principles, definitions, and guidance on how to select the right filter for your pump, please consult our **Filtration** information and specifications (Danfoss document number 521B1009).

8.2 Noise

Since the pump unit is mounted on a frame, the overall noise level can only be determined for a complete system. To minimize vibrations and noise throughout the system, it is therefore recommended to mount the pump unit correctly on a frame with dampeners and to use flexible hoses rather than metal pipes where possible.

**The noise level is influenced by:**

- **Pump speed:**  
High rpm makes more fluid/structure-borne pulsations/vibrations than low rpm due to higher frequency.
- **Discharge pressure:**  
High pressure makes more noise than low pressure.
- **Pump mounting:**  
Rigid mounting makes more noise than flexible mounting due to structure-borne vibrations.
- **Connections to pump:**  
Pipes connected directly to the pump make more noise than flexible hoses due to structure-borne vibrations.
- **Variable frequency drives (VFD):**  
Motors regulated by VFDs can increase noise level if the VFD does not have the right settings.

The curves on the following page indicate the sound pressure level in dB(A) measured in a reverberation room at a distance of 1 metre from the motor/pump unit surface. The measurements is according to EN ISO 3744: 2010 and the dB(A)  $[L_{PA'} 1m]$  values is calculated.

8.2.1 APP S 2.0-3.5 pump mounted on motor 5.5 kW 4-pole / 11 kW 2-pole

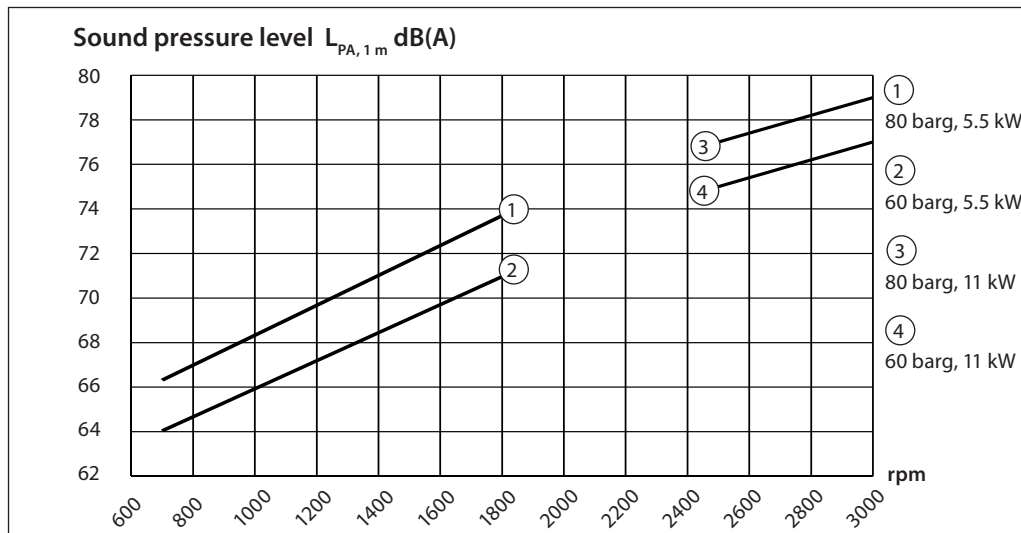

8.2.2 APP S 5.1-9.0 pump mounted on motor 22 kW 4-pole

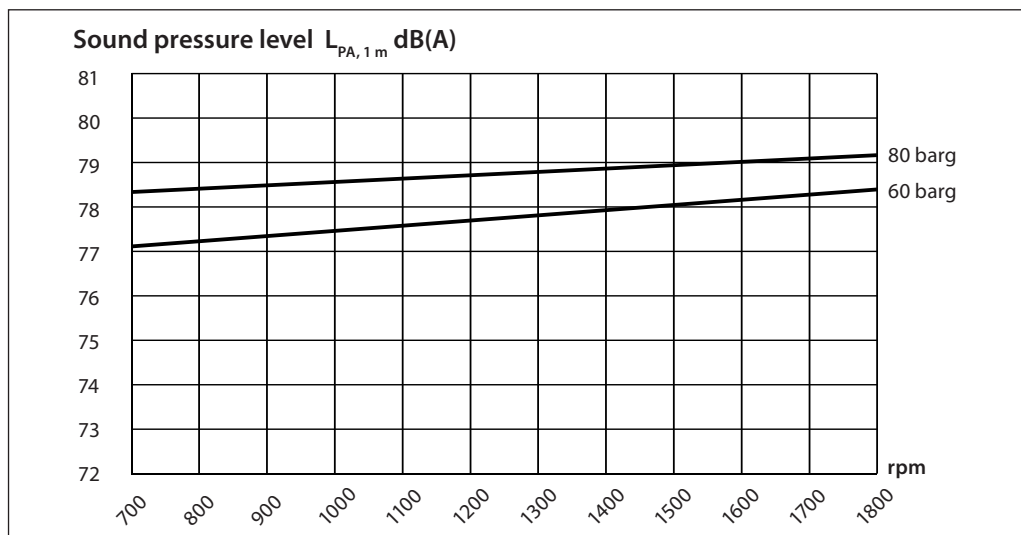

8.2.3 APP S 21-38 pump mounted on motor 75 kW 4-pole

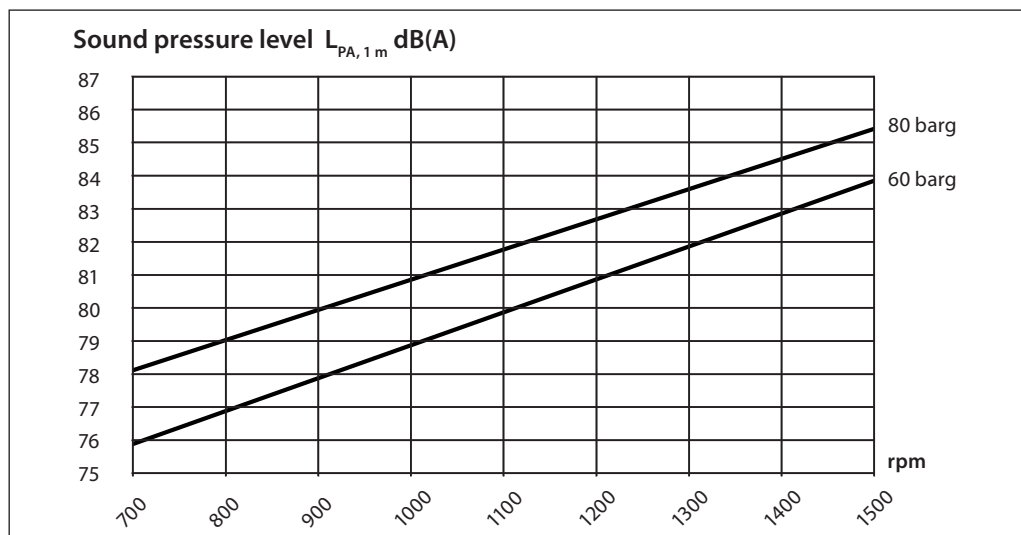

**8.3 Open system design**

- A Inlet line:**  
Minimize pressure loss by allowing for maximum flow, minimum pipe length, as few bends/connections as possible, and fittings with small pressure losses.
- B Inlet filter:**  
Install the inlet filter (1) in front of the APP S pump (4). Please consult the Danfoss filter data sheet for guidance on how to select the right filter.
- C Monitoring pressure switch:**  
Install the monitoring pressure switch (3) between the filter and the pump inlet. Set the minimum inlet pressure according to pump specifications. The monitoring pressure switch stops the pump if inlet pressure is lower than the set minimum pressure.
- D Monitoring temperature switch when the pump operates in a hazardous area:**  
Install the monitoring temperature switch between the filter and the pump, on either side of the monitoring pressure switch. Set the temperature according to pump specifications. The monitoring temperature switch stops the pump if inlet temperature is higher than the set value.

- E Connections:**  
Ensure flange loads (5) do not exceed max. allowable loads on connections.
- F Inlet pressure:**  
In order to eliminate the risk of cavitation and other pump damage, inlet pressure must be maintained within pump specifications.
- G LP relief valve (2):**  
Can be installed in order to avoid system or pump damage in case the pump stops momentarily or spinning backwards.
- H HP relief valve:**  
As the Danfoss APP S pump begins to create pressure and flow immediately after start-up and regardless of any counter pressure, a pressure relief valve (6) should be installed to prevent system damage.

**Note: If a non-return valve is mounted in the inlet line, a low-pressure relief valve is also required between the non-return valve and the pump to protect against high-pressure peaks.**

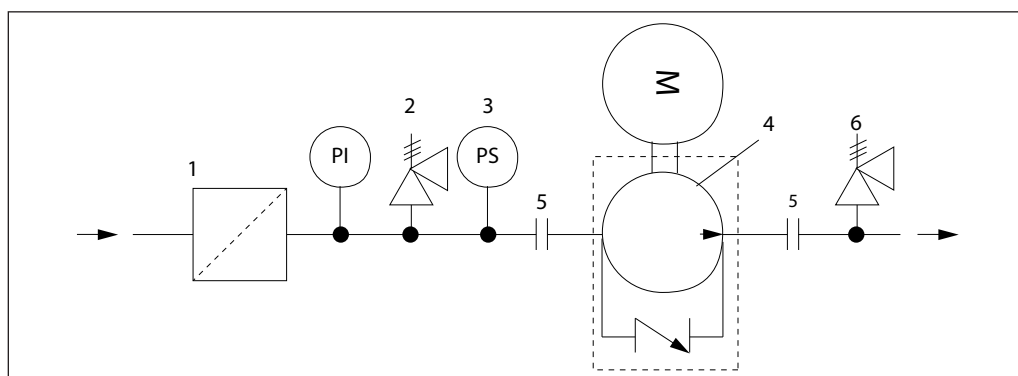

**8.4 RO system with APP S pump**

The numbers in brackets refer to the drawing on next page.

- A** Dimension the inlet line to obtain minimum pressure loss (large flow, minimum pipe length, minimum number of bends/connections, and fittings with small pressure losses).
- B** Place an inlet filter (1) in front of the APP S pump (2). Please consult section 10, "Filtration" for guidance on how to select the right filter. Thoroughly clean pipes and flush system prior to start-up.
- C** Place a monitoring pressure switch (3) set at min. inlet pressure between filter and pump inlet.  
The monitoring switch must stop the pump at pressures lower than minimum pressure.
- D** Ensure flange loads (4) do not exceed max. allowable loads on process connections.
- E** In order to eliminate the risk of damage and cavitation, a positive pressure at the inlet (5) is always to be maintained at min. inlet pressure and max. inlet pressure. Recommend to install safety valve or a pressure

relief valve (9) in order to avoid high pressure peaks in case the pump stops momentarily or is spinning backwards.

- F** For easy system bleeding and flushing, a bypass non-return valve (6) is integrated in the APP S pump.
- G** A non-return valve (7) in outlet can be installed in order to avoid backspin of the pump. The volume of water in the membrane vessel works as an accumulator and will send flow backwards in case the pump stops momentarily.
- H** A safety valve or a pressure relief valve (8) can be installed in order to avoid system damage as the Danfoss APP S pump creates pressure and flow immediately after start-up, regardless of any counter pressure.

**Note: If a non return valve is mounted in the inlet line, a low pressure relief valve is also required between non return valve and pump as protection against high pressure peaks.**

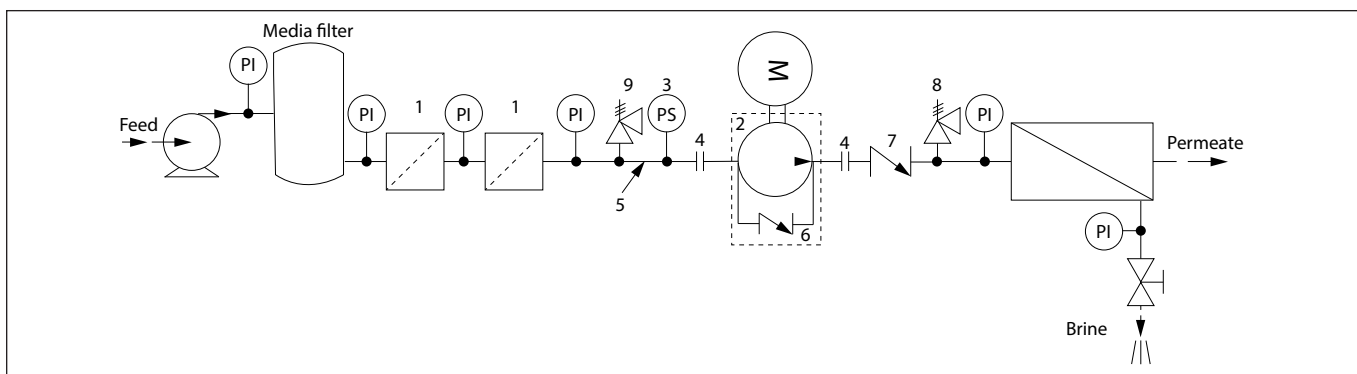

9. Dimensions and connections

9.1 APP S 2.0-3.5

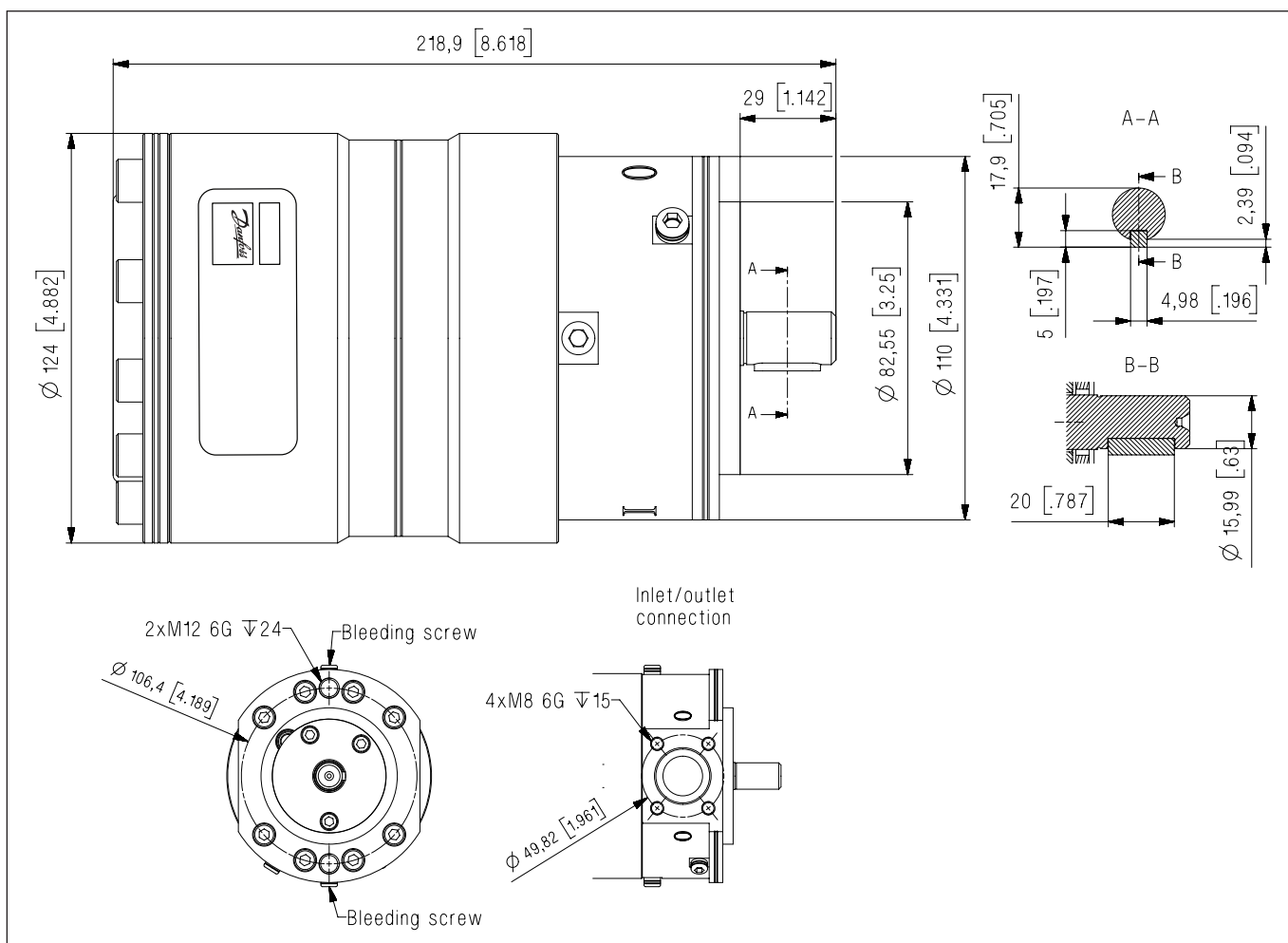

| Description                     | APP S 2.0-3.5                     |
|---------------------------------|-----------------------------------|
| Parallel key, DIN 6885, mm (in) | 5 × 5 × 5<br>(0.20 × 0.20 × 0.78) |
| Bleeding                        | M6; Hexagon, Allen key 5 mm       |
| Inlet port                      | 4 bolt flange                     |
| Outlet port                     | 4 bolt flange                     |
| Pump mounting flange            | ISO 3019-1 82-2                   |

| Accessories        | Type       |
|--------------------|------------|
| 3/4" inlet flange  | ASME B16.5 |
| 3/4" outlet flange | ASME B16.5 |

For other requirements on flange connections, please contact Danfoss High Pressure Pumps.

9.2 APP S 5.1-9.0

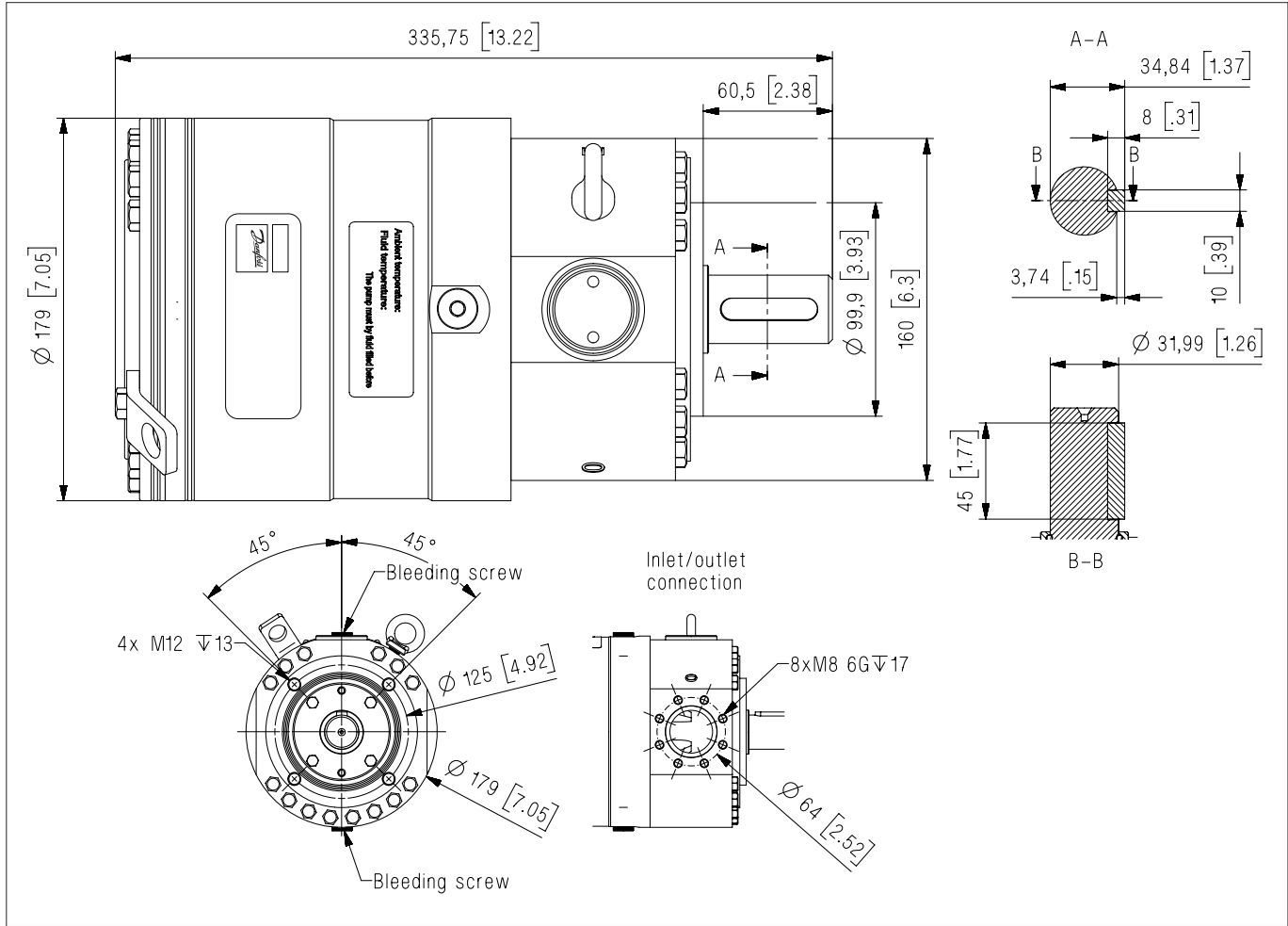

| Description                     | APP S 5.1-9.0                     |
|---------------------------------|-----------------------------------|
| Parallel key, DIN 6885, mm (in) | 10 × 8 × 45<br>0.39 × 0.31 × 1.77 |
| Bleeding                        | G 1/4"; Hexagon, Allen key 6 mm   |
| Inlet port                      | 8 bolt flange                     |
| Outlet port                     | 8 bolt flange                     |
| Pump mounting flange            | ISO 3019-2 100 B4                 |

| Accessories          | Type       |
|----------------------|------------|
| 1 1/2" inlet flange  | ASME B16.5 |
| 1 1/2" outlet flange | ASME B16.5 |

For other requirements on flange connections, please contact Danfoss High Pressure Pumps.

9.3 APP S 21-38

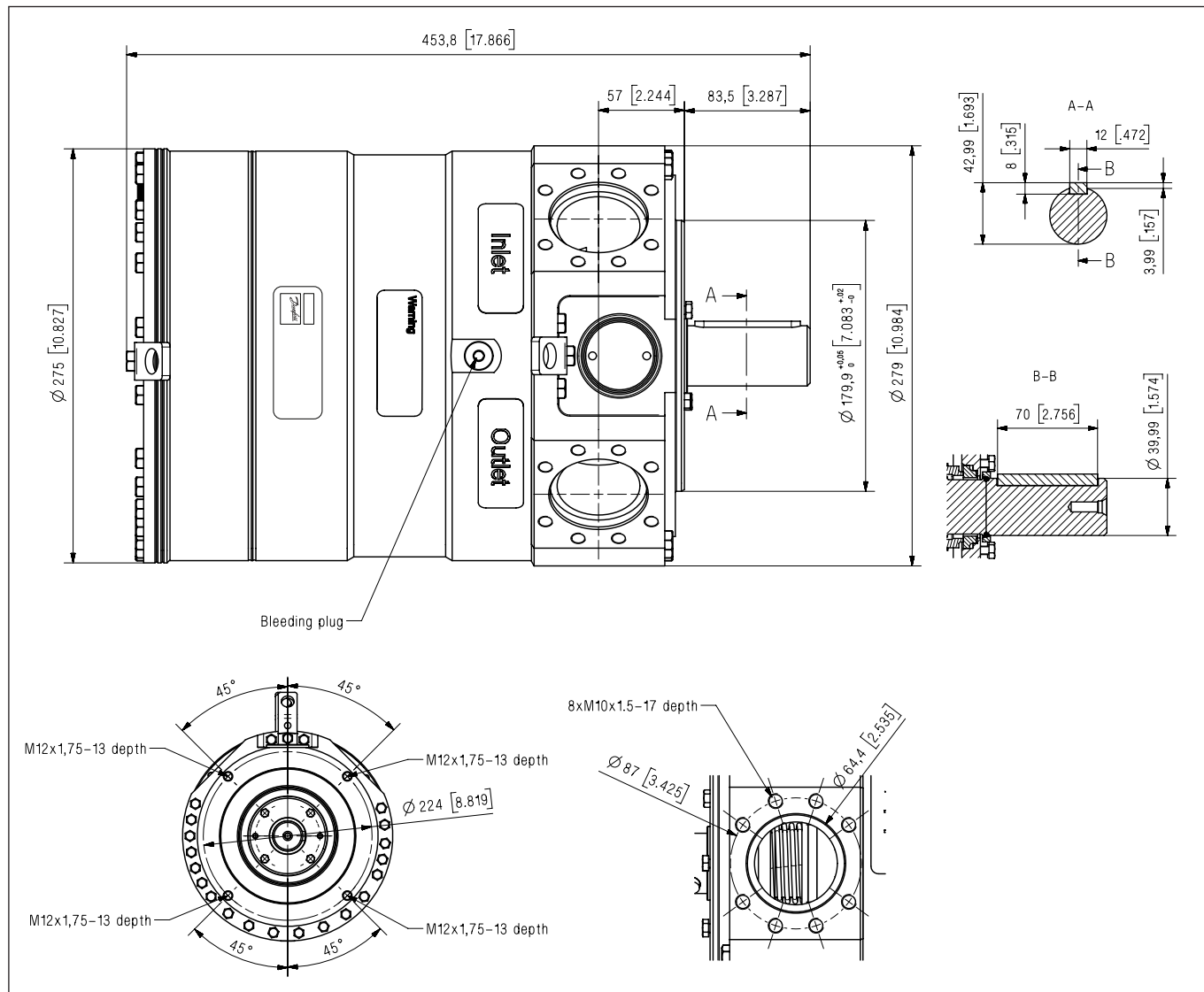

| Description                     | APP S 21-38                      |
|---------------------------------|----------------------------------|
| Parallel key, DIN 6885, mm (in) | 12 × 8 × 70 (0.47 × 0.31 × 2.76) |
| Bleeding                        | G ¼"; Hexagon, Allen key 8 mm    |
| Inlet port                      | 8 bolt flange                    |
| Outlet port                     | 8 bolt flange                    |
| Pump mounting flange            | ISO 3019-2 180 B4 TW             |

| Accessories      | Type       |
|------------------|------------|
| 2" inlet flange  | ASME B16.5 |
| 2" outlet flange | ASME B16.5 |

For other requirements on flange connections, please contact Danfoss High Pressure Pumps.

**10. Service****10.1 Warranty**

Danfoss APP S pumps are designed for long operation, low maintenance and reduced lifecycle costs.

Provided that the pump has been running according to the Danfoss specifications, Danfoss guarantees 8,000 hours service-free operation, however, max. 18 months from date of production.

If Danfoss recommendations concerning system-design are not followed, *it will strongly influence the life of the APP S pumps.*

Other factors that affect pump performance and lifetime include:

- Running the pump at speeds outside specifications.
- Supplying the pump with water at temperatures higher than recommended.
- Running the pump at inlet pressures outside specifications.
- Running the pump at outlet pressures outside the specifications.

**10.2 Maintenance**

After 8,000 hours of operation **it is strongly recommended to inspect the pump and change any worn parts, e.g. pistons and shaft seal.** This is done in order to prevent a potential breakdown of the pump.

If the parts are not replaced, more frequent inspection is recommended according to our guidelines.

**Pump shutdown**

The APP S pumps are made of Super Duplex materials with excellent corrosion properties. **It is, however, always recommended to flush the pump with freshwater when the system is shut down.**

**Repair**

In case of irregular function of the APP S pump, please contact Danfoss High Pressure Pumps.

**Danfoss A/S**  
High Pressure Pumps  
DK-6430 Nordborg  
Denmark

---

Danfoss can accept no responsibility for possible errors in catalogues, brochures and other printed material. Danfoss reserves the right to alter its products without notice. This also applies to products already on order provided that such alterations can be made without subsequential changes being necessary in specifications already agreed. All trademarks in this material are property of the respective companies. Danfoss and the Danfoss logotype are trademarks of Danfoss A/S. All rights reserved.

---