

Instructions for installation and use

Indirect, fully insulated district heating substations Akva Lux II VXi, VXi Solo

Indirect district heating substation for heating and domestic hot water.

VXi

Fully insulated
for very low
heat losses.



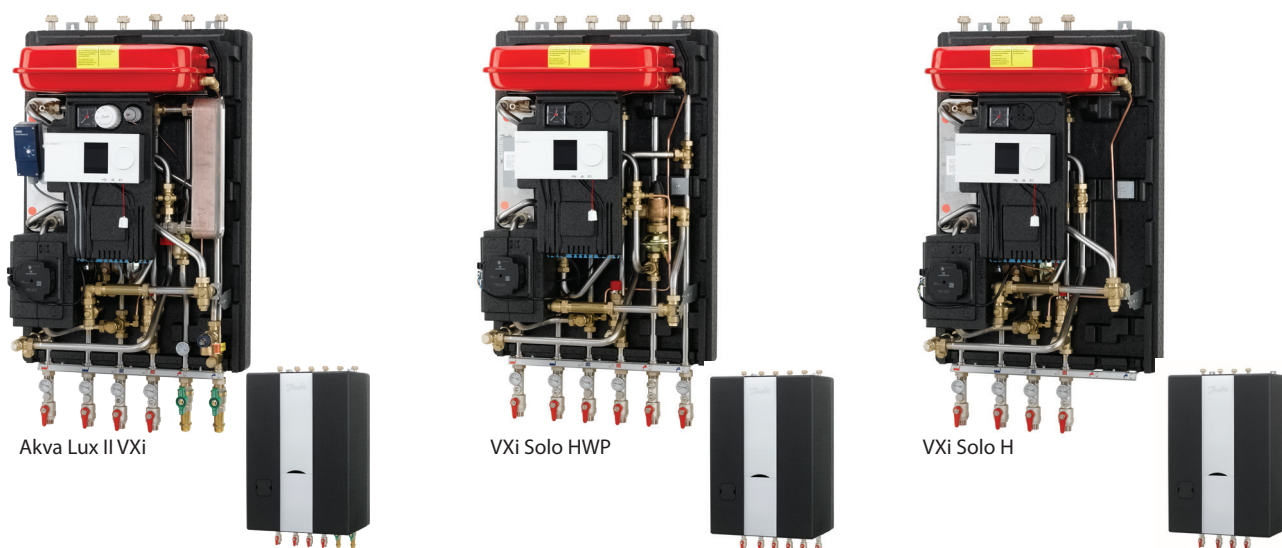

1.0 Content

2.0	Installation instructions, safety and handling.....	3
3.0	Getting started - Quick guide for easy start-up.....	4
4.0	Main components / Connections	6
5.0	Diagrams, Dimensional sketches, Examples.....	8
6.0	General, Mounting of heat meter and safety valves.....	11
7.0	Filling the system with water	12
8.0	Variable connection possibilities	13
9.0	Recirculation (only Akva Lux II VXi)	14
10.0	Electrical connections.....	15
11.0	Adjustment and commissioning	16
12.0	Heating circuit, Danfoss ECL 210/310 automatics	17
13.0	Control of heating circuit.....	18
14.0	Heating circuit, pump and summer operation	20
15.0	Domestic hot water	22
16.0	Maintenance.....	24
17.0	Troubleshooting	26
18.0	EU Declaration of conformity.....	30
19.0	Commissioning Certificate.....	31

2. INSTALLATION INSTRUCTIONS, SAFETY AND HANDLING

Instructions

Please read these instructions carefully before installing and commissioning this substation. The manufacturer accepts no liability for loss or damage resulting from failure to comply with these instructions for use.

Read and follow these instructions carefully to prevent the risk of physical injury and/or damage to property. Exceeding the recommended operating parameters considerably increases the risk of personal injury and/or damage to property. Installation, commissioning and maintenance must be carried out by qualified and authorized personnel in compliance with the local safety regulations.

Once the station has been installed and is operating, there is *normally* no need to alter the settings or other functions. The district heating substation is very reliable and easy to operate.

Energy source

The substation is primarily designed for connection to district heating. Alternative energy sources can be used if the operating conditions are equivalent to district heating at all times.

Application

The substation is designed only to operate with water and other heating media may not be used.

The substation is to be connected to the household piping in a frost-free room, where the temperature does not exceed 50 °C and the relative humidity is not higher than 80%. The substation must not be covered, bricked in or otherwise cut off from access.

Choice of materials

Only use materials, that comply with local regulations.

Corrosion protection

The risk of equipment corrosion increases considerably if recommended permissible chloride compounds are exceeded.

All pipes are made of min. AISI 304 (heating) and min. AISI 316 (domestic water) stainless steel as well as brass. Components for domestic water, however, primarily in dezincification-resistant brass. Heat exchangers are made of stainless steel and are copper-soldered or steel-soldered.

Surfaces in contact with water can be subject to two problems, limescale formation and corrosion.

The nature of the water will be of great importance in this context, where the pH value, chlorides, gases, etc., have a decisive effect on how much lime is deposited and how aggressive the water is.

The temperature also has a great influence in this context. For example the corrosion rate increases by a factor of 2 to 3 for every 10° C temperature rise. With knowledge of the chemical water composition and operating conditions of a heating system, the risk of scaling and corrosion can be assessed. Based on that, recommendations can be made to avoid scaling and/or corrosion problems in the components.

See item 19, page 41 for more detailed Guidelines for Water Quality in Danfoss brazed heat exchangers and recommended Chloride concentration to avoid Stress Corrosion Cracking.

Safety valve(s)

Installation of safety valve(s) must always be in compliance with local regulations.

Noise level.

≤ 55 dB.

PTC2+P controller for domestic hot water

The controller is preset from factory and sealed with a red sticker. This sealing must not be broken.

The warranty becomes void if the sealing is broken.



Storage

Before installation, the units must be stored in a dry, heated (if frost-free) room.

(Relative humidity max. 80% and storage temperature 5-70 °C).

The units must not be stacked higher than the limit at the factory (max. 8 layers).

Units supplied in cardboard packaging must be lifted using the handles incorporated in the packaging. Units must be placed on pallets for transport/moving across large distances.

As far as possible, do not lift the substation by the pipes. Lifting by the pipes may cause leaks. REMEMBER to retighten.

Disposal

Dispose of the packaging in accordance with the local regulations for disposal of used packaging materials.

The substation is made of materials that cannot be disposed of together with household waste.

Close all energy sources and disconnect all connection pipes. Disconnect



Connection

It must be possible to cut off all energy sources to the unit - including electrical connections - at all times. The unit must be connected to an electrical equalizer connection.

Warning! Hot surfaces

Parts of the substation may be very hot and can cause burn injuries. Be very careful when you are in the immediate vicinity of the substation.

Warning of high pressure and high temperature

The maximum supply temperature in the district heating network can be up to 120°C and the operating pressure can be up to 16 bar. This may result in a risk of scalding from touching the substation and from outflow of the medium (water/steam). Exceeding the substation design data and operating parameters for pressure and temperature carries an appreciable risk of personal injury and/or damage to property.

Emergencies

In the event of fire, leaks or other hazards, immediately shut off all sources of energy to the substation, if possible and call for appropriate assistance.

If the domestic hot water is discoloured or malodorous, shut off all ball valves on the substation, notify all users and call for professional assistance immediately.

Warning of damage during transport

On reception of the substation, and before installing it, check for any evidence of damage during transport.

The substation must be handled and moved with the greatest care and attention.

IMPORTANT - Tightening of connections

Before adding water to the system, ALL pipe connections MUST be retightened, as vibrations during transport may have caused leaks. Once the substation has been filled and the system has been put into operation, ALL pipe connections MUST be tightened once more.

(Do not overtighten! - See page 8, Test and Connections)



Handling

We recommend that you wear suitable safety footwear while handling and installing the substation.

NOTE: Interventions/rework on our components results in loss of warranty.

2. INSTALLATION INSTRUCTIONS, SAFETY AND HANDLING

Potential equalization / grounding

Equipotential bonding is understood as all measures for eliminating electrical potential differences (contact voltages), which can occur between eg two pipelines. Equipotential bonding is an important measure for protection against electric shock.

Equipotential bonding reduces corrosion in the heat exchanger, instantaneous water heaters, district heating stations and plumbing installations. Equipotential bonding should be in accordance with the provisions 60364-4-41: 2007 and IEC 60364-5-54: 2011.

Binding point is marked with a grounding symbol on the bottom right corner of the mounting plate and there e page 31.



The station is easily mounted on the wall. It is recommended that at least two people are involve in the installation.

Note: Never lift the unit by its front insulation cover!



By removing the white front panel, easy access is provided to the display and components for regulatory and maintenance purposes.



Easy access for setting the ECL 210/310 controller.



Through the cut-out piece in the front insulation cover free access is provided to the pump.



The control panel is removed with a single click, and allows easy access to the components behind it.



The front insulation cover can easily be removed without tools.



The station can easily be connected to the household piping.



Please note: The VXi station is shown here with ECL 110 controller, - but it is supplied with ECL 210 or 310 controller.

3. GETTING STARTED - QUICK GUIDE FOR EASY START-UP

Mounting

Connect the substation to the household piping in accordance with the labelling at the bottom and/or in accordance with the instructions in this manual. Upon delivery the substation is prepared for connection in bottom of the substation, but can also be established in top.

If the household piping system features domestic hot water recirculation, the substation must be connected to the recirculation system. The circulation set for recirculation connection is not standard equipment. The set must be purchased as extra equipment.

We recommend establishing recirculation BEFORE mounting the substation on the wall.

For instructions about recirculation connection, see page 14.

GETTING STARTED is a quick guide and some details in connection with installation and commissioning may require additional information, which can be found elsewhere in this instruction manual.

GETTING STARTED AKVA LUX II VXI

The VXi substations offer variable connection possibilities, as connections of pipes can be established in the top or in the bottom of the substation.- Upon delivery the substation is prepared for connection in bottom of the substation. For change of connection from bottom to top, demount plugs on connection pipes in top of substation and ball valves on connection pipes in bottom of substation, and mount plugs in connection pipes in bottom of substation. See page 13 for further information.

For connection in TOP for DCW and DHW please note that this includes relocation of the built-in blind plates BEFORE mounting the substation on the wall. (Please see instruction on page 13 for further information).

If the household piping system features domestic hot water recirculation, the substation must be connected to the recirculation system, - according to instructions on page 14.

1. Mount the substation on a solid wall using two sturdy bolts (max. 8 mm), screws, expansion bolts or similar.

2. Tighten all pipe connections, as they may have loosened during transport and handling.

3. Mount the district heating meter (see page 11).

4. On systems that feature a safety valve, establish a drain connection in compliance with the applicable legislation.

5. Fill the heat exchanger / the system with water according to the instructions on page 12.

6. Open the ball valve for the HE supply and return flow, as well as the DHW outlet and heat up the system.

7. Check the substation and the household piping thoroughly for leaks.

8. Pressure test the entire system for leaks in accordance with the applicable regulations.

9. Connect pump and automatic components, if any, to the electricity supply, but do not switch on the power.

10. Heat the system and vent the radiator circuit/heating side thoroughly on the radiators and the air valve, if any.

11. Connection

Now switch on the pump and automatic components, if any.

12. Finish by adjusting the substation in accordance with the instruction manuals and remember to fill out the Commissioning Certificate page 31.

Note!

Heating and cooling the substation may cause leaks. Therefore it may be necessary to retighten the connections in the period after commissioning.

Note!

Never lift the station by its front insulation cover!

GETTING STARTED - VXi Solo HWP / VXi Solo H

The VXi substations offer variable connection possibilities, as connections of pipes can be established in the top or in the bottom of the substation.- Upon delivery the substation is prepared for connection in bottom of the substation. For change of connection from bottom to top, demount plugs on connection pipes in top of substation and ball valves on connection pipes in bottom of substation, and mount plugs in connection pipes. See page 10 for further information.

For connection in TOP for DCW and DHW please note that this includes relocation of the built-in blind plates BEFORE mounting the substation on the wall. (Please see instruction on page 13 for further information).

1. Mount the substation on a solid wall using two sturdy bolts (max. 8 mm), screws, expansion bolts or similar.

2. Tighten all pipe connections, as they may have loosened during transport and handling.

3. Mount the district heating meter (see page 11).

4. On systems that feature a safety valve, establish a drain connection in compliance with the applicable legislation.

5. Fill the heat exchanger / the system with water according to the instructions on page 12.

6. Open the ball valve for the HE supply and return flow and heat up the system.

7. Check the substation and the household piping thoroughly for leaks.

8. Pressure test the entire system for leaks in accordance with the applicable regulations.

9. Connect pump and automatic components, if any, to the electricity supply, but do not switch on the power.

10. Heat the system and vent the radiator circuit/heating side thoroughly on the radiators and the air valve, if any.

11. Connection

Now switch on the pump and automatic components, if any.

12. Finish by adjusting the substation in accordance with the instruction manuals and remember to fill out the Commissioning Certificate page 31.

4. MAIN COMPONENTS / CONNECTION

Akva Lux II VXi

1. Plate heat exchanger HE
2. Plate heat exchanger DHW
5. Strainer
6. Non-return valve
- 7A. Ball valve 3/4 ET/ET 120 mm for thermometer/manometer
- 7B. Ball valve 3/4 IT/ET 120 mm for thermometer
- 7C. Ball valve 3/4 ET/ET 120 mm for DVGW
8. Circulation pump, HE
11. Safety valve, HE
12. Safety valve, DHW
13. Thermometer
15. Manometer
16. Expansion vessel
- 23A. Sensor pocket 1/2"/10x1, plug M10 for heat meter
- 23B. Plugs 1/2" with O-Ring
24. Fitting piece for heat meter 3/4" x 110 mm
25. Danfoss Controller ECL 310/A337
26. Pressure independent control valve with integrated flow limiter AVQM
40. Thermostat for bypass/circulation
57. Safety thermostat Jumo AT

Accessories available as extra equipment (mounting on site)

Recirculation pipe set - Code No. 145H3879

For systems that feature domestic hot water recirculation.

KFE tap - code No. 145H3717

For filling and draining 1/4"

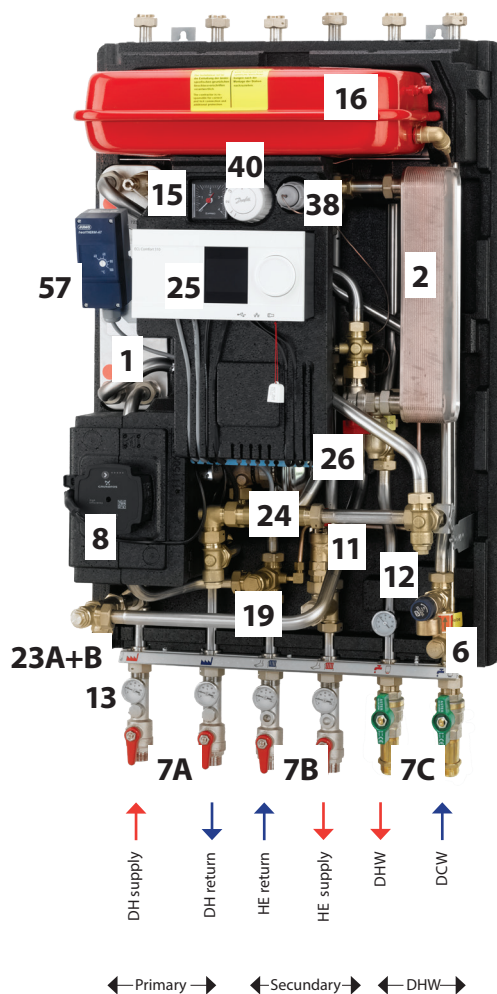

VXi Solo HWP

- 1. Plate heat exchanger HE
- 4. Differential pressure controller with flow limitation AVPB-F
- 5. Strainer
- 7A. Ball valve 3/4 ET/ET 120 mm for thermometer/manometer
- 7B. Ball valve 3/4 IT/ET 120 mm for thermometer
- 8. Circulation pump, HE
- 11. Safety valve, HE
- 13. Thermometer
- 14. Pressure relief
- 15. Manometer
- 16. Expansion vessel
- 23A. Sensor pocket 1/2"/10x1, plug M10 for heat meter
- 23B. Plug 1/2" with O-ring
- 24. Fitting piece for heat meter 3/4" x 110 mm
- 25. Danfoss Controller ECL 310/A337

Accessories available as extra equipment (mounting on site)

KFE tap - code No. 145H3717
 For filling and draining 1/4"

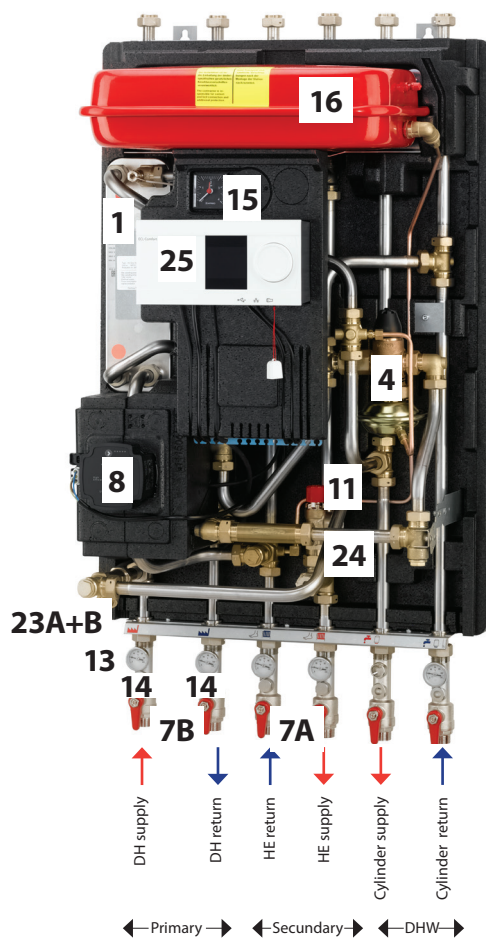

VXi Solo H

- 1. Plate heat exchanger HE
- 5. Strainer
- 7A. Ball valve 3/4 ET/ET 120 mm for thermometer/manometer
- 7B. Ball valve 3/4 IT/ET 120 mm for thermometer
- 8. Circulation pump, HE
- 11. Safety valve, HE
- 13. Thermometer
- 14. Pressure relief
- 15. Manometer
- 16. Expansion vessel
- 23A. Sensor pocket 1/2"/10x1, plug M10 for heat meter
- 23B. Plug 1/2" with O-ring
- 24. Fitting piece for heat meter 3/4" x 110 mm
- 25. Danfoss Controller ECL 310/A230
- 30. Pressure independent control valve with integrated flow limiter Danfoss AVQM

Accessories available as extra equipment (mounting on site)

KFE tap - code No. 145H3717
 For filling and draining 1/4"

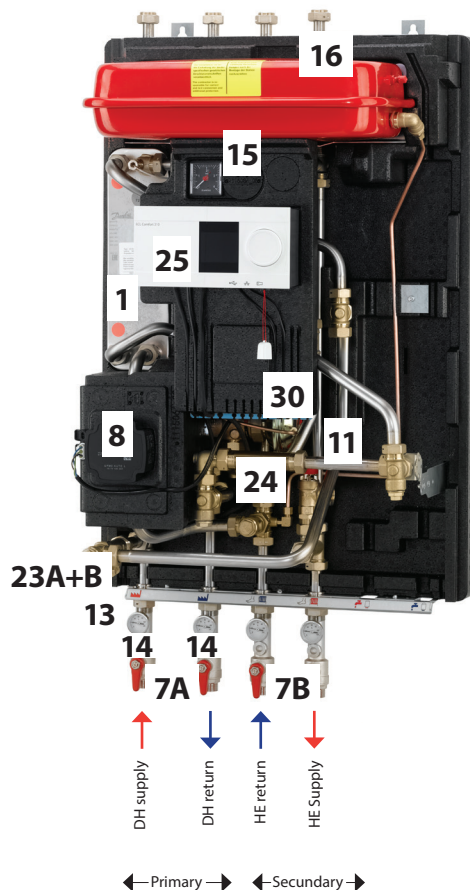

5. DIAGRAMS, DIMENSIONAL SKETCHES, EXAMPLES - AKVA LUX II VXI

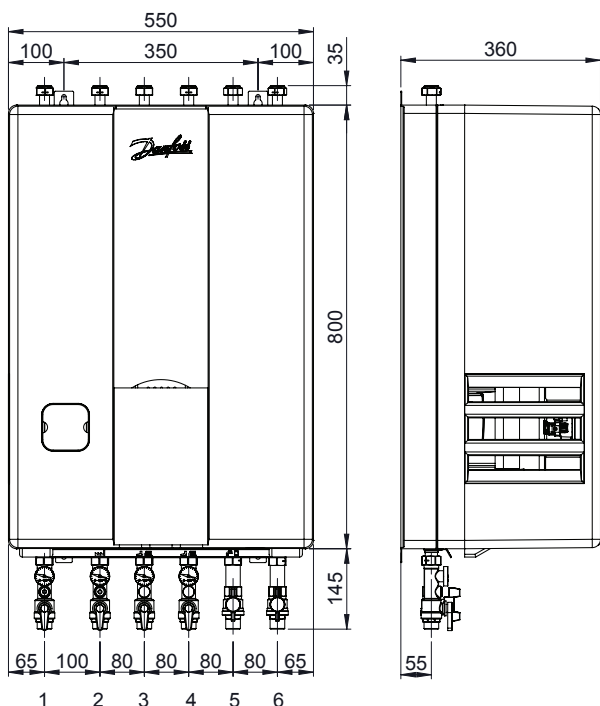
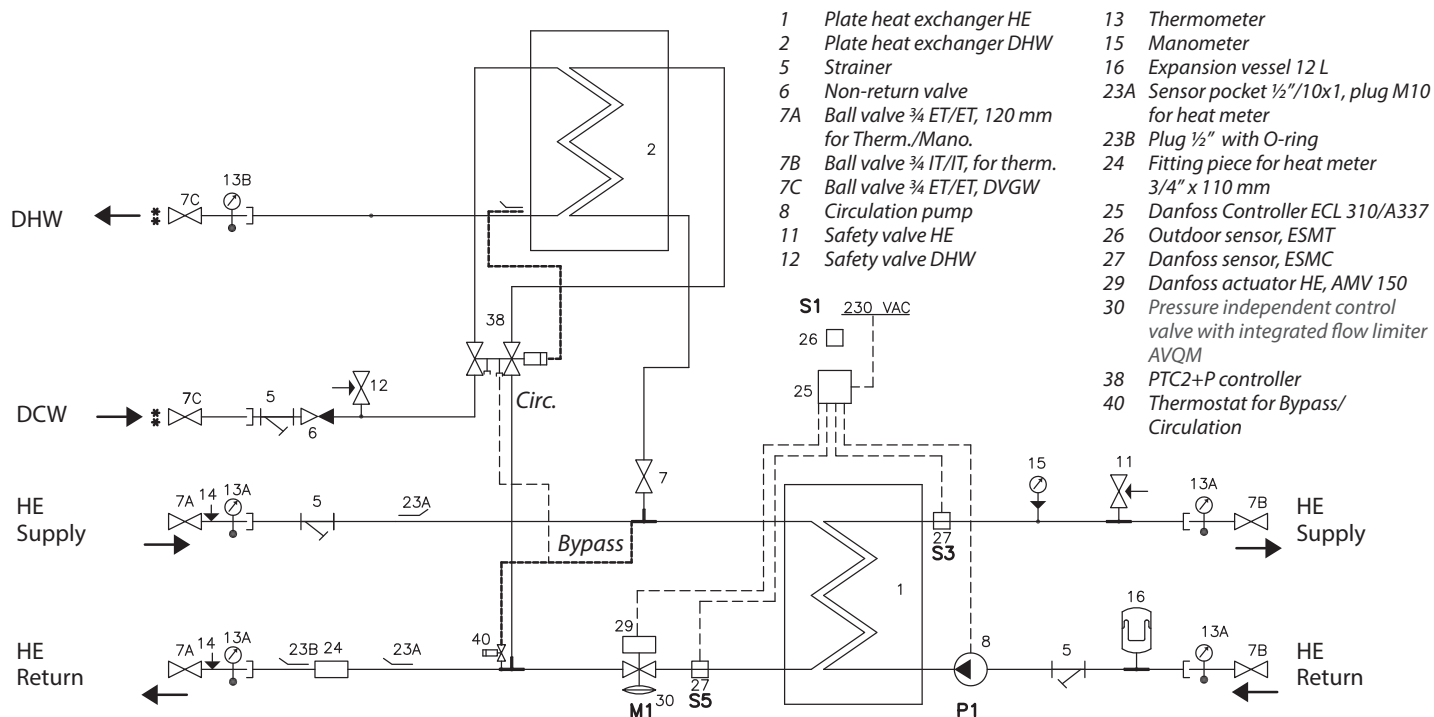

Connections:

1. District heating (DH) supply
2. District heating (DH) return
3. Heating (HE) return
4. Heating (HE) supply
5. Domestic hot water (DHW)
6. Domestic cold water (DCW)

5. DIAGRAM, DIMENSIONAL SKETCHES, EXAMPLES - VXI SOLO HWP

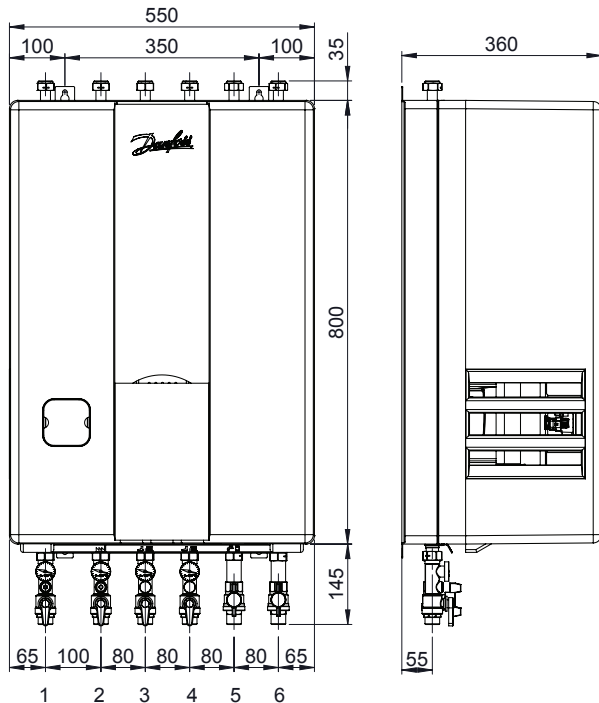
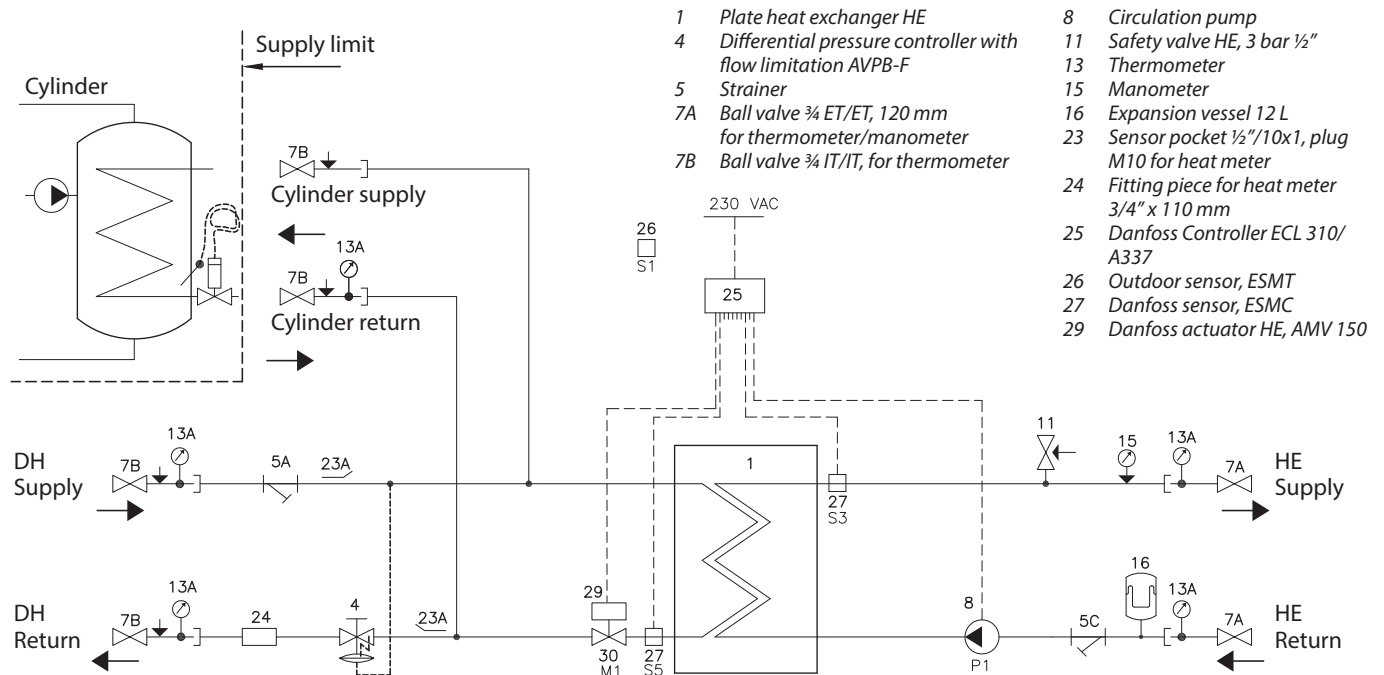

Connections:

1. District heating (DH) supply
2. District heating (DH) return
3. Heating (HE) return
4. Heating (HE) supply
5. Cylinder supply
6. Cylinder return

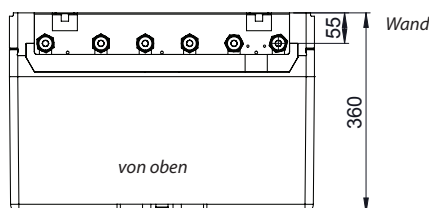

5. DIAGRAM, DIMENSIONAL SKETCHES, EXAMPLES - VXI SOLO H

- 1 Plate heat exchanger HE
- 5 Strainer
- 7A Ball valve 3/4 ET/ET, 120 mm for thermo./Mano.
- 7B Ball valve 3/4 IT/IT, for thermometer
- 8 Circulation pump
- 11 Safety valve HE, 3 bar 1/2"
- 13 Thermometer
- 15 Manometer
- 16 Expansion vessel 12 L

- 23 Sensor pocket 1/2"/10x1, plug M10 for heat meter
- 24 Fitting piece for heat meter 3/4" x 110 mm
- 25 Danfoss Controller ECL 310/A230
- 26 Outdoor sensor, ESMT
- 27 Danfoss sensor, ESMC
- 29 Danfoss actuator HE, AMV 150
- 30 Pressure independent control valve with integrated flow limiter Danfoss AVQM

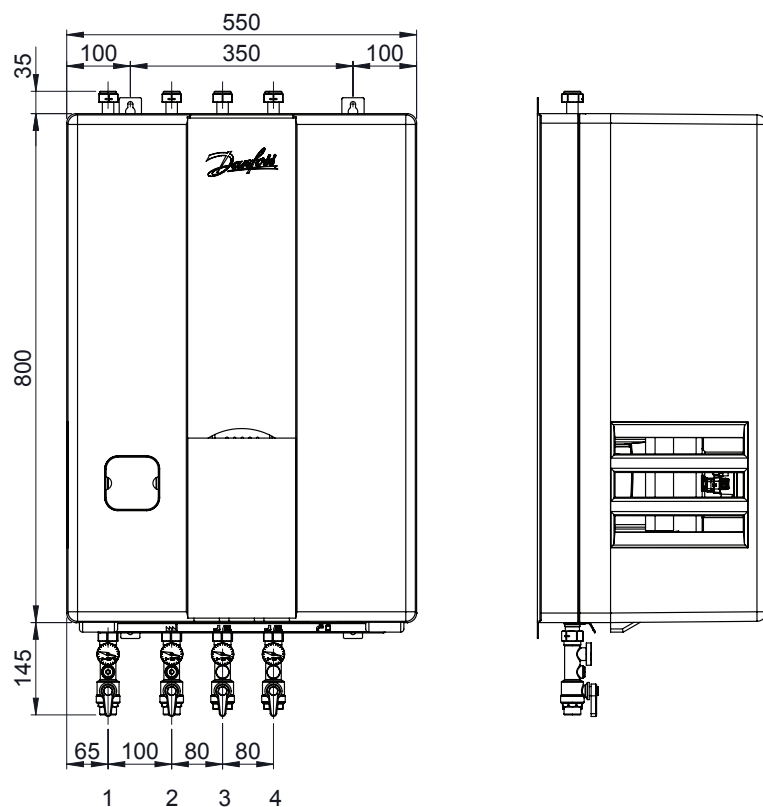
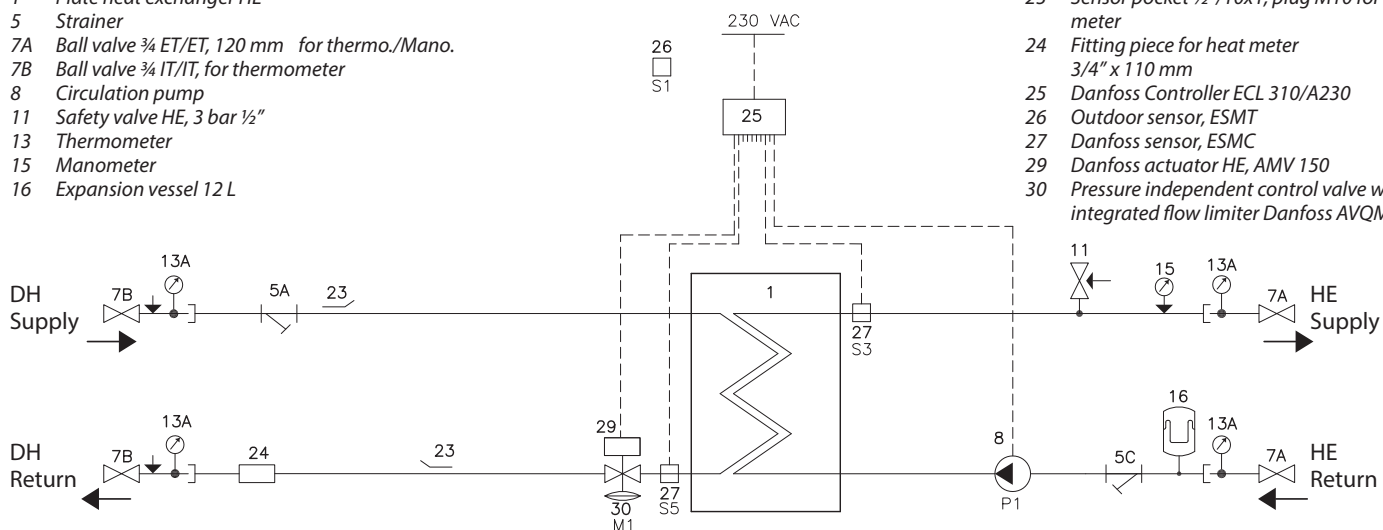

Connections:

- 1. District heating (DH) supply
- 2. District heating (DH) return
- 3. Heating (HE) return
- 4. Heating (HE) supply

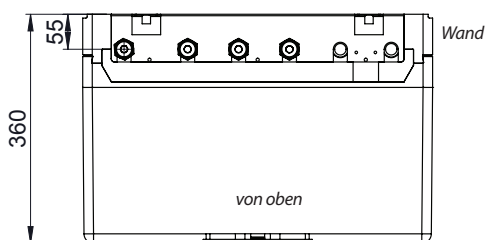

6. GENERAL, MOUNTING OF HEAT METER AND SAFETY VALVES

General

The installation, connection and maintenance of the substation must be performed by qualified and authorised personnel. Installation must always be performed in accordance with the applicable legislation and in compliance with these instructions.

The substation must be installed so that it is freely accessible and can be maintained without unnecessary disruption. Lift the substation by its mounting plate/rear section and secure it to a solid wall using 2 sturdy bolts, screws or expansion bolts positioned in the two key-holes in the mounting plate/rear section.

Before commissioning, rinse all the pipes in the household piping system thoroughly to remove any impurities, and check and clean the dirt strainers in the substation.

Connect the substation to the household piping in accordance with the labelling at the bottom and/or in accordance with the instructions in this manual.

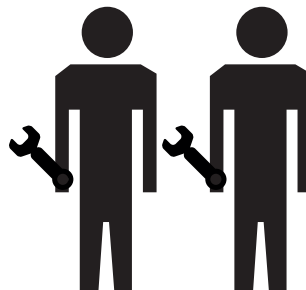

For fully insulated systems

The insulation front panel on the VXi substations can be removed without using tools. Take hold of the air duct in the top and bottom of the front insulation section and pull carefully forward until the front insulation section releases from the rear section. Then pull gently until the front section is free from the components.

Test and connections

Before filling the system with water, retighten all the pipe connections because vibrations and shocks during transport and handling may have caused leaks. Once the system has been filled with water, tighten all the pipe connections once more before performing pressure test for leaks. After heating of the system, check all the connections and retighten if necessary.

Please note that the connections may feature EPDM rubber gaskets! Therefore, it is important that you **DO NOT OVERTIGHTEN** the union nuts. Overtightening may result in leaks. Leaks caused by overtightening or failure to retighten connections are not covered by the warranty.

Heat meter, fitting pieces.

The substation is equipped with fitting pieces for heat meter on the district heating return line. (Measurement: 3/4" x 110 mm).

Fitting of heat meters

- Close the four ball valves on the district heating and the heating sides.
- Loosen the union nuts at both ends of the fitting piece (A + B) and remove it.
- Fit the heat meter, - remember to insert gaskets.
- Mount sensor, - remember to insert gaskets.
- After mounting of heat meter remember to check and tighten all pipe connections before commissioning the substation.

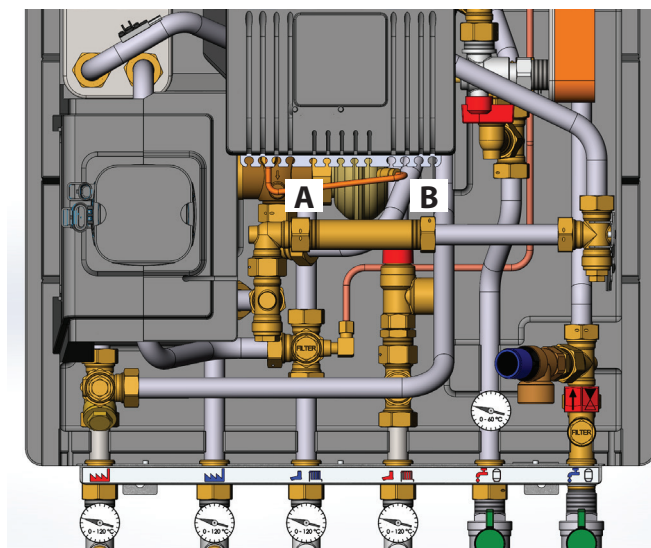

Safety valve(s)

Always lead the blow-off pipe from the safety valve to a drain in accordance with applicable legislation.

The insulation cover is be prepared for this and blow-off pipe from the safety valves are led through the slit in the insulating cover as shown in the photo to the right.

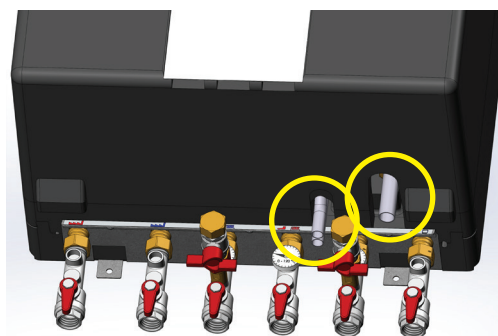

7. FILLING THE SYSTEM WITH WATER

Test and connections

Before filling the system with water, retighten all the pipe connections because vibrations and shocks during transport and handling may have caused leaks. Once the system has been filled with water, tighten all the pipe connections once more before performing pressure test for leaks. After heating of the system, check all the connections and retighten if necessary.

Please note that the connections feature EPDM rubber gaskets! Therefore, it is important that you **DO NOT OVERTIGHTEN** the union nuts. Over-tightening may result in leaks. Leaks caused by over-tightening or failure to retighten connections are not covered by the warranty.

Filling, start-up

Before filling the system with water, retighten all the pipe connections. Once the system has been filled with water, tighten all the pipe connections once more before performing pressure test for leaks. Before filling the system with water and starting-up, check if:

- pipes are connected according to the circuit diagram,
- expansion vessel is connected,
- heat meter is mounted,
- shut-off valves are closed,
- threaded and flanged connections are tightened,
- recirculation, if any, has been established.

Filling the heat exchanger / the system with water:

- The pump must be switched off when filling the system with water.
- Open the ball valves for the HE supply and return flow and fill the system with water and at the same time venting the system.
- Fill the heat exchanger / the system with water until the manometer shows a working pressure, which corresponds to the system height + approx. 5 m (approx. 1.2 - 1.5 bar).
- Finally open the remaining ball valves and heat up the system.
- After filling and heat-up of the system it should be vented by means of the air vents on the substation, if any and on the radiators.
- Then switch on the pump.

*** Note:** There is no filling valve inside the station. For refilling use a refill hose, customary for heating systems. **Filling of water to the heating system must be done outside the substation, typically by connection to a cold water supply in the household installation.**

Accessories available as extra equipment (mounting on site)

KFE tap - code No. 145H3717
For filling and emptying 1/4"

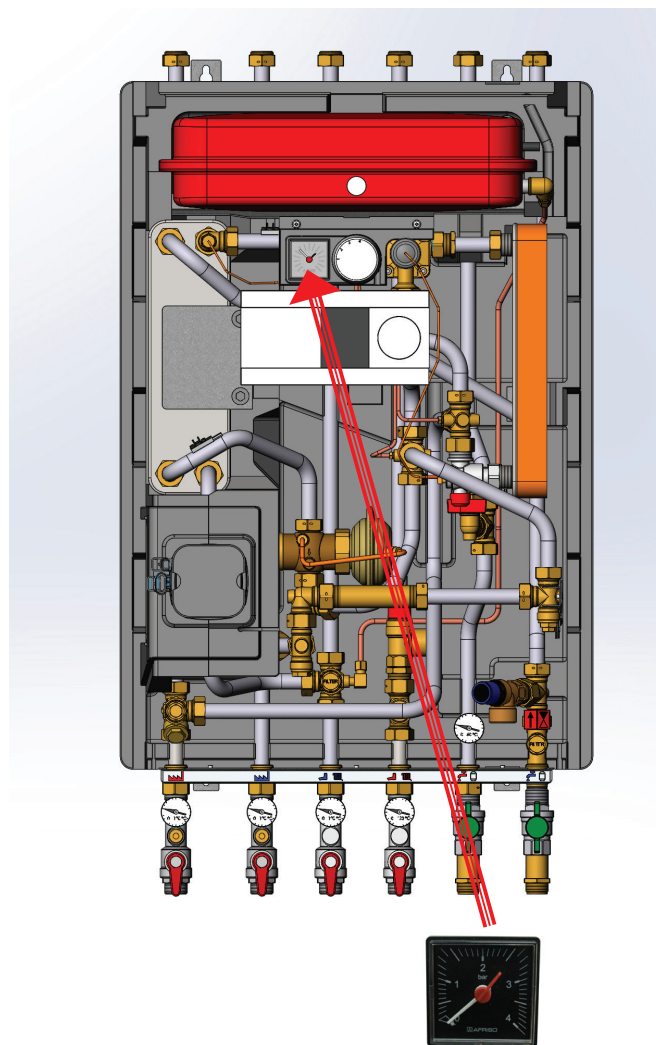

8. VARIABLE CONNECTION POSSIBILITIES

Variable connections possibilities

The VXi substations offer variable connection possibilities, as connections of pipes can be established in the top or in the bottom of the substation.

These variable connection possibilities makes it possible to establish some of the connections in the top and others in the bottom of the substation. This may be desirable in some cases.

Upon delivery the substation is prepared for connection in bottom of the substation. **Please note that the ball valves are supplied loose and must be mounted on site.**

To change the connection from the bottom to the top, demount the plugs on the connection pipes in the top of the station before installing the ball valves and install the plugs in the connection pipes at the bottom of the station.

PLEASE NOTE!

Remember to use gaskets when establishing connection in top of unit.

Heating (HE)

The unit can be connected with piping both up and down on the heating side. Remove the plugs in top of unit, and establish connection upwards. Mount the plugs in bottom connection pipes.

To change the connection from the bottom to the top, demount the plugs on the connection pipes in the top of the station before installing the ball valves and install the plugs in the connection pipes at the bottom of the station.

DCW

If there is a need for a DCW *outlet* in top of the unit, **remove** the blind plate in pos. A and demount the plug on the DCW pipe in top of the unit.

For DCW *inlet* in top of the unit, remove the plug in top of the unit and the blind plate in pos. A. Mount the ball valve in top and use the plug for plugging in the bottom (remember gaskets).

DHW

For DHW *outlet* in top of the unit, remove the blind plate and gasket in Pos. B and relocate to Pos. C - see photos to the right.

The blind plate should be installed in Pos. C to prevent a pocket of standing water that at worst can produce dangerous bacteria. Therefore, it is extremely important to install the blind plate as shown.

Also move the plug from the top connection to the DHW outlet in the bottom of the unit and mount the ball valve in top (remember gaskets).

DHW both up and down

The unit can be connected with piping both up and down for the domestic hot water. Remove blind plate in pos. B and plug in top of unit.

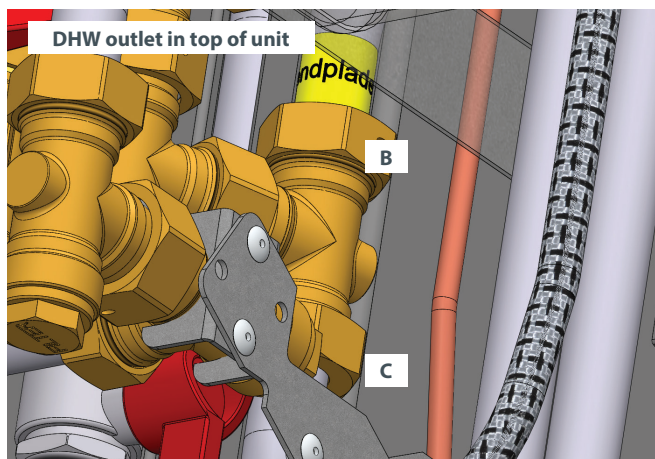
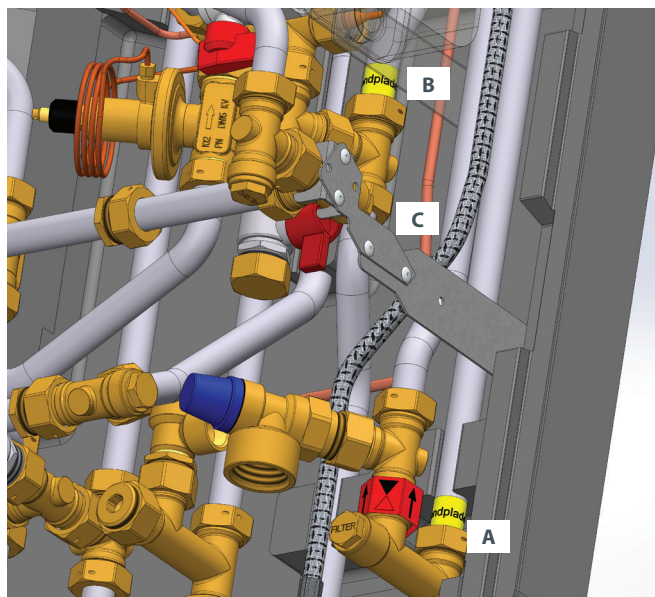
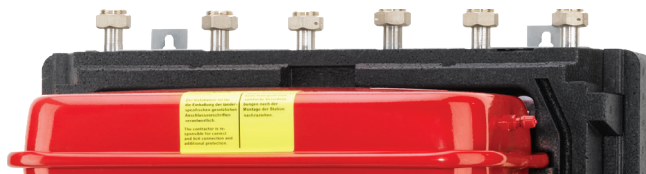

9. RECIRCULATION (ONLY AKVA LUX II VXI)

Circulation set for Akva Lux II VXi substations is available as extra equipment. The set applies to various substation types, therefore excess components may occur.

It is to be recommended to prepare the substation for recirculation BEFORE mounting it on the wall.

Fig. 1

Circulation set:

1. Sheathed steel hose
2. Capillary tube with fittings
3. Mounting bracket
4. Hexagon nipple
5. Screw plug (4 mm)

Fig. 2

Remove console (6) incl. ECL controller and meter (not shown in photo) to make room for mounting the circulation kit. The console is removed by pulling it out / up so that it comes free of bypass thermostat, manometer and domestic hot water controller. (See also page 5).

Fig. 3

Remove the nipples/plugs from the domestic hot water controller (use a 6 mm Allen key). Do not re-use the plugs!

Fig. 4

Remove the existing capillary tube between the bypass thermostat and the T-piece (marked with yellow). Use a 4 mm plug (5) to seal the T-piece.

Fig. 5

Fit/screw circulation hose end (steel hose) onto the controller (in the rear connection piece). Fit a new capillary tube (2) between the controller and the bypass thermostat.

Fig. 6 + 7

Carry the circulation hose behind and down alongside the cold water pipe as shown.

Fig. 8

Mount the supplied bracket, as shown, with two screws and secure the hose with a 1½" hexagonal nipple - thus prepared for establishing a possible circulation connection.

Fig. 9

Alternatively, connect the circulation hose at the top of the station. Cut an opening for the hose in the insulation cover. Mount the bracket as shown with two screws and secure the hose as described above.

For fully insulated systems, it is always necessary to cut an opening into the front cover for the DHW circulation.

NOTE!

Remember always to mount circulation pump and non-return valve on the circulation pipe and to mount safety valve on the DCW inlet. The pump must be installed so that the pump is pumping water towards the water heater. This not part of the circulation set.

New function (from bypass to circulation thermostat)

When the substation is connected to the household recirculation system, the thermostat will function as a circulation thermostat and control the circulation water temperature, independently of the set DHW temperature. It is recommended to set the thermostat in pos. 3.

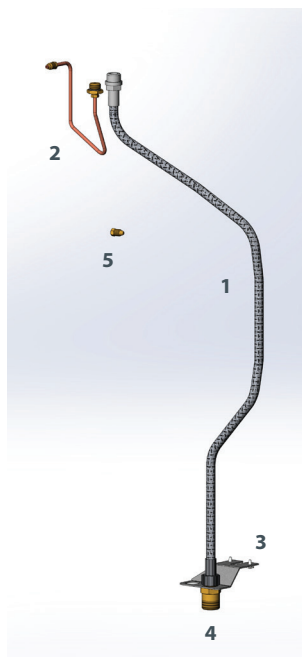

Fig. 1

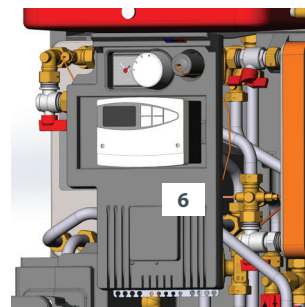

Fig. 2

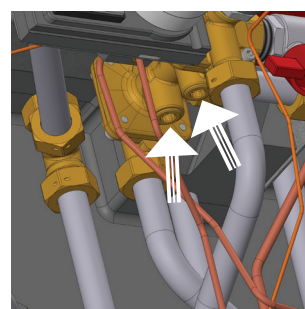

Fig. 3

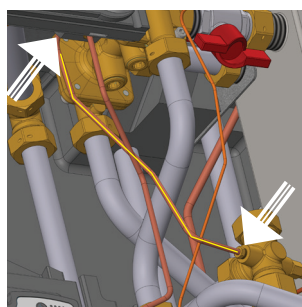

Fig. 4

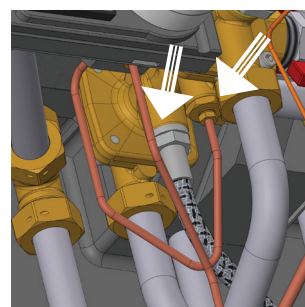

Fig. 5

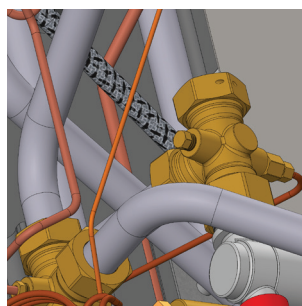

Fig. 6

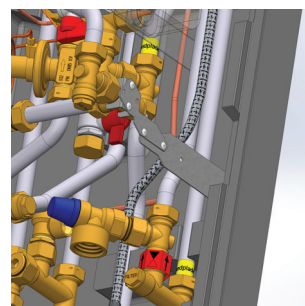

Fig. 7

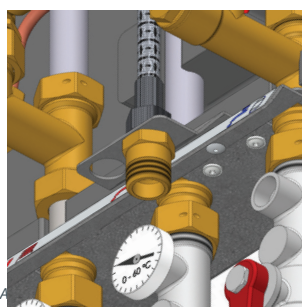

Fig. 8

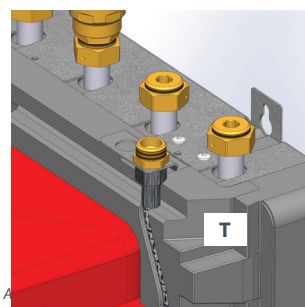

Fig. 9

10. ELECTRICAL CONNECTION

Electrical connection

The electrical connection of the substation must be performed by a qualified and authorised electrician in compliance with all applicable rules and regulations.

The station should be connected to a 230 V AC power supply.

The power supply / connection must be carried out in accordance with the applicable regulations and instructions.

The station must be wired and connected to an external main switch so that it can be disconnected during maintenance, cleaning and repairs or in the event of an emergency.

Do not forget to establish potential equalization.

The Akva Lux II VXi and VXi Solo are delivered with Danfoss ECL Comfort 210 or 310 controllers from factory.

The actuator and sensors are mounted in the station. The controller is built into the console at the top of the station.

The station is wired and tested in the factory.

Electrical connections between the controller, pump(s), sensor and actuator(s) are made.

Mounting of outdoor temperature sensor (ESMT)

The outdoor temperature sensor is delivered separately and must be mounted on site according to the enclosed illustrations.

The outdoor sensor is always to be mounted on the coldest side of the property, where it is less likely to be exposed to direct sunshine (normally the north side of the property).

The sensor must not be exposed to the morning sun, and should not be placed above windows, doors, air vents or other heat sources, and not under balconies and roof eaves.

Mounting height approx. 2.5 m above ground.

Temperature range: -50 to 50° C.

Electrical connections

The cables can be connected to the sensor in any order.

Connection cable: 2 x 0.4 - 1.5 mm²

For ECL 210 / 310:

Connect the cable ends to ECL controller in common ground terminal and in terminal 29.

Access to ECL base part

Access to the base part for connection of outdoor sensor or the like is obtained by pulling the lock (pin) down with a screwdriver until a yellow line is visible on the lock. Then, the front piece can easily be removed. Lock by pressing the lock (pin) up.

Controller ECL Comfort 210/310

Supply voltage:	230 V a.c. - 50 Hz
Voltage range:	207 bis 244 V a.c. (IEC 60038)
Power consumption:	5 VA
Load on relay outputs:	4(2) A - 230 V a.c.
Load on triac outputs:	0,2 A - 230 V a.c.

Actuator AMV13 / AMV 150

Supply voltage:	230 V a.c. - 50 Hz
Power consumption:	2 / 8 VA

For further information please see enclosed instruction manual.

Pumpe UPM3 AUTO

Supply voltage:	230 V a.c. - 50 Hz
Protection class:	IP44
Power consumption:	Max. 52 Watt

For further information please refer to the enclosed instructions for the circulation pumps.

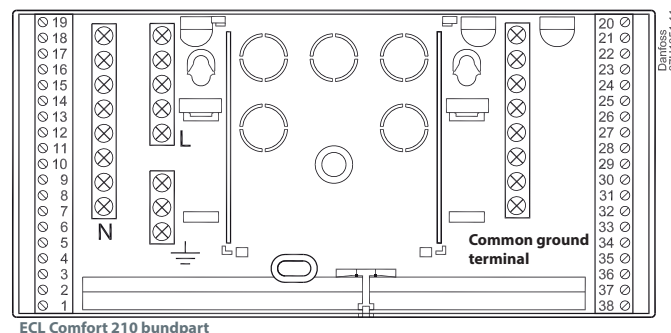
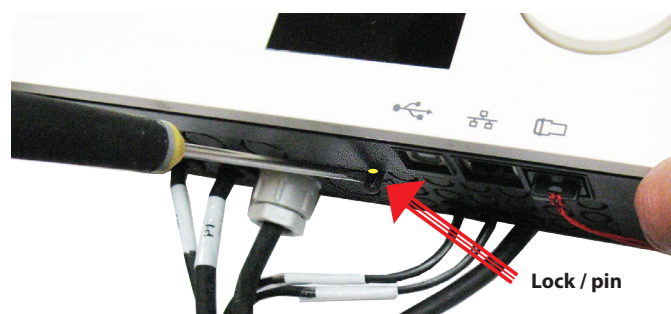
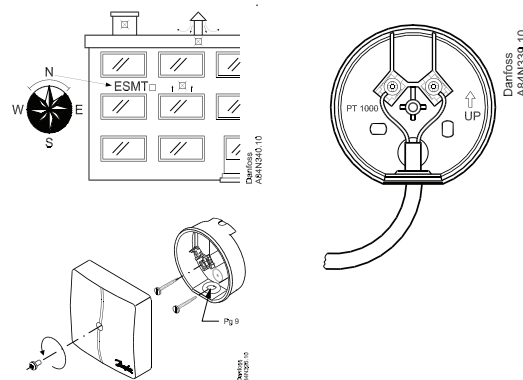

11. ADJUSTMENT AND COMMISSIONING

General information

PLEASE NOTE! Some models may have a slightly different appearance, but the control function is in principle the same as described below.

Commissioning

Commission the substation in accordance with the instructions on pages 3-12.

Filling the system / operating pressure

Fill the unit with water according to the instructions on page 9. If the pressure drops below 1 bar, water must be added to the system.

The operating pressure should never exceed 1.5 bar. (The safety valve opens at 2,5 bar)

If system pressure drops dramatically within a short time, heating system should be examined for leakage, - this includes checking the factory set pressure of the expansion vessel, which is normally 0,5 bar.

Differential pressure controller (VXi Solo HWP)

The self-acting differential pressure controller with flow limitation primarily reduces the high fluctuations in pressure in the district heating network, ensuring constant operating pressure across the substation and thereby ensures the best possible operating conditions for radiator thermostats, which enables individual control of the room temperature. The controller closes on rising differential pressure or when set max. flow is exceeded.

Control valve closes on rising differential pressure and opens on falling differential pressure to maintain constant differential pressure.

The differential pressure is preset from factory and should not be adjusted afterwards

The controller has a control valve with adjustable flow restrictor, and the flow setting is being done by the adjustment of the flow restrictor position. The adjustment can be performed on the basis of flow adjustment diagram (see relevant instructions).

The controller is equipped with excess pressure safety valve, which protects control diaphragm from too high differential pressure.

See enclosed instruction manual, AVPB-F

Differential pressure controller (Akva Lux II VXi and VXi Solo H)

For Akva Lux II VXi and VXi Solo H, the differential pressure controller is installed in the AVQM self-acting flow controller with integrated control valve. Please see page 18.

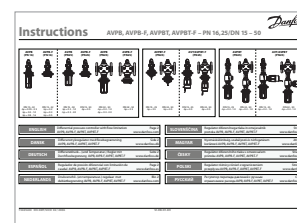
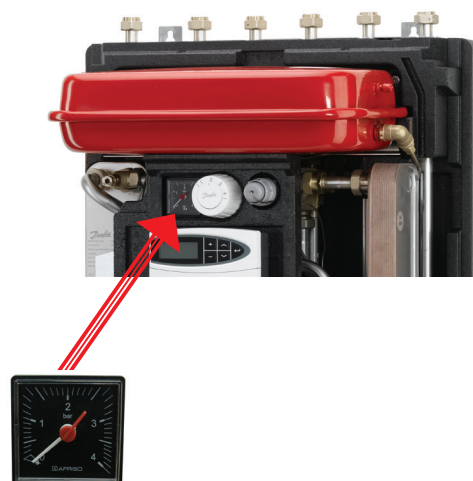

Adjustment of the flow volume

Flow setting is being done by the adjustment of the flow restrictor position.



12. HEATING CIRCUIT, DANFOSS ECL 210 / 310 AUTOMATICS

Weather-compensated control of the heating circuit

Danfoss ECL 210 / ECL 310

The temperature for the heating circuit is controlled electronically by the Danfoss ECL controller. The supply temperature is calculated by the controller on basis of the outdoor temperature.

The ECL Comfort controller is loaded with a selected application by means of an ECL Application Key (Plug-&-Play). The Application Key contains information about application, languages and factory settings. Various applications can be loaded by means of the ECL Application Key, and it is possible to update the controller with new application software.

The controller is factory preset to turn off the heating automatically in the summer period. The controller settings can be changed in accordance with the enclosed producer instructions for the mounted controller.

The controller is pre-programmed (normally) with the following factory settings:

- Language = English,
- Operating mode of the controller = Comfort "Sun" Symbol,
- Application type = A337 (Akva Lux II VXi, VXi Solo HWP)
- Application type = A230 (VXi Solo H),

Motor speed and motor protection is set and the controller is functional is functionally tested, so it's ready for use.

Start-up of ECL 210 / 310 (easy start-up)

When the outside temperature sensor is properly installed and electrically connected to the controller as described in the instructions on page 15, proceed as follows:

1. Connect the controller and switch it on,
2. Choose 'MENU' in any circuit - Confirm and turn the dial and choose 'Common controller settings' in the circuit selector at the top right corner in the display, (You navigate in the controller by turning the dial left or right to the desired position. The position indicator in the display (▶) will always show you where you are).
3. Turn dial to select time and date, Push the dial to confirm the selection
4. Select time and date,
5. The controller is now ready for use. Set heat curve and temp. max. according to the procedure described below.

Setting / change of factory settings:

6. Choose 'MENU' in any circuit - Confirm and turn the dial and choose 'Heating circuit' in the circuit selector at the top right corner in the display (radiator symbol),
7. Then turn the dial and choose 'Settings' and confirm by pushing the dial. Then choose 'Flow temperature' and here you set 'Heat curve' (value), according to the actual system type, including "Temp. max.",
8. Typical setting ranges:

Heating circuit	one-string	two-string	Floor heating
Temp. max.	70-90°C	55-65°C	35-40°C
Heat curve	1,0 - 1,75	0,8 - 1,0	0,1 - 0,5

Note: in systems that feature only floor heating the max. supply temperature must be changed according to the above mentioned information.

If increased heat demand occurs during the heating period, the controller settings can be changed

[See ECL Application Key Box with ECL Comfort 210/310 user guide and mounting guide, for further information.](#)



Turn the dial to choose 'MENU' and press to confirm selection

Home

MENU:

Time & Date

Holiday

Input overview

Log

Output override

Circuit selector

Choose this symbol to enter 'Common controller settings'

Settings

Flow temperature:

▶ Heat curve 1.0

Temp. max. 90 °C

Temp. min. 10 °C

Circuit selector

Heating circuit

Settings

Flow temperature:

▶ Heat curve 1.0

Temp. max. 90 °C

Temp. min. 10 °C

Flow temperature

Heat curve:

13. CONTROL OF HEATING CIRCUIT

Self-acting flow controller with integrated control valve and actuator Akva Lux II VXi & VXi Solo H

For controlling the heating circuit the Akva Lux II VXi and VXi Solo H are supplied with a self-acting flow controller with integrated control valve Danfoss AVQM and a Danfoss AMV actuator placed in the primary return flow line. The AMV actuator is electrically wired to the controller from the plant.

The control valve closes on rising differential pressure and opens on falling differential pressure to control max flow. The controller closes when set max. flow is exceeded.

In a combination with electrical actuators AMV and ECL electronic controllers the flow and temperature can be controlled to achieve highest energy savings. The controller is equipped with excess pressure safety valve, which protects control diaphragm for flow control from too high differential pressure.

AMV 150

The actuator has undergone a functional test and is preset from factory.

In the event of operating disturbances the actuator can be shut off manually by turning the manual override knob on top of the actuator clockwise. Please note that the knob can be "tight" to turn.

AMV 13

The actuator has undergone a functional test and is preset from factory.

Depending on the selected setting of the safety function, the AMV 13 valve is fully opened or closed when the voltage supply is switched off.

**For additional information see the enclosed manuals:
Self-acting flow controller with integrated control valve and actuator AVQM
Electronic actuator AMV 150
Electronic actuator AMV 13.**

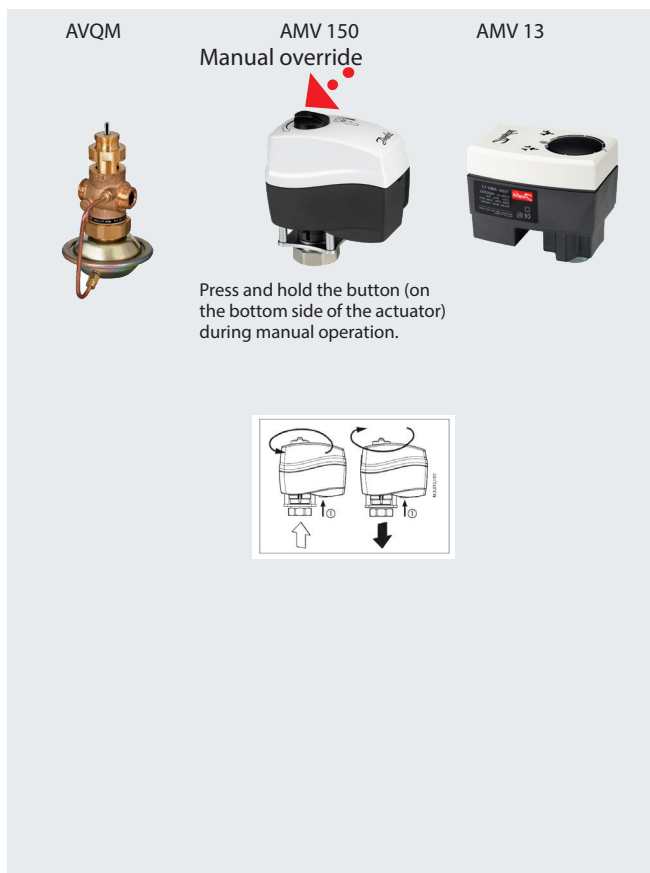

Actuator and valve, VXi Solo HWP

For controlling the heating circuit the VX Solo II HWP is supplied with a Danfoss AMV 150 or AMV 13 actuator and a Danfoss valve VS 2, placed on the primary return flow line. THE AMV actuator is electrically wired to the controller from factory.

The actuator has undergone a functional test and is preset from factory.

In the event of operating disturbances the actuator can be shut off manually by turning the manual override knob on top of the actuator clockwise. Please note that the knob can be "tight" to turn..

Depending on the selected setting of the safety function, the AMV 13 valve is fully opened or closed when the voltage supply is switched off.

**For additional information see the enclosed manuals for:
Electronic Actuator AMV 13
Danfoss Valve VS 2**

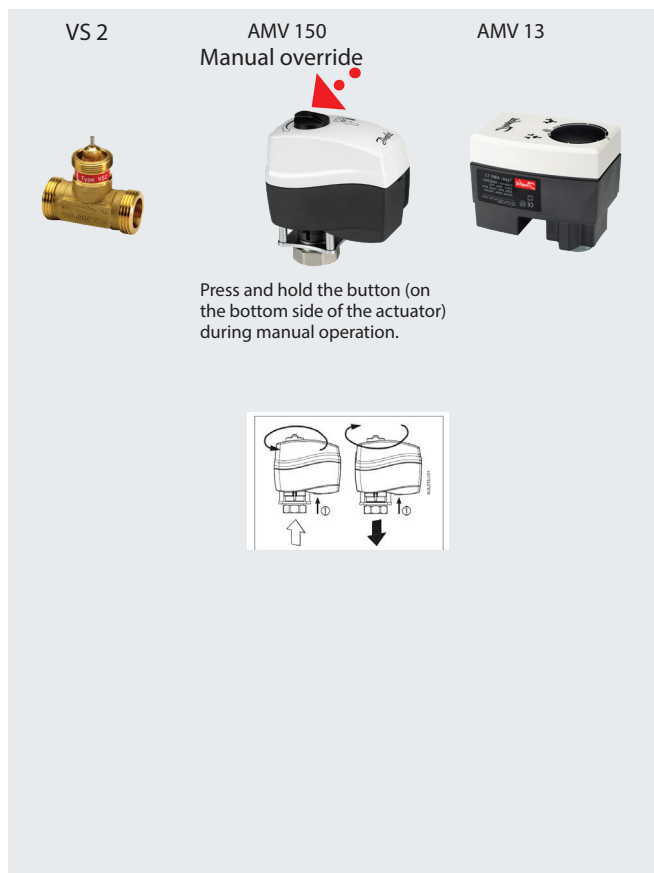

Safety function, Jumo AT

The heating circuit(s) can be supplied with a safety thermostat Jumo AT for protection against overheating.

From factory the Jumo AT safety thermostat is pre-wired to the Danfoss ECL controller with a 2 m cable, enabling the thermostat housing to be mounted in any mounting position on the household piping (HE supply) on site.

**For additional information see the enclosed manuals for:
Jumo AT**

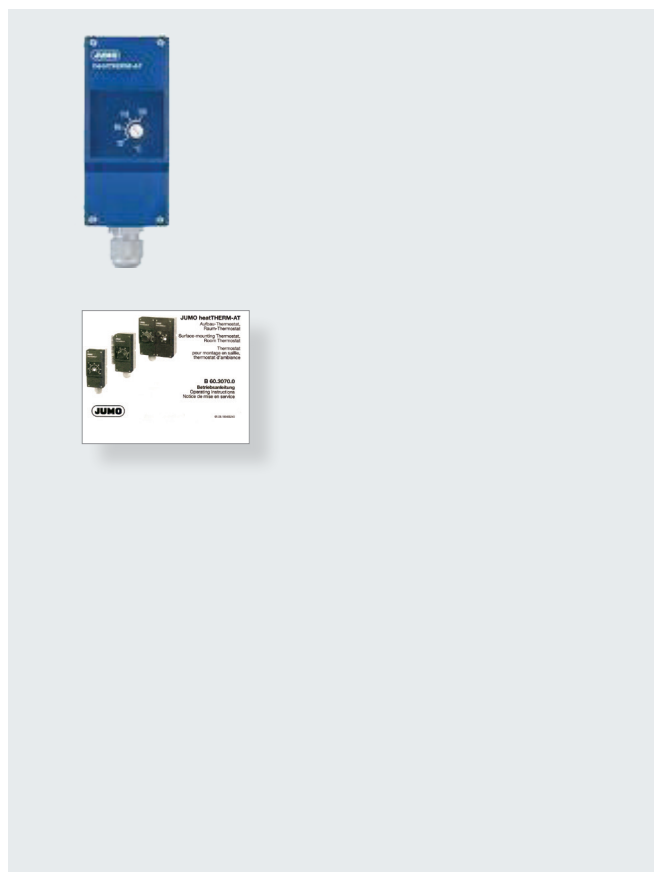

Wiring diagrams

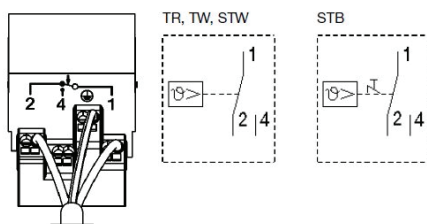

14. HEATING CIRCUIT, PUMP

Grundfos Pump UPM3 AUTO

Grundfos UPM3 Auto has 12 optional settings, which can be selected with the push-button. **See fig. 1 - User interface.**

The pump is set from factory to Proportionaldruck Pressure 2 .



Abb. 1. Bedienfeld mit einer Drucktaste und fünf LED's

The user interface shows:

- * performance view (during operation)
 - operation status
 - alarm status
- * settings view (after pressing the button)

During operation, the display shows the performance of the pump. By pressing the button, the display changes status or you can change settings.

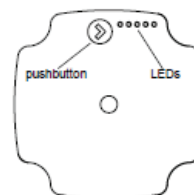

The LEDs show the power consumption for the pump. When the pump is running, LED 1 is green. The four yellow LEDs indicate the current power consumption.

See fig. 2 - Performance view.

Fig. 2. Performance view

Performance % of P ₁ max.	LED 1	LED 2	LED 3	LED 4	LED 5
0% (standby)	●				
0 - 25%	●	●			
25 - 50%	●	●	●		
50 - 75%	●	●	●	●	
75 - 100 %	●	●	●	●	●

Check the pump setting by pressing the button once (one constant pressure). The LEDs will briefly (2 sec.) show the pump setting before changing back to showing the power consumption.

See fig. 3 - Pump setting view.

If the pump setting does not give the desired distribution of heat in the rooms of the house, change the pump setting.

See fig. 3 - Pump setting view.

Before starting the setting, make clear what the display should show for the new setting (see fig. 3).

To change the pump setting, choose the setting you want (see fig. 3), press the button down for more than 2 seconds (less than 10) and the pump switches to setting selection, the LEDs start flashing and display the current setting. Then press the button until the LEDs shows the desired setting. The LEDs flash and when they stop the new setting is saved. The LEDs return to show power consumption.

Please note that if the LEDs do not flash after 2 seconds, possibly the pump setting is locked. To unlock, press the button down for more than 10 seconds. LEDs will flash and the pump is unlocked. To lock the pump, repeat the procedure.

For more information, see enclosed Grundfos instructions.



Fig. 3. Pump setting view

Funktion	Application	Pump mode				
PROPORTIONAL PRESSURE AUTO ADAPT	- Two-pipe systems	●				
CONSTANT PRESSURE AUTO ADAPT	- One-pipe systems - Floor heating		●			
PROPORTIONAL PRESSURE 1	- Two-pipe systems <i>small systems</i>	●		●		
PROPORTIONAL PRESSURE 2	- Two-pipe systems <i>middle-sized system</i>	●		●	●	
PROPORTIONAL PRESSURE 3	- Two-pipe systems <i>large systems</i>	●		●	●	●
CONSTANT PRESSURE 1	- One-pipe systems - Floor heating <i>small systems</i>		●	●		
CONSTANT PRESSURE 2	- One-pipe systems - Floor heating <i>middlesized- systems</i>		●	●	●	
CONSTANT PRESSURE 3 - MAX.	- Floor heating - One-pipe systems <i>large systems</i>		●	●	●	●
CONSTANT CURVE 1	- One-pipe systems - Charging systems <i>small systems</i>			●		
CONSTANT CURVE 2	- One-pipe systems - Charging systems <i>middle-sized systems</i>			●	●	
CONSTANT CURVE 3 - MAX.	- One-pipe systems - Charging systems - Venting of installation <i>large systems</i>			●	●	●



Alarm status

In case the 1st LED is red the pump has detected one or more alarms.

See fig. 4 - Alarm status.

When there is no active alarm anymore the user interface switches back to operation mode shortly and then showing power consumption.

Fig. 4. Alarm status

	1	2	3	4	5
Blocked	●				●
Supply voltage low	●			●	
Electrical error	●		●		

15. Domestic hot water (Akva Lux II VXi)

General information

PLEASE NOTE! Some models may have a slightly different appearance, but the control function is in principle the same as described below.

Commissioning

Commission the substation in accordance with the instructions on pages 3-12.

Regulation of domestic hot water temperature

Akva Lux II VXi

The domestic hot water is prepared in the heat exchanger based on the flow principle and the temperature is controlled by a combined hydraulic and thermostatic self-acting controller **PTC2+P** with integrated differential pressure controller, which blocks the flow of primary and secondary side flow through the heat exchanger immediately after completion of the tapping process.

PTC2 controller for DHW (Fig. 1).

Adjust the hot water temperature by moving the adjuster lever towards "+" (hotter) or "-" (colder). Start by turning the lever clockwise – until it stops/until you cannot turn it any further. Then turn the lever counter-clockwise until the temperature of the tap water is approx. 48°C during normal tapping flow (7–8 litres per min.). The temperature must never exceed 55°C to prevent limescale deposits building up in the water heater.

Bypass thermostat (default)

As a standard the substation is equipped with a bypass thermostat, Danfoss FJVR, so that when water is tapped, the water heater immediately starts to produce hot water. We recommend setting of the thermostat in pos.3. If you have to wait a long time (i.e. more than 20 sec.) for hot water, it may be necessary to set the thermostat at a higher value.

If you want to avoid waiting time altogether, you will need to set up domestic hot water recirculation to the tapping points.

Circulations thermostat / conversion to recirculation

If the household piping system features domestic hot water recirculation, the substation must be connected to the recirculation system.

Scale setting (indicative)

Pos. 2 = 30°C
3 = 40°C
 4 = 45°C

Conversion to recirculation requires only an additional circulation set. (This is not part of the delivery and must be purchased as extra equipment, - see photo on page 14).

Connect the recirculation pipe from the fixed household piping system to the hexagon nipple at the bottom of the substation (please see page 14 for instructions about how to make recirculation connection).

If a time-controlled pump is used, we recommend setting the circulation water temperature to approx. 35 °C.

Alternative controller PM2+P

As alternative the temperature can be controlled by a the pressure-controlled self-acting controller PM2+P with integrated differential pressure controller. Set the DHW temperature by turning the adjuster lever towards red (hotter) or blue (colder). Start by turning the lever clockwise - until the pin is opposite the blue dot. Then turn the lever counter-clockwise until the temperature of the tap water is approx. 48°C during normal tapping flow (7–8 litres per min.). The temperature must never exceed 55°C to prevent limescale deposits building up in the water heater. NB! The pin must be positioned between the blue and red dot, otherwise the controller will shut down.

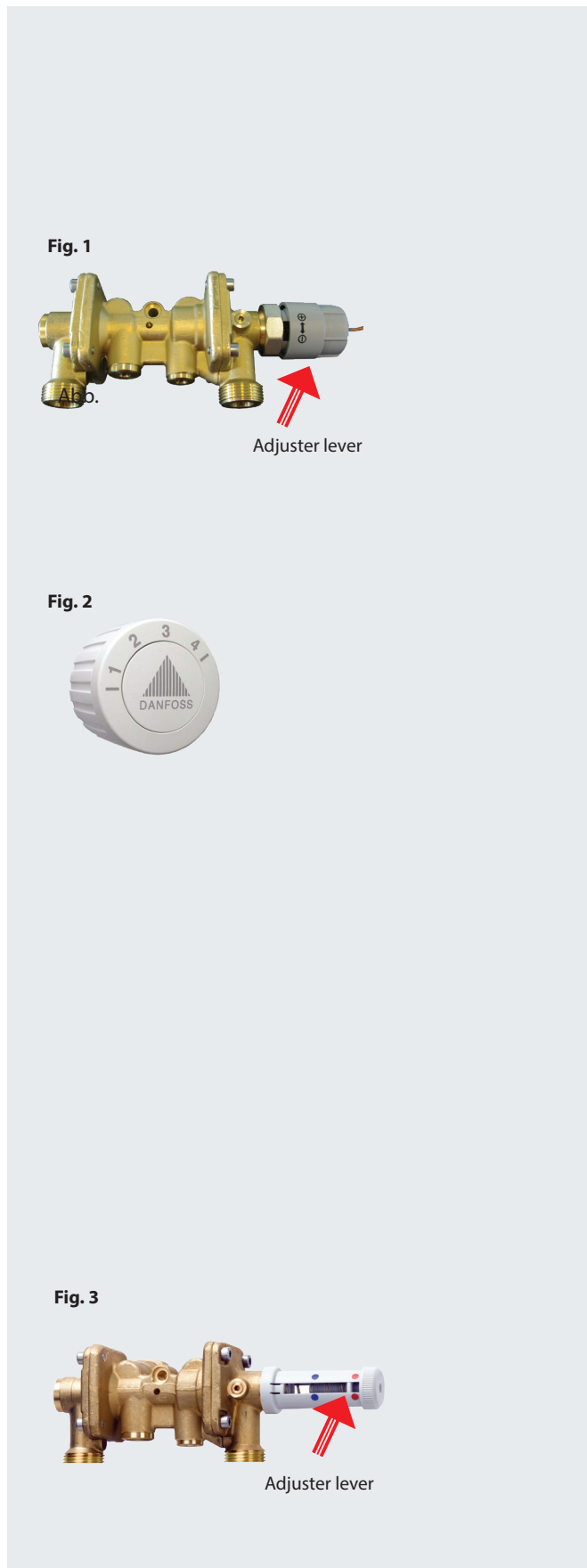

15. Domestic hot water (VXi Solo HWP)

General

The VXi Solo HWP is supplied with connection pipes for cylinder on the primary side.

Please note that domestic hot water cylinder control is not included in the standard delivery.

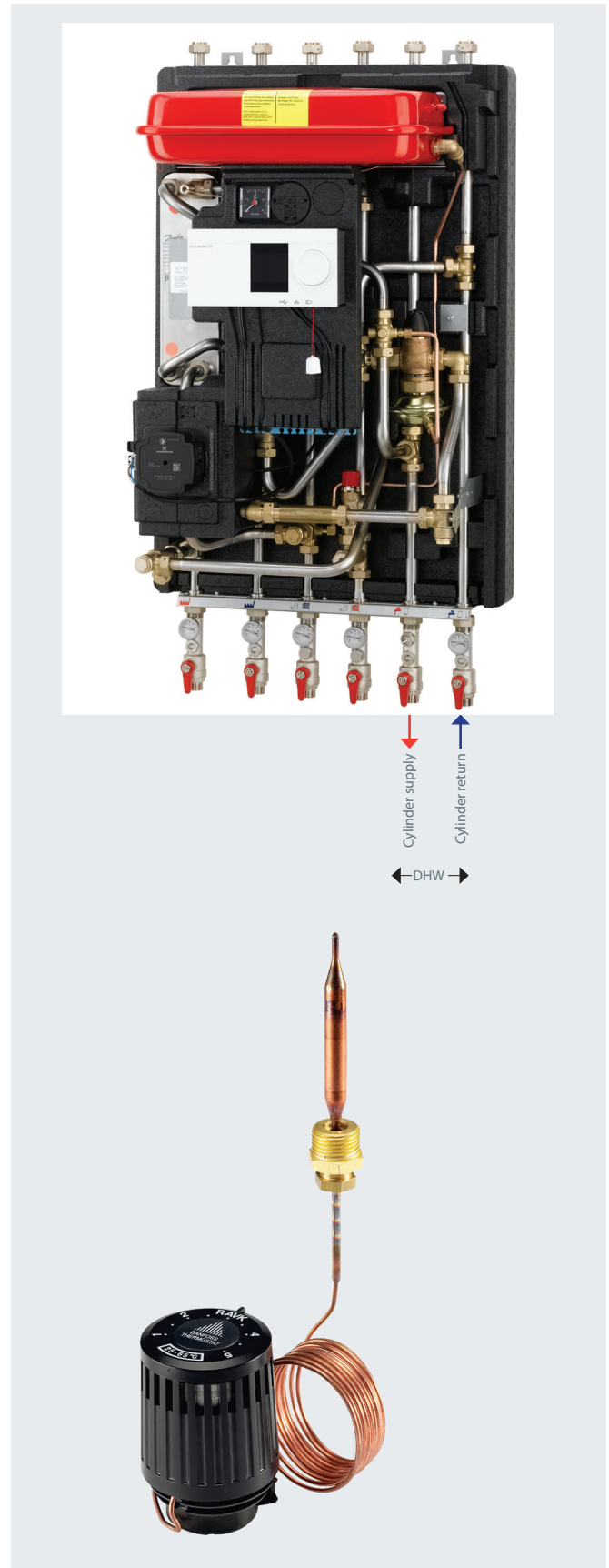

Temperature control of DHW cylinder

As an option, the VXi Solo HWP can be equipped with a RAVK self-acting thermostat and a 2-way valve VMA for temperature regulation of the DHW cylinder, - for installation outside the system. The controller closes when the temperature rises.

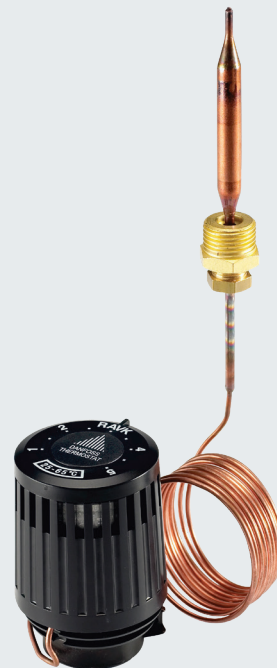
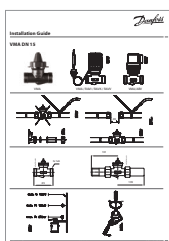
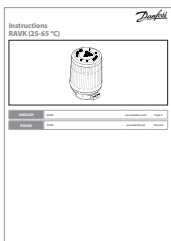

16. Maintenance

Maintenance work

Is only to be carried out by qualified and authorised personnel.

Inspection

The water heater should be checked regularly by authorised personnel. Any necessary maintenance must be performed in accordance with the instructions in this manual and other sets of instructions. During service the dirt strainers are to be cleaned – including the filter on the controller, all pipe connections must be tightened and the safety valve must be function tested by turning the lever.



Rinsing/cleaning of plate heat exchanger

To clean the plate heat exchanger, rinse it by running clean water through the exchanger at high speed and in the opposite direction to the normal flow. This will remove any dirt deposits that may have built up in the exchanger. If rinsing with clean water is not sufficient, the exchanger can also be cleaned by circulating a cleaning agent approved by Danfoss (e.g. Kaloxi or Radiner FI cleaning fluid) through the exchanger. Both these cleaning fluids are environmentally friendly and can be disposed off through the standard sewer system. After use of a cleaning fluid, the plate heat exchanger must be rinsed thoroughly with clean water.

Acid cleaning of plate heat exchanger

Deposits of limescale may build up in plate heat exchangers for domestic hot water on account of the large temperature fluctuations, and because aerated water is used on the secondary side. If it becomes necessary to clean the exchanger with acid, this can be done as shown on the drawing to the right. Brazen plate heat exchangers can withstand rinsing with a dilute acid solution - e.g. 5% formic, acetic or phosphoric acid).

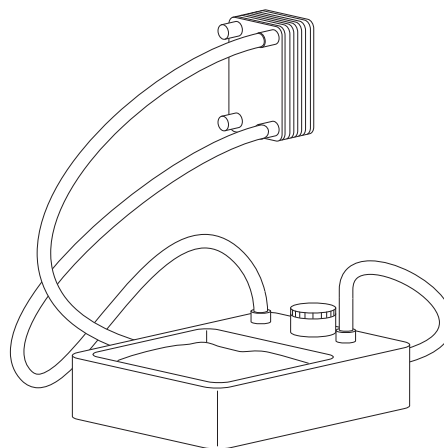

Measures after maintenance work

After maintenance work and before commissioning:

- Check that all screwed connections are tight.
- Check that all safety features, covers, that were removed, have been replaced properly.
- Clean the working area and remove any spilled materials.
- Clear all tools, materials and other equipment from the working area.
- Connect to energy supply and check for leaks.
- Vent the system.
- Carry out any necessary adjustment again.
- Make sure that all safety features on the device and the system work properly.

Meter reading

The caretaker/owner must perform visual checking and reading of the district heating meter at short, regular intervals. (The meter is not a part of the delivery from Danfoss).

Service procedures must only be performed by trained, authorised personnel.

NB! Excessive consumption for whatever reason is not covered by the Danfoss warranty.

Cooling / Return temperature reading

Cooling – i.e. the difference between the supply and return temperature of the district heating water – has a significant effect on overall energy economy. Therefore, it is important to focus on the supply and return temperature in the heating system. The difference should typically be 30–35°C. Please note that a low district heating return temperature is directly related to the return temperature from the heating circuit and the return temperature of the circulation water. It is therefore important to focus on these return temperatures.

16. Maintenance schedule (recommendations)

Interval	Maintenance work	Comments
At least once a year	Check all connections for leaks	If you identify a leak, replace the gaskets and retighten the pipe connections
	Check that the safety valve on the cold water supply is functioning correctly.	Check the functionality by turning the lever on the safety valves
	Check that all components are intact and functioning as intended	In the event of irregularities, lack of functionality or visible faults and defects in a component, replace the component in question
	Clean all dirt filters/strainers in the substation	Replace any filters that are not intact
	Check that any electrical cables are in serviceable condition and that it is possible to disconnect the electrical power supply to the substation	Visual check. Check whether it is possible to disconnect the current to the substation.
	Check the pipes and exchanger for signs of corrosion	Visual check
	Check that the insulation cover is intact	Make sure that the insulation cover encloses the substation tightly
	Check that the temperature regulators are set in accordance with the instructions in this manual	Follow the instructions in the present manual
	Check the functions of all shut-off valves	Check that the ball valves open and close as they should

*)Enduser/caretaker.

Note! After maintenance work has been carried out all gaskets HAVE to be replaced.

17. TROUBLE SHOOTING - HEATING

Fundamental

In the event of disruptions to operation, you should fundamentally - before commencing the actual troubleshooting - check whether:

- the system is correctly connected
- the district heating supply temperature is at its normal level
- the differential pressure is at its normal level. Ask your district heating supplier if necessary
- there is a power supply to the system - pump and automatics
- the dirt strainer in the district heating supply pipe is clean
- there is air in the system (if the system is vented)

Problem	Possible cause	Solution
No heat	<p>Dirt strainer in the district heating or heating return line clogged.</p> <p>Filter in district heating meter clogged.</p> <p>Defective or incorrectly set differential pressure controller.</p> <p>Air pockets in the system.</p>	<p>Clean the filter/dirt strainer.</p> <p>Clean the filter (in consultation with the district heating plant).</p> <p>Check the functions of the differential pressure controller - if necessary, clean the valve seat.</p> <p>Vent the system thoroughly - see the instructions.</p>
Uneven distribution of heat	Air pockets in the system.	Vent the system thoroughly - see the instructions.
Poor cooling	<p>Insufficient heating surface / radiators too small compared to the total heating requirement of the building.</p> <p>Poor utilisation of the existing heating surface.</p>	<p>Increase total heating surface.</p> <p>Turn on all radiators and prevent the radiators in the system from becoming warm at the bottom.</p>
No heat	<p>Defective thermostat (sensor).</p> <p>Defective actuator - or possibly dirt in the valve housing.</p> <p>Automatic components/controller incorrectly adjusted or defective - or possibly power outage.</p> <p>The pump is not working.</p> <p>The pump is set at too low speed of rotation (not all system types).</p> <p>Air pockets in the system.</p>	<p>Replace sensor.</p> <p>Check that the actor is functioning correctly - clean the valve seat if necessary.</p> <p>Check that the controller setting is correct - see the separate instructions for the controller.</p> <p>Check the power supply.</p> <p>Temporarily set the actuator to "manual" control - see the instructions for the heating system.</p> <p>Check that there is a power supply for the pump, and that it is operating.</p> <p>Check that there is no air in the pump housing - see pump manual.</p> <p>Set the pump to a higher speed - see the instructions for the heating system.</p> <p>Vent the installation thoroughly - see the instructions.</p>

17. TROUBLE SHOOTING - DOMESTIC HOT WATER

Fundamental

In the event of disruptions to operation, you should fundamentally - before commencing the actual troubleshooting - check whether:

- the system is correctly connected
- the district heating supply temperature is at its normal level
- the differential pressure is at its normal level. Ask your district heating supplier if necessary
- there is a power supply to the system - pump and automatics
- the dirt strainer in the district heating supply pipe is clean
- there is air in the system (if the system is vented)

Problem	Possible cause	Solution
DHW*, no hot water	Non-return valve in the circulation pipe defective (leads to mixing - the circulation water pipes become cold during tapping).	Replace the non-return valve.
Temperature too low / variations in temperature	Non-return valve in thermostatic mixer in the bathroom defective - results in hot and cold water mixing. Please note that fluctuating temperatures may occur at other tapping points in the system! NB, Check all mixers in the house for faults/defects!	Replace the mixer or perhaps only the non-return valve.
Lack of hot water pressure	Clogged strainer in the cold water meter or possibly in the cold water supply in the unit. Calified heat exchanger.	Clean the strainer (cold water meter, in consultation with the water supply company). Replace the heat exchanger.
Long wait for hot water	Circulation pump out of order.	Check whether the pump is running - and whether there is a power supply to the pump. Make sure that there is no air in the pump housing.
No hot water	Dirt strainer in the district heating supply line clogged. Defective DHW controller. Defective sensor. (PTC2)	Clean the dirt strainer. Check controller settings. You may contact Danfoss Redan A/S for further information. Replace sensor.
Hot water temperature too low	As above. Non-return valve in the circulation pipe defective (leads to mixing - the circulation water pipes become cold during).	As above. Replace non-return valve.
Hot water temperature too high	Defective domestic hot water controller.	Check the function of the DHW controller and replace if defective.
Temperature falls during tapping (lack of capacity)	Air in the capillary tube for the differential pressure controller. Calified plate heat exchanger.	Vent the capillary pipe. Replace the plate heat exchanger.

Systems with DHW cylinder

Problem	Possible cause	Solution
Poor cooling	Calified heat exchanger.	Clean DHW cylinder with acid solution or replace heating element. You may check the specifications of the manufacturer conc. cylinder capacity.
Temperature falls during tapping (lack of capacity)	The immersion sensor incorrectly fitted in the cylinder.	Place sensor correctly in accordance with the cylinder manufacturer's specifications. You may contact Danfoss Redan A/S for further information.
	Calified heat exchanger.	Clean DHW cylinder with acid solution or replace heating element.
Domestic hot water temperature too high	Defective immersion sensor.	Replace immersion sensor.
No domestic hot water	Calified heat exchanger.	Clean DHW cylinder with acid solution or replace heating element.
	Inadequate cylinder capacity.	Wait for heating / loading of the cylinder. You may check the specifications of the manufacturer conc. cylinder capacity.

18. EU DECLARATION OF CONFORMITY

ENGINEERING
TOMORROW



Danfoss A/S

6430 Nordborg
Denmark
CVR nr.: 20 16 57 15

Telephone: +45 7488 2222
Fax: +45 7449 0949

EU DECLARATION OF CONFORMITY

Danfoss A/S

Danfoss Redan

declares under our sole responsibility that the

Product category:

Small substations with electrical equipment

Type designation(s):

VX 22, S 22 and VX Solo 22

Akva Vita TD, Akva Vita TDP, Akva Vita S and Akva Vita VX,

Akva Lux TD, Akva Lux TDP and Akva Lux S,

Akva Lux II S-unit and Akva Lux II VX/VXi,

Akva Les II S-unit and Akva Les II VX/VXi,

Akva Lux Se and VXe

VX2000 and Akva Lux II VX-F

Akva lux II TDP-F, Akva Lux II S-F, Complete S-F,

EvoFlat FSS, EvoFlat MSS and EvoFlat Four Pipe

Akva Therm 22, 28, 35, and Akva Therm LV

Distribution module GI, GRI, SGC and SGTZC

OEM Shunt

Covered by this declaration is in conformity with the following directive(s), standard(s) or other normative document(s), provided that the product is used in accordance with our instructions.

Machinery Directive 2006/42/EC

EN 60204-1:2006/A1:2009. Safety of machinery – Part 1 – General Requirements.

EN 12100:2010, Safety of machinery – Risk assessment.

<p>Date: 2021.03.22 Place of issue: Silkeborg</p>	<p>Issued by</p> <p>Signature: </p> <p>Name: Jan Bennetsen Title: Engineering Specialist</p>	<p>Date: 2021.03.22 Place of issue: Silkeborg</p>	<p>Approved by</p> <p>Signature: </p> <p>Name: Henrik Ellegaard Title: Quality and EHS Supervisor</p>
---	--	---	---

Danfoss only vouches for the correctness of the English version of this declaration. In the event of the declaration being translated into any other language, the translator concerned shall be liable for the correctness of the translation

19. COMMISSIONING CERTIFICATE

The substation is the direct link between the district heating supply network and the household piping system. All supply pipes and the pipes in the household piping system must be checked and rinsed before commissioning. Once the system has been filled with water, all pipe connections must be retightened before performing pressure test for leaks. The dirt strainers must be cleaned and the substation must be adjusted in accordance with the instructions in this manual.

It is important to comply with all technical regulations and the applicable legislation in every respect.

Installation and commissioning must only be performed by trained, authorised personnel.

The substation is checked in the factory for leaks before delivery. Leaks are however possible due to vibrations caused by transport, handling and heating of the system and therefore it is important to check all connections and to retighten if necessary before commissioning. Please note that the connections may feature EPDM gaskets! **Therefore it is important that you DO NOT OVER-TIGHTEN the connections.** Over-tightening may result in leaks. Leaks caused by over-tightening or failure to retighten connections are not covered by the warranty.

To be filled-out by the installer

This substation has been retightened, adjusted and commissioned

on the: _____
Date/Year

by installer: _____
Company name (stamp)

20. GUIDELINES FOR WATER QUALITY IN DANFOSS BRAZED HEAT EXCHANGERS

ENGINEERING
TOMORROW



Danfoss A/S
Danfoss Heating Segment - DEN
BU HEX - Local Inspection Center Kamnik Slovenia

Guidelines for water quality in Danfoss brazed heat exchangers with plates of EN 1.4404 ~ AISI 316L

Danfoss has prepared this guideline for the water quality of tap water and district heating water used in plate heat exchangers of stainless steel (EN 1.4404 ~ AISI 316L) brazed with pure copper (Cu), copper -nickel (CuNi) or Stainless Steel (StS). It is important to point out that the water specification is not a guarantee against corrosion, but it must be considered as a tool to avoid the most critical water applications.

Parameter	Unit	Value or concentration	Plate	Brazing material		
			AISI 316L W.Nr. 1.4404	Cu	CuNi	StS
pH		< 6.0	o	-	-	o
		6.0 – 7.5	+	o/-	o	+
		7.5 – 10.5	+	+	+	+
		>10.5	+	o	o	+
Conductivity	µS/cm	<10	+	+	+	+
		10 – 500	+	+	+	+
		500 – 1000	+	o	+	+
		>1000	+	-	o	+
Free Chlorine	mg/l	<0.5	+	+	+	+
		0.5 – 1	o	+	+	+
		1 – 5	-	o	o	o
		>5	-	-	-	-
Ammonia (NH ₃ , NH ₄ ⁺)	mg/l	<2	+	+	+	+
		2 – 20	+	o	o	+
		>20	+	-	-	+
Alkalinity (HCO ₃ ⁻)	mg/l	<60	+	+	+	+
		60 – 300	+	+	+	+
		>300	+	o	+	+
Sulphate (SO ₄ ²⁻)	mg/l	<100	+	+	+	+
		100 – 300	+	o/-	o	+
		>300	+	-	-	+
HCO ₃ ⁻ / SO ₄ ²⁻	mg/l	>1.5	+	+	+	+
		<1.5	+	o/-	o	+
Nitrate (NO ₃)	mg/l	<100	+	+	+	+
		>100	+	o	+	+
Manganese (Mn)	mg/l	<0.1	+	+	+	+
		>0.1	+	o	o	+
Iron (Fe)	mg/l	<0.2	+	+	+	+
		>0.2	+	o	+	+
* Hardness ratio [Ca ²⁺ , Mg ²⁺]/[HCO ₃ ⁻]	/	0 – 0.3	+	-	-	+
		0.3 – 0.5	+	o/-	+	+
		>0.5	+	+	+	+

+	Good corrosion resistance
o	**Corrosion could happen when more parameters are evaluated with o
o/-	Risk of corrosion
-	Use is not recommended

* Hardness ration limits defined per experience and internal tests in Danfoss laboratory

** In case of three or more parameters evaluated with o consultancy is needed with Consultant for Corrosion & Microbiology or BU HHE Representative

Recommended Chloride concentration to avoid Stress Corrosion Cracking (SCC) in the stainless-steel plates:

Application temperature	Chloride concentration
at T ≤ 20°C	max 1000 mg/l
at T ≤ 50°C	max 400 mg/l
at T ≤ 80°C	max 200 mg/l
at T ≥ 100°C	max 100 mg/l



ENGINEERING
TOMORROW

Danfoss

Danfoss A/S

Heating Segment • danfoss.com • +45 7488 2222 • E-Mail: heating@danfoss.com

Danfoss can accept no responsibility for possible errors in catalogues, brochures and other printed material. Danfoss reserves the right to alter its products without notice. This also applies to products already on order provided that such alterations can be made without subsequential changes being necessary in specifications already agreed. All trademarks in this material are property of the respective companies. Danfoss and the Danfoss logotype are trademarks of Danfoss A/S. All rights reserved.
