

iC7 Series Air-cooled Common-mode Filter OFXC1

1 Overview

1.1 Common-mode Filter

The Common-mode Filter reduces bearing and ground currents, and high frequency noise in the motor cables. There are 3 sizes of the filter with 3, 4, or 5 cores. The filter is suitable for IP00 and IP54 installation.

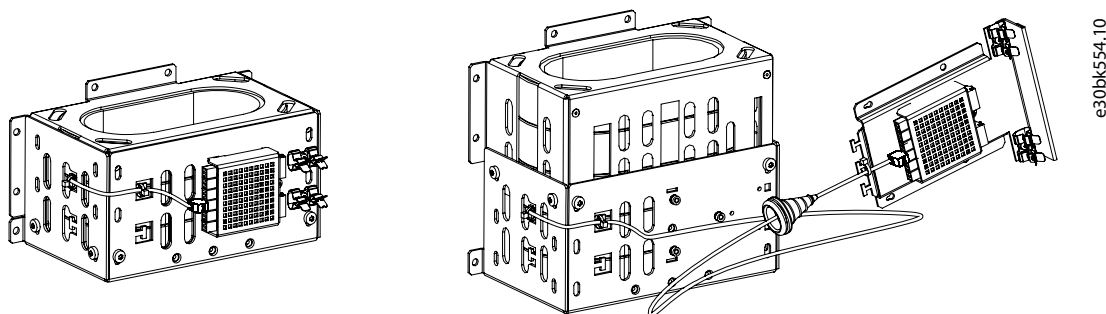

Illustration 1: Common-mode Filter with 3 Cores (IP00 Installation) and with 5 Cores (IP54 Installation)

1.2 Contents of the Delivery

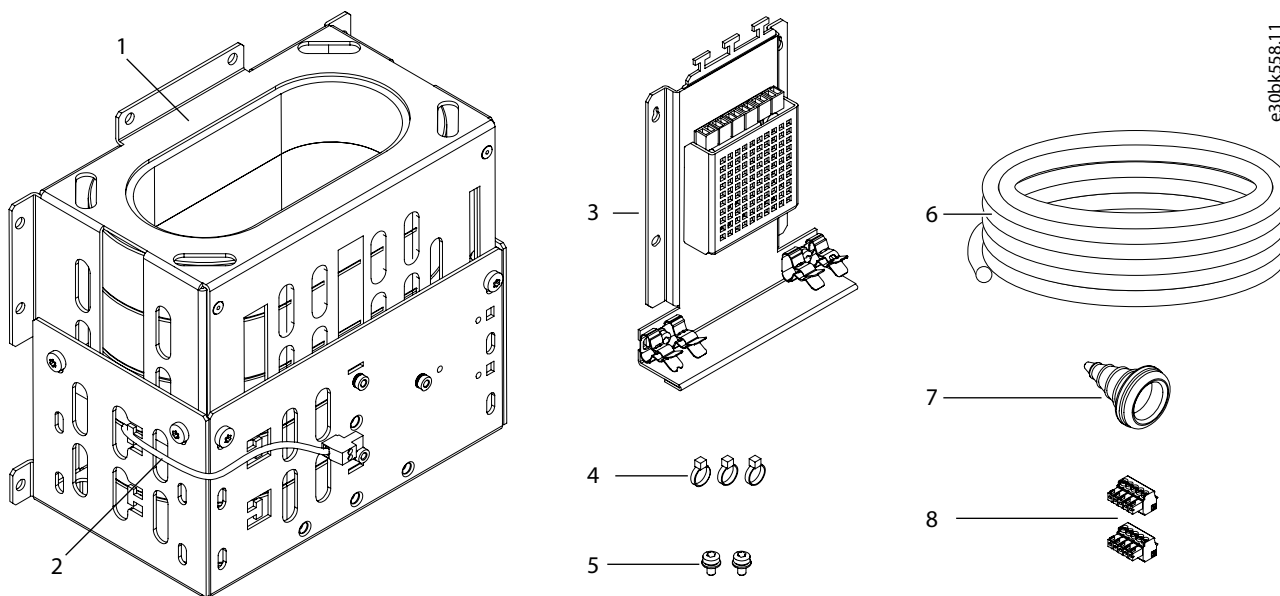

Illustration 2: Items Included in the Delivery

1	Common-mode Filter	5	M5x10 screws, 2 pcs
2	Temperature measurement wire, 1.5 m (4.9 ft), mounted	6	AuxBus cable, 3 m (9.8 ft)
3	AuxBus temperature measurement board assembly	7	Grommet, Ø25.3 mm (Ø1 in)
4	Cable ties, 3 pcs	8	AuxBus terminals, 2 pcs

2 Mechanical Installation

2.1 Safety Information

⚠ WARNING ⚠

SHOCK HAZARD FROM THE COMPONENTS

The components of the drive are live when the drive is connected to mains.

- Do not make changes in the AC drive when it is connected to mains.

⚠ CAUTION ⚠

BURN HAZARD

The filter is hot during operation.

- Do not install the filter on a combustible surface.
- Do not touch the filter when hot.

Only qualified personnel are allowed to perform the installation described in this guide.

Follow the instructions in this guide and relevant local regulations.

Also read the instructions and safety information in the operating guide for the iC7 Series System Modules.

2.2 Installation Requirements

The products that are described in this guide have the protection rating IP00/UL Open Type. Install them in a cabinet or other enclosure that has a correct level of protection against the ambient conditions in the installation area. Make sure that the cabinet gives protection against water, humidity, dust, and other contaminations.

The cabinet must also be sufficiently strong for the weight of the system modules and other devices.

The protection rating of the cabinet must be at least IP21/UL Type 1. When preparing the installation, obey the local regulations.

2.3 Installing the Common-mode Filter into the Cabinet

See the installation dimension in [2.6 Dimensions of the Common-mode Filter](#).

Procedure

1. Attach the Common-mode Filter to the cabinet using the Ø6 mm (Ø0.24 in) mounting holes.

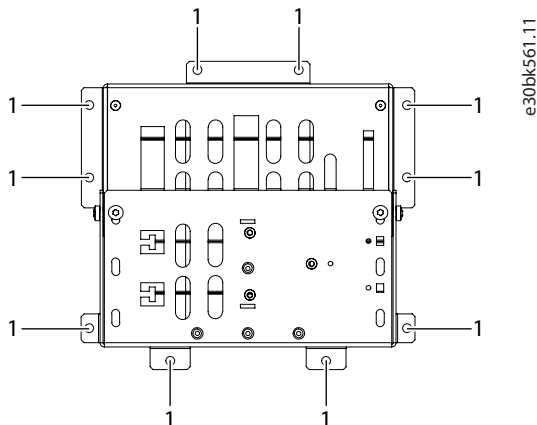

Illustration 3: Mounting Holes of the Common-mode Filter

1	Mounting holes
---	----------------

2. In IP54 installations, attach the assembly plate of the AuxBus temperature measurement board to the cabinet, but outside the IP54 section. Mount the assembly plate with 4 screws.

See [Illustration 5](#).

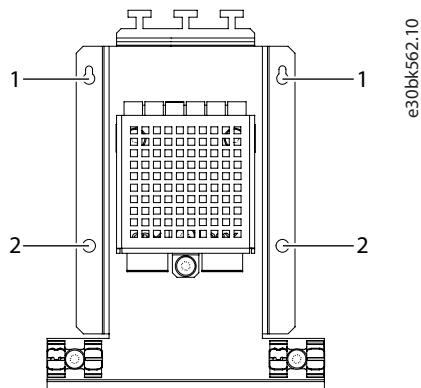

Illustration 4: Mounting Holes of the Assembly Plate

1	Mounting holes with keyholes, Ø5/3
2	Mounting holes, Ø5.5

3. Connect the temperature measurement wire from the filter to terminal X204 on the AuxBus temperature measurement board.

The length of the wire is 1.5 m (4.9 ft). If necessary, the wire can be cut shorter. Route the wire through the grommet included in the delivery. Attach the wire to the assembly plate with a cable tie.

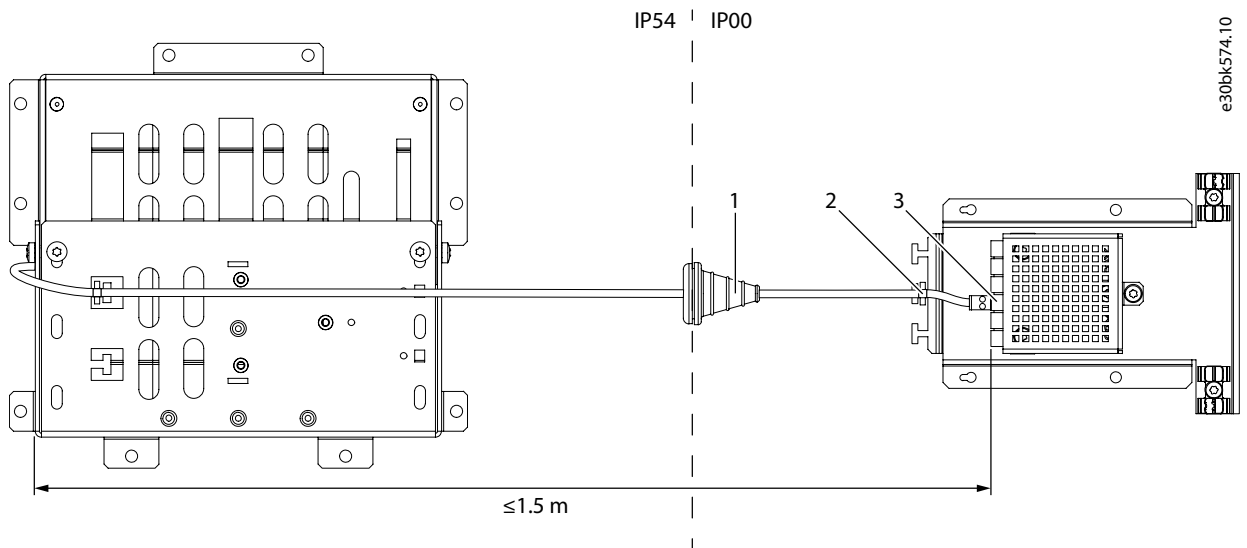

Illustration 5: Connecting and Routing of the Temperature Measurement Wire

1	Grommet	3	Terminal X204
2	Cable tie		

2.4 Installing the AuxBus Temperature Measurement Board on the Common-mode Filter, IP00

Optionally in IP00 installations, the AuxBus temperature measurement board can be mounted on the Common-mode Filter. Before mounting the AuxBus temperature measurement board on the Common-mode Filter, the AuxBus temperature measurement board assembly must be disassembled.

Procedure

1. Remove the touch cover of the AuxBus temperature measurement board by removing the M4x8 screw. Save the screw.

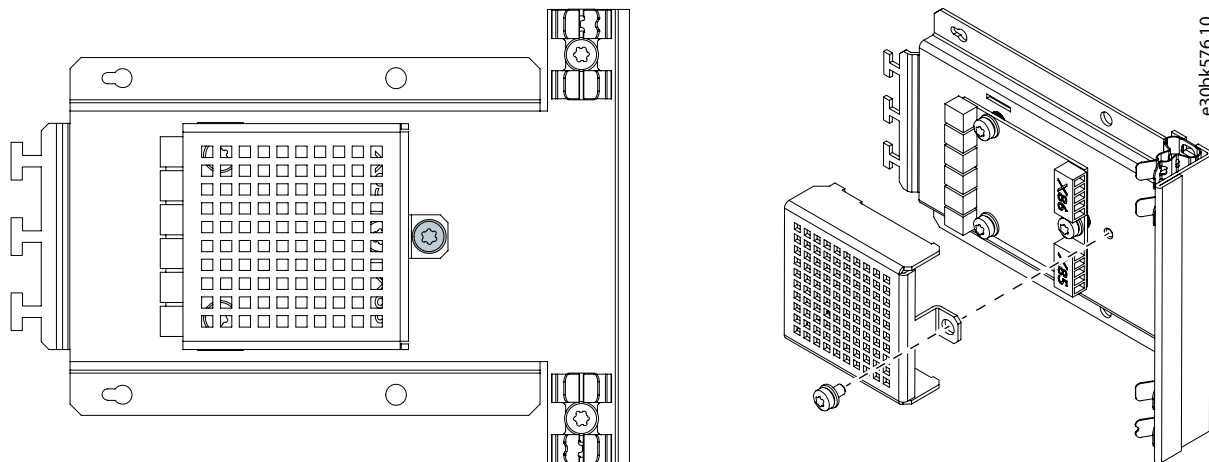

Illustration 6: Removing the Touch Cover

2. Remove the 2 cable clamps from the assembly plate by removing the 2 size M4x8 screws. Save the screws.

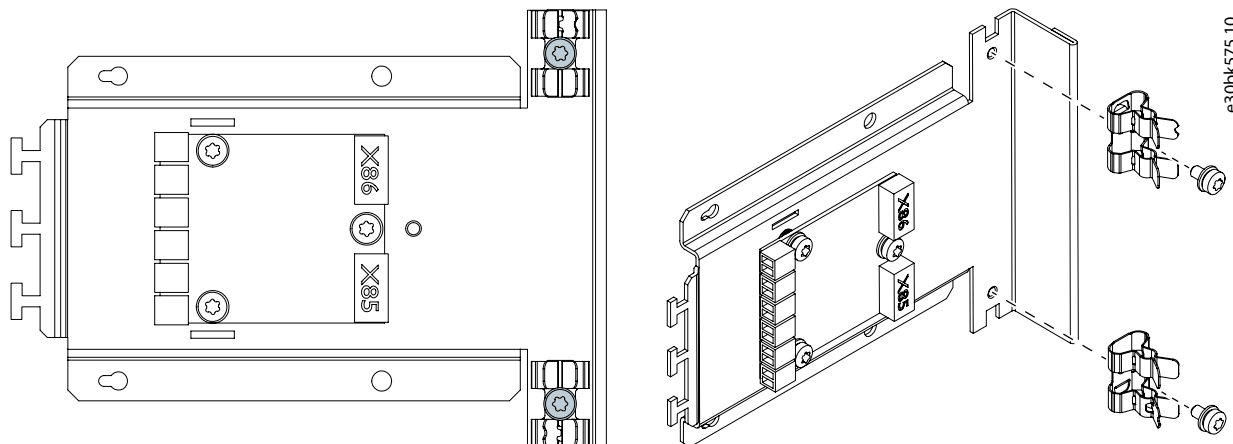

Illustration 7: Removing the Cable Clamps

3. Remove the AuxBus temperature measurement board from the assembly plate by removing the 3 size M4x8 screws. Save the screws.

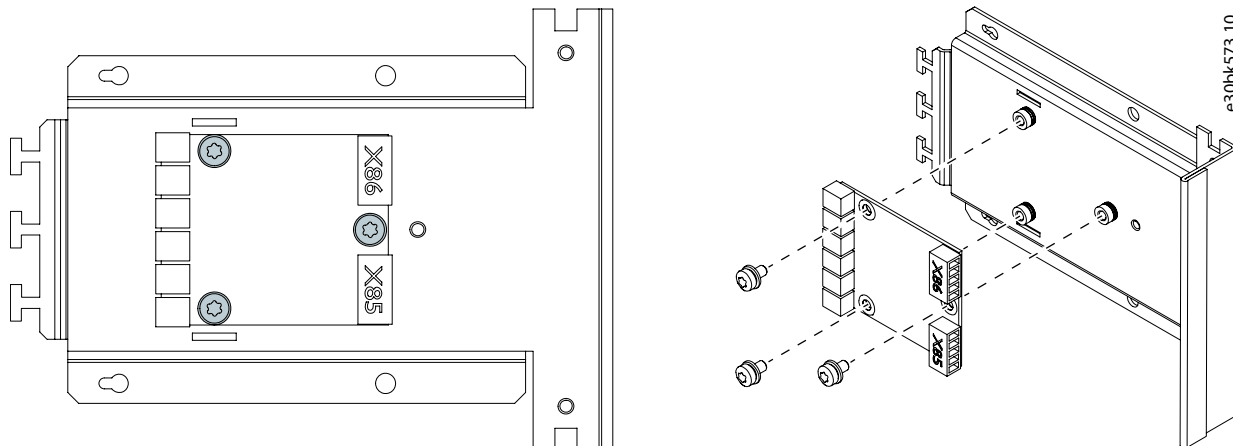

Illustration 8: Removing the AuxBus Temperature Measurement Board on the Assembly Plate

4. Attach the AuxBus temperature measurement board to the filter with 3 of the M4x8 screws.

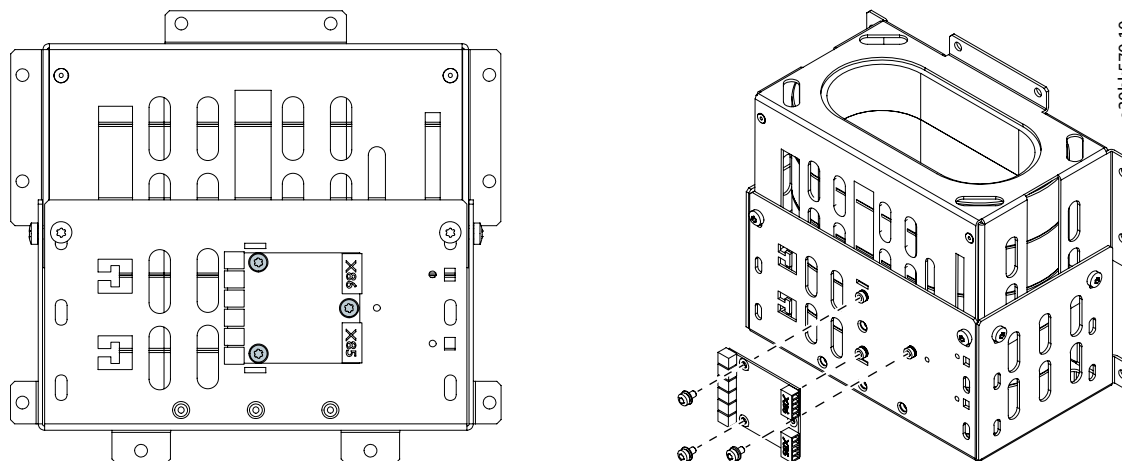

Illustration 9: Mounting the AuxBus Temperature Measurement Board to the Filter

5. Mount the 2 cable clamps to the filter frame with 2 of the M4x8 screws.

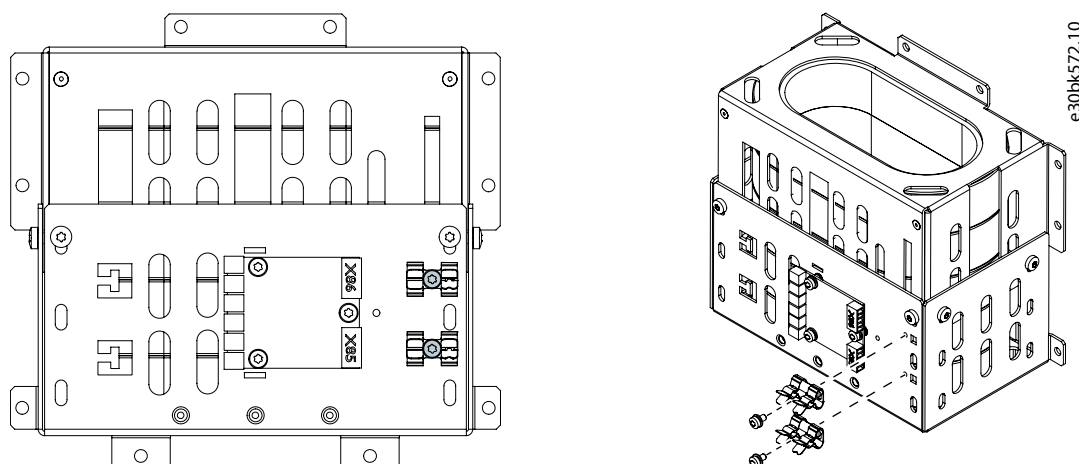

Illustration 10: Mounting the Cable Clamps

- Mount the touch cover on top of the board with 1 of the M4x8 screws.

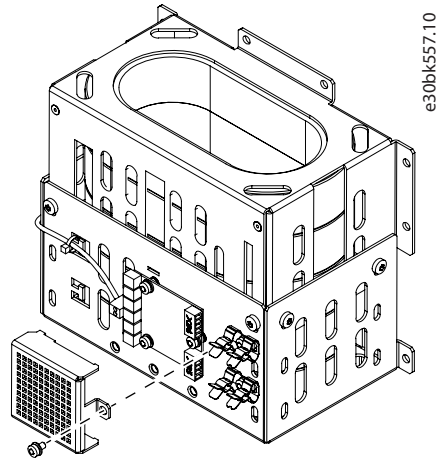
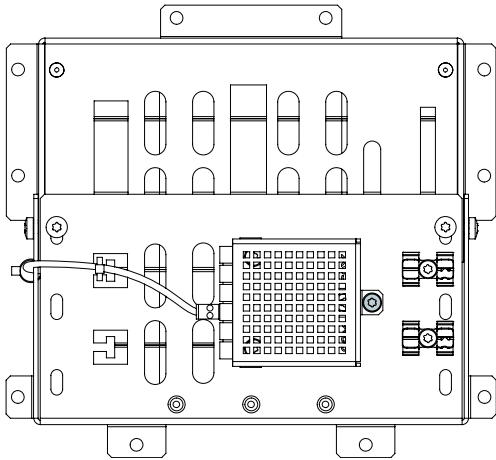

Illustration 11: Mounting the Touch Cover

- Connect the temperature measurement wire from the filter to terminal X204 on the AuxBus temperature measurement board.

The length of the wire is 1.5 m (4.9 ft). It is recommended to cut the wire shorter.

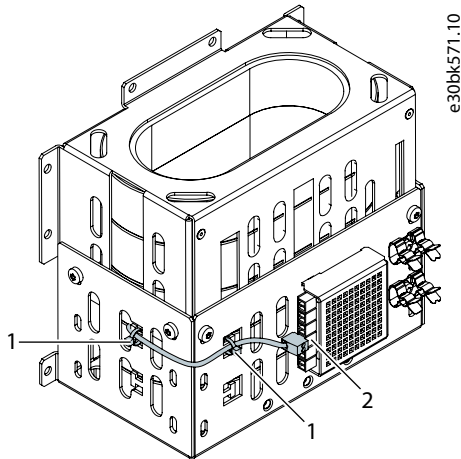

Illustration 12: Connecting and Routing of the Temperature Measurement Wire

1	Cable ties
2	Terminal X204

2.5 Cooling Requirements

The maximum ambient operating temperature of the Common-mode Filter is 40 °C (104 °F), with derating up to 55 °C (131 °F). The product requires forced air cooling. Make sure that the cooling airflow through the filter cores is sufficient. The minimum airflow is 3 m/s (10 ft/s).

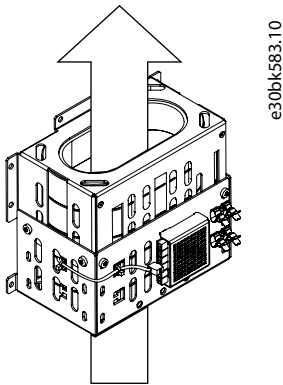

Illustration 13: Airflow Through the Filter Cores

2.6 Dimensions of the Common-mode Filter

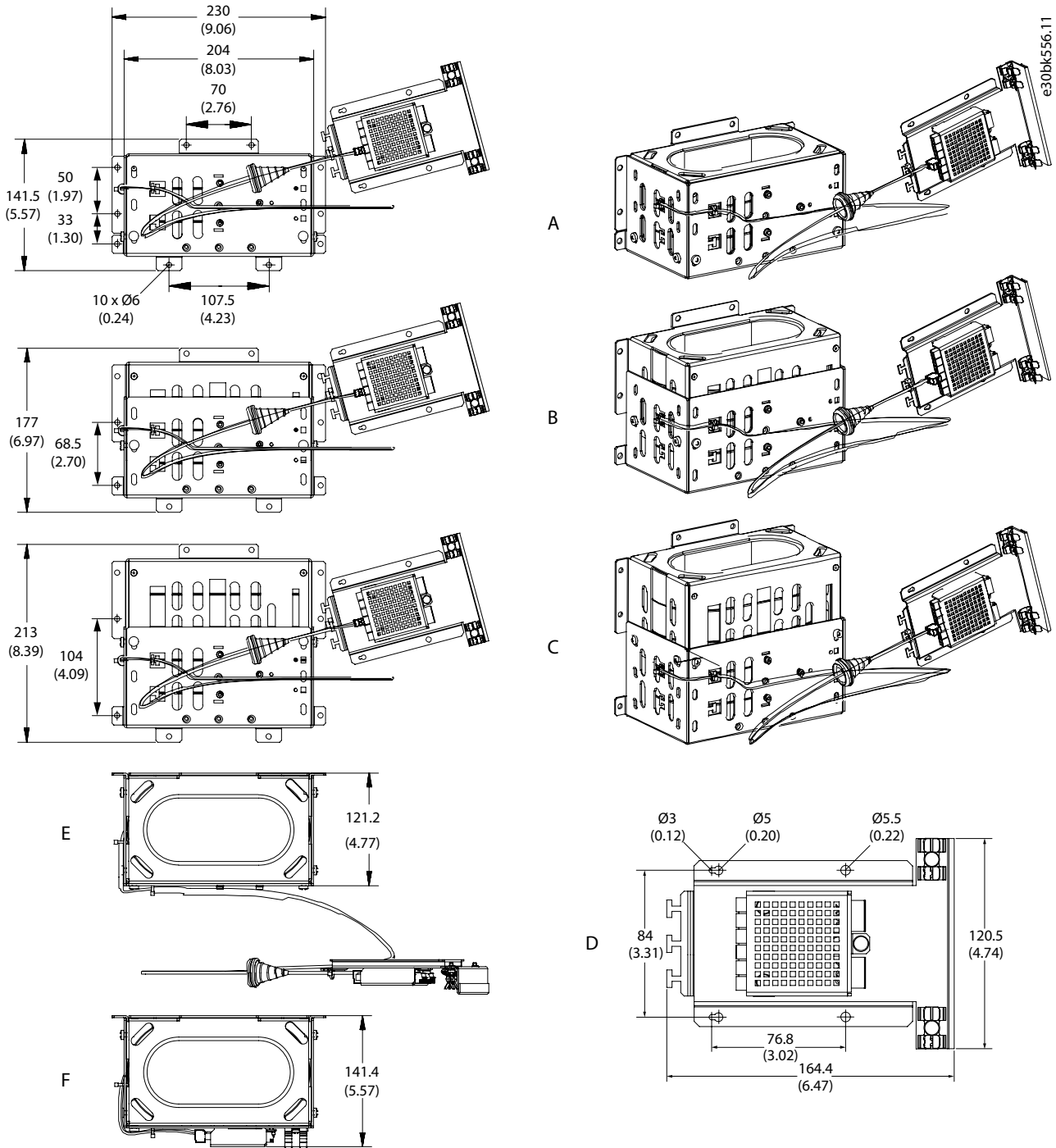

Illustration 14: Dimensions of the Common-mode Filter in mm (in)

A	Filter with 3 cores	D	AuxBus temperature measurement board assembly
B	Filter with 4 cores	E	Depth of the filter in IP54 installation
C	Filter with 5 cores	F	Depth of the filter in IP00 installation

3 Electrical Installation

3.1 Power Cabling

Install the Common-mode Filter at the inverter output. If the inverter has parallel power units, install a separate Common-mode Filter at the output of each power unit.

The Common-mode Filter can be installed as the only output filter, or it can be used with a dU/dt Filter or Sine-wave Filter. If another output filter is installed, install the Common-mode Filter between the other output filter and the motor.

See [3.4 Wiring Diagrams](#).

NOTICE

If grounding conductors are routed through the filter cores, the filter does not function properly.

- Only route the motor phase cables or busbars through the filter cores.
- Do not route any ground conductors through the filter cores.

Make sure that the cables or busbars do not touch the filter cores.

During operation, the filter cores can heat up to 130 °C (266 °F). If cables are used, they must be able to withstand this temperature. If the cables are not rated for such high temperatures, they must be routed so that they do not touch the filter cores.

3.2 Preparing the AuxBus Cable

1. Cut the cable to the required length.
2. To reveal the wires, strip the cable at both ends.
3. At 1 end of the cable, remove approximately 15 mm (0.59 in) of the insulation of the cable.
4. Strip the wires 7 mm (0.28 in).
5. Connect the wires to the terminals included in the delivery. Use the tightening torque 0.22–0.25 Nm (1.9–2.2 in-lb).

Table 1: Wiring of the AuxBus Terminals

Pin	Wire color	Signal
1	White	+24 V
2	Brown	GND
3	Green	CAN_H
4	Yellow	CAN_L
5	Grey	+24 V

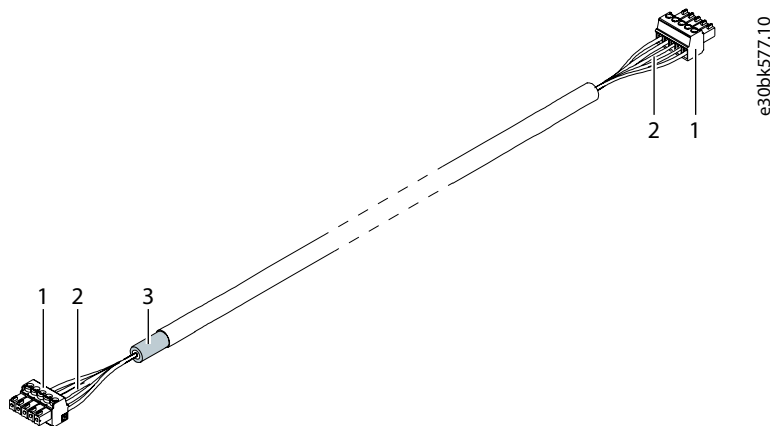

Illustration 15: The Ready AuxBus Cable

1	Terminals	3	Shield removed
2	Wires		

3.3 AuxBus Connections

NOTICE

For the drive to be able to protect the filters, AuxBus must be connected.

For more information about AuxBus, see the iC7 Series System Module operating guides.

1. Connect the AuxBus cable between the filter and the power unit. If there are several power units and filters, connect each filter to the power units individually.
 - a. Connect the end of the AuxBus cable where the insulation was removed to terminal X25 on the power unit.
 - b. Connect the other end of the AuxBus cable to terminal X86 on the AuxBus temperature measurement board.

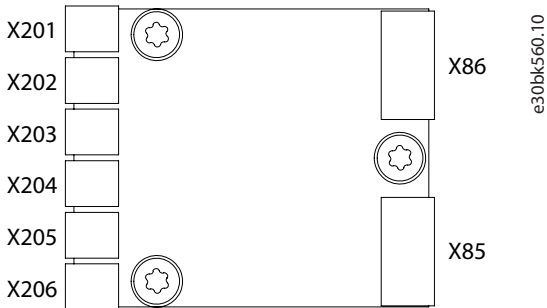

Illustration 16: Terminals on the AuxBus Temperature Measurement Board

X20_	Temperature measurement input	X86	AuxBus out
X85	AuxBus in		

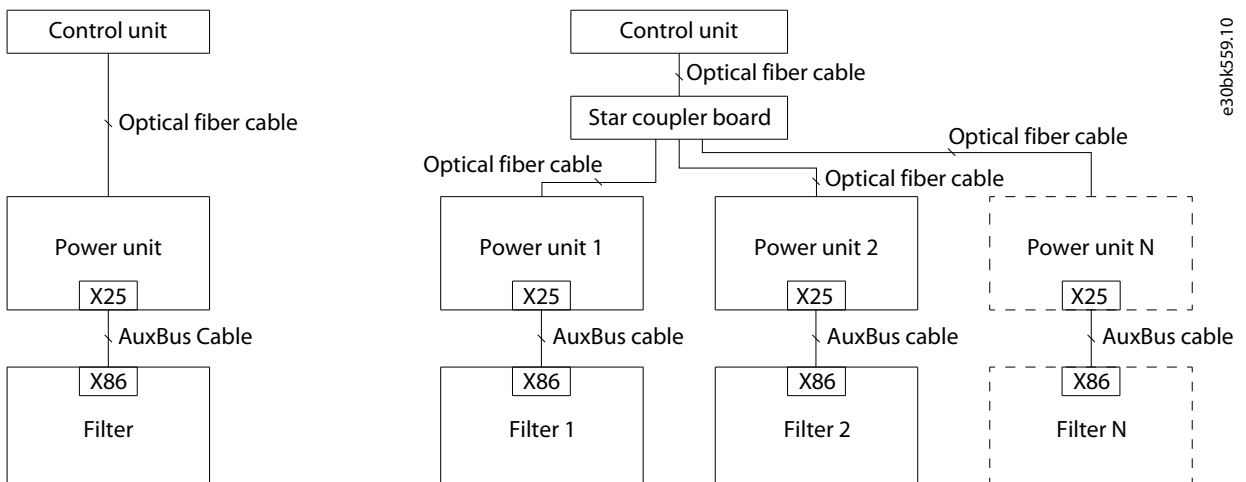

Illustration 17: AuxBus Topology

2. Route the cable so that there is no risk of getting in touch with bare busbars or terminals.
3. Ground each AuxBus cable at 1 end, at the X25 terminal. To make the grounding connection, attach the shield of the cable to the frame with a cable clamp.

The lower part of the cable clamp fixes the cable to the plate and provides strain relief. The upper part provides ~360° grounding for the cable shield.

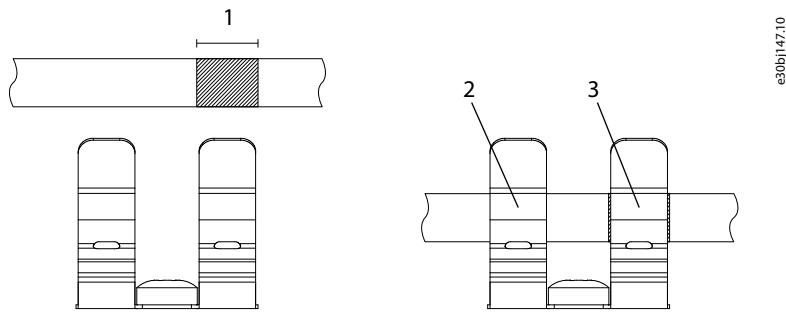

Illustration 18: Using the Cable Clamps

1	Stripping length, 15 mm (0.59 in)	3	Grounding
2	Strain relief		

- At the terminal X86 end of the cable, place the cable in a cable clamp for strain relief.

3.4 Wiring Diagrams

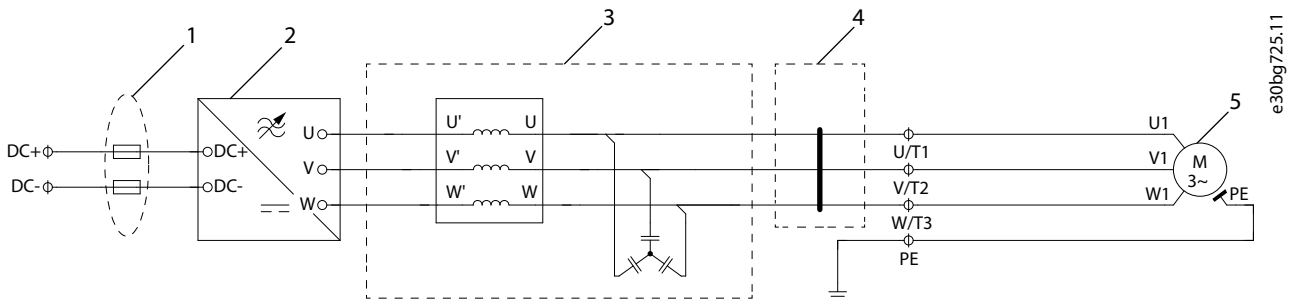
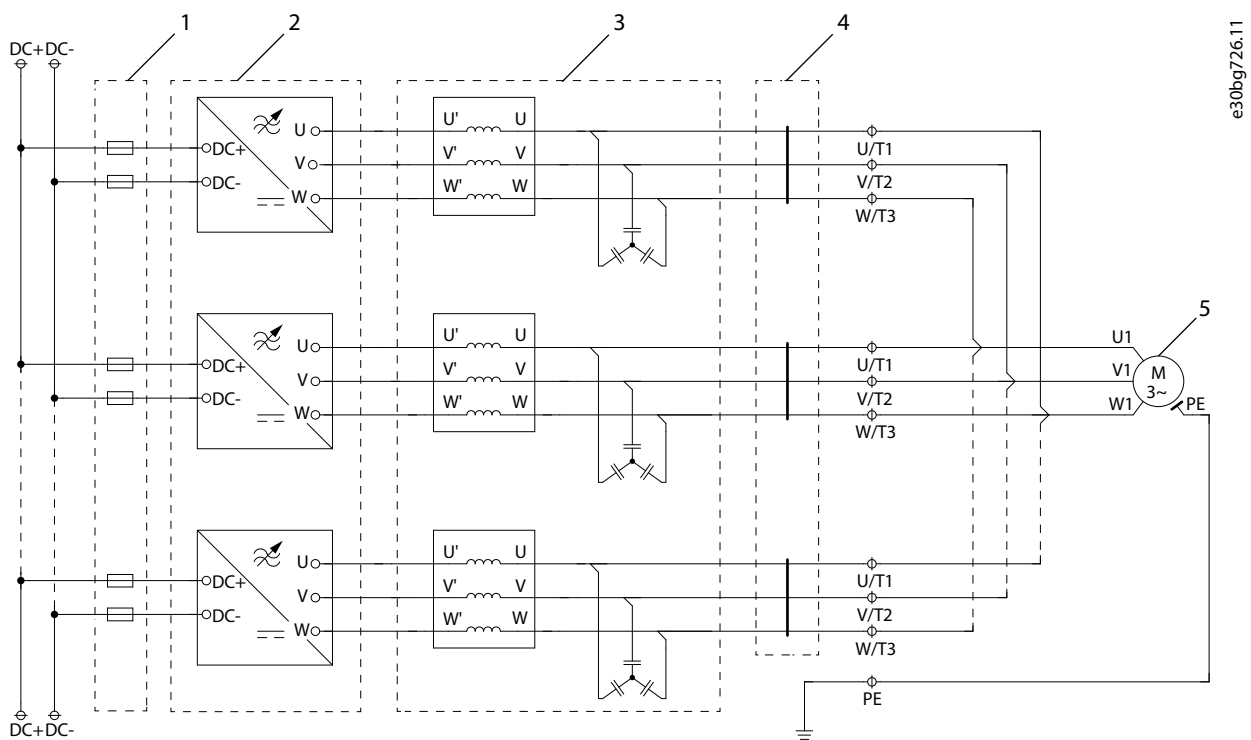

Illustration 19: Wiring Diagram for Inverter and Common-mode Filter

1	DC fuses	4	Common-mode Filter
2	Inverter module	5	Motor
3	dU/dt Filter or Sine-wave Filter (optional)		



e30bg726.11

Illustration 20: Wiring Diagram for Inverter with Parallel Power Units and Common-mode Filters

1	DC fuses	4	Common-mode Filters
2	Inverter modules	5	Motor
3	dU/dt Filters or Sine-wave Filters (optional)		

Vacon Ltd, Member of the
Danfoss Group
 Runsorintie 7
 FIN-65380 Vaasa
www.danfoss.com

Danfoss can accept no responsibility for possible errors in catalogs, brochures and other printed material. Danfoss reserves the right to alter its products without notice. This also applies to products already on order provided that such alterations can be made without subsequent changes being necessary in specifications already agreed. All trademarks in this material are property of the respective companies. Danfoss and the Danfoss logotype are trademarks of Danfoss A/S. All rights reserved.

