

WIRE COLOR SCHEME
 BLACK - LINE VOLTAGE
 RED - AC CONTROL
 WHITE - AC GROUND
 BLUE - DC CONTROL
 WHT/BLU - DC CONTROL COMMON
 GREEN - CHASSIS GROUND

* ALL CONTROL WIRES ARE BLUE EXCEPT WHERE NOTED. TO ELECTROMECHANICAL RELAY BOARD

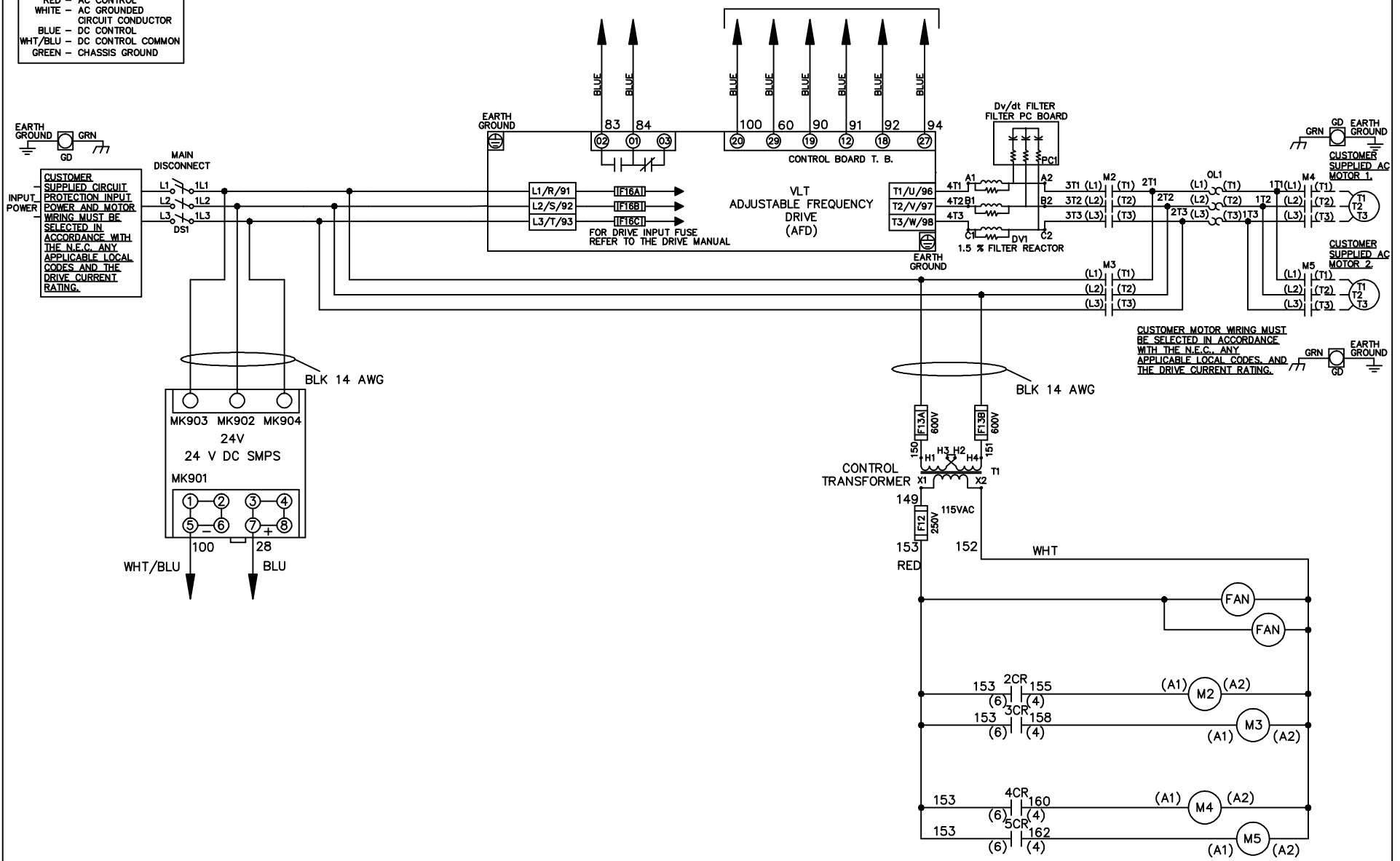

CUSTOMER MOTOR WIRING MUST BE SELECTED IN ACCORDANCE WITH THE N.E.C. ANY APPLICABLE LOCAL CODES AND THE DRIVE CURRENT RATING.

-NOTICE-

THIS DRAWING IS PROPRIETARY AND SHALL NOT BE COPIED OR ITS CONTENTS DISCLOSED TO OUTSIDE PARTIES WITHOUT THE WRITTEN CONSENT OF THE TRANE COMPANY

DRN JNW
2/8/07

NAME 460 VOLT, 2C, MAIN DISC
 , DRIVE FUSE, EMB2, FRAME D1-D2
 , DVDT, CMS

THE TRANE COMPANY
 A DIVISION OF
 AMERICAN STANDARD INC.

A	SP08061	10/08
REV	ECN	DATE

APR

MODEL

PAGE 1 OF 2

SIZE A

DWG NO.

174U7373

REV	A	ECON	DATE	DRN JNW	MODEL	SIZE	DWG NO.
	SP08066	10/08		2/14/07	NAME 460 VOLT, 2C MAIN DISC , DRIVE FUSE, EMB2, FRAME D1-D2 , DVDT, CMS	A	174U7373
THIS DRAWING IS PROPRIETARY AND SHALL NOT BE COPIED OR ITS CONTENTS DISCLOSED TO OUTSIDE PARTIES WITHOUT THE WRITTEN CONSENT OF THE TRANE COMPANY				-NOTICE-			
				THE TRANE COMPANY A DIVISION OF AMERICAN STANDARD INC.			

CONTACT SEQUENCE CHART FOR S1
X INDICATES CONTACT CLOSED

CONTACT	POSITION
13-14	DRIVE
13-14	OFF
23-24	BYPASS
	DRIVE
	OFF
	BYPASS



CONTACT SEQUENCE CHART FOR S2
X INDICATES CONTACT CLOSED

CONTACT	POSITION
11-12	MOTOR 1
11-12	AUTO
13-14	MOTOR 2
13-14	AUTO
21-22	MOTOR 1
21-22	AUTO
23-24	MOTOR 2
23-24	AUTO

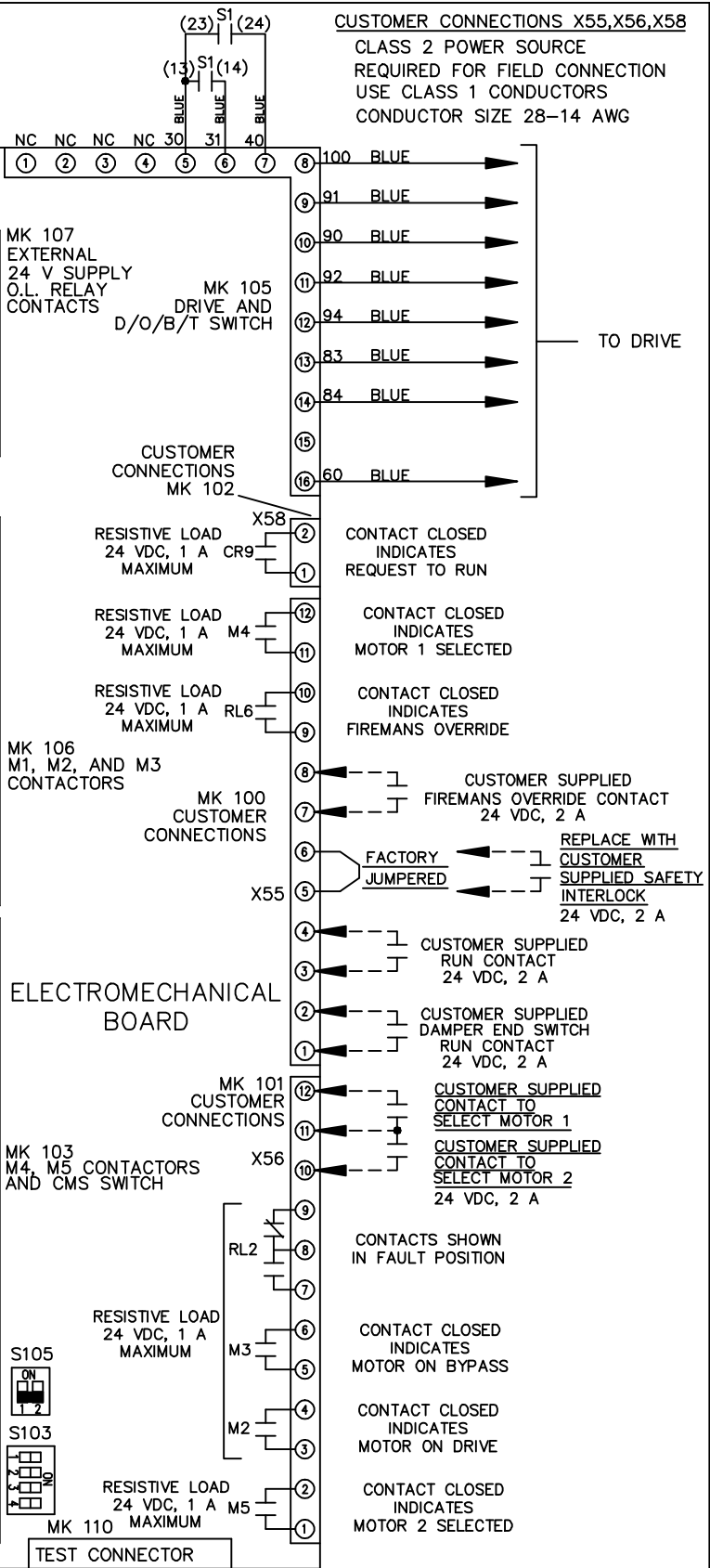
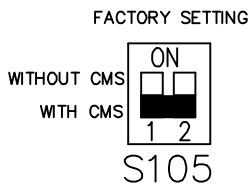

ELECTROMECHANICAL BOARD

