

4

3

2

1

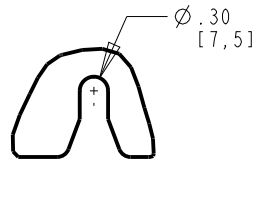
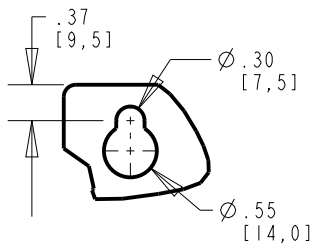
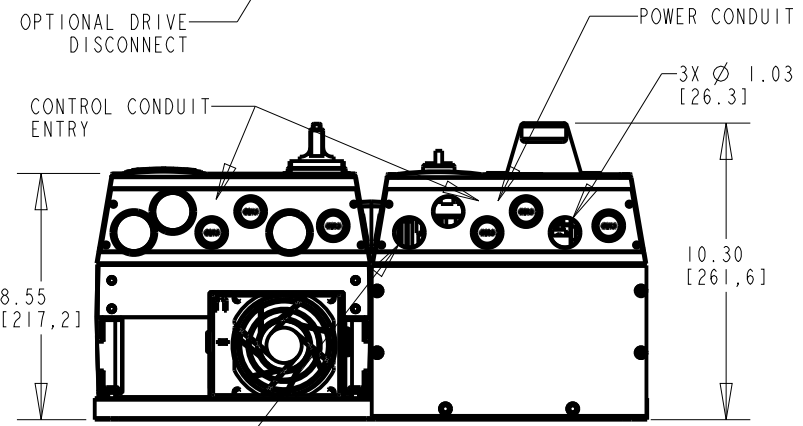
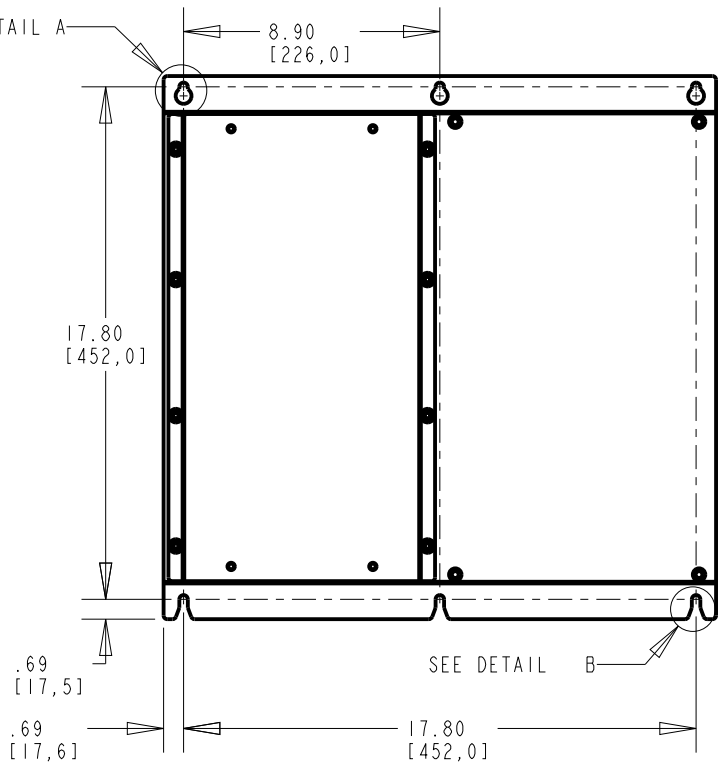
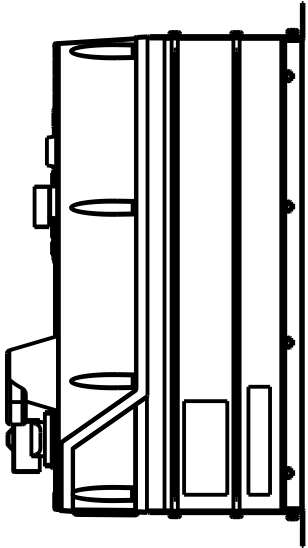
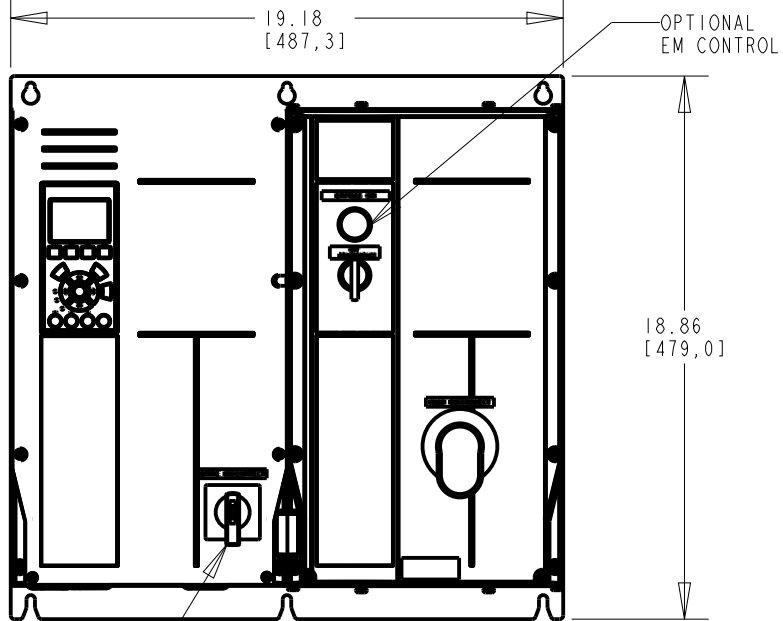

- 1) 3X PLACE CONDUITS IN PRE-EXISTING CONDUIT HOLES. IF NOT USED, PLUG WITH NEMA TYPE 12 HOLE PLUGS.
- 2) FOR NEMA TYPE 12 UNITS USE NEMA TYPE 12 CONDUITS AND HUBS

CLEARANCE REQUIREMENT FOR AIR FLOW COOLING:
 THE UNIT MUST BE INSTALLED VERTICALLY WITH THE MINIMUM CLEARANCE OF 3.94" [100.0mm] ON THE TOP AND BOTTOM. ALL UL NEMA TYPE 1/IP21 AND NEMA TYPE 12/IP54 UNITS MAY BE MOUNTED SIDE BY SIDE WITH NO MINIMUM SIDE CLEARANCE.

UNIT APPROXIMATE WEIGHT: 55 Lbs [25 Kg]

| FRAME SIZE A5 | | |
|---------------|--------|----------|
| VOLTAGE | HP | KW |
| 208/230 | 0.5-5 | 0.75-3.7 |
| 460/600 | 0.5-10 | 0.75-7.5 |

- NOTICE -

THIS DOCUMENT CONTAINS PROPRIETARY INFORMATION OF DANFOSS DRIVES. IT IS LOANED BY DANFOSS DRIVES SUBJECT TO THE CONDITIONS THAT IT AND THE INFORMATION EMBODIED THEREIN SHALL BE USED ONLY FOR RECORD AND REFERENCE PURPOSES, SHALL NOT BE USED OR CAUSED TO BE USED IN ANY WAY PREJUDICIAL TO THE INTERESTS OF DANFOSS DRIVES, SHALL NOT BE REPRODUCED OR COPIED IN WHOLE OR IN PART OR DISCLOSED TO ANYONE WITHOUT THE DIRECT WRITTEN PERMISSION OF DANFOSS DRIVES, AND SHALL BE RETURNED UPON REQUEST.

PRO-E ENTRY BY/DATE:
MG 12/20/06

DESIGNED BY/DATE:
MG 12/20/06

APPROVAL:

CHECKED BY/DATE:

MFG. APPROVAL BY/DATE:

ENG. APPROVAL BY/DATE:

Danfoss

DANFOSS DRIVES
4401 N. BELL SCHOOL RD., LOVES PARK, ILLINOIS 61111 USA
(615) 639-9600 FAX (615) 639-9000

TITLE:
DWG, REF, SUBMITTAL, A5-TIER 2

LATEST E.C.N. NO.: SP10032

E.C.N. PRO-E ENTRY BY/DATE: DK 3/30/10

PLOT SCALE: NONE

PRO-E FILE: 176U5290

SHEET: 1 OF: 1

DRAWING NO.: 176U5290

REV.: A

4

3

2

1