

**WARNING!**  
 THE FOLLOWING TABLE LISTS THE PARAMETERS THAT ARE SET DIFFERENT FROM THE DRIVE DEFAULT SETTINGS. ADDITIONAL PARAMETER SETTINGS MAY BE REQUIRED FOR YOUR APPLICATION.

DRIVE PARAMETER SETTINGS

| PARAMETER # | NAME              | SETTING | VALUE                |
|-------------|-------------------|---------|----------------------|
| 0-02        | MOTOR SPEED UNIT  | 1       | HZ                   |
| 0-03        | REGIONAL SETTINGS | 1       | NORTH AMERICA        |
| 1-03        | TORQUE CHAR.      | 3       | AUTO ENERGY OPTIM VT |
| 5-02        | TERMINAL 29 TYPE  | 1       | OUTPUT               |
| 5-31        | TERMINAL 29       | 5       | RUNNING              |
| 14-20       | RESET MODE        | 13      | INFINITE AUTO REST   |

- NOTES:
- \* INDICATES COMPONENTS NOT SUPPLIED BY MANUFACTURER.
  - REFER TO THE INSTALLATION AND OPERATION MANUAL FOR DRIVE FUNCTIONS AND PARAMETER SETTINGS.
  - BRANCHCIRCUIT PROTECTION, INPUT POWER AND MOTOR WIRING MUST BE SELECTED IN ACCORDANCE WITH THE N.E.C., ANY APPLICATION LOCAL CODES AND THE LOAD CURRENT RATING.
  - REPLACE JUMPER 'J1' WITH NORMALLY CLOSED SAFETY INTERLOCK CONTACT AS NECESSARY. CONTACT MUST BE RATED 1/4 HP @ 120VAC MINIMUM.
  - PANEL MAY REQUIRE DERATING, CONSULT DRIVE MANUAL OR FACTORY FOR FOLLOWING CONDITIONS:
    - HIGHER SWITCHING FREQUENCY THAN DRIVE DEFAULT
    - HIGHER THAN PANEL LISTED AMBIENT TEMPERATURES
    - ELEVATION ABOVE 3300 FEET (1000 METERS)
    - LONG MOTOR LEAD LENGTHS

|     |         |       |   |     |  |       |       |      |  |         |          |
|-----|---------|-------|---|-----|--|-------|-------|------|--|---------|----------|
| B   |         |       | -NOTICE-<br>THIS DRAWING IS PROPRIETARY AND SHALL NOT BE COPIED OR ITS CONTENTS DISCLOSED TO OUTSIDE PARTIES WITHOUT THE WRITTEN CONSENT OF THE TRANE COMPANY | DRN | NAME<br>NEMA 3R,208V,3C<br>,MAIN DISC, DRIVE FUSE<br>,3MB1,IR,CONTACT MOTOR SELECT,1 FAN |       |       |      | THE TRANE COMPANY<br>A DIVISION OF<br>AMERICAN STANDARD INC. |         |          |
| A   | SP10119 | 11/10 |   | DTM | APR  | MODEL | TR200 | PAGE |  |         | 1 OF 2   |
| DR  | SP10076 | 09/10 |   |     | DTM  |       |       |      |  | DWG NO. | 185B2483 |
| REV | ECN     | DATE  |   |     |  |       |       |      |  |         |          |

**WIRE COLOR SCHEME**  
 BLACK - LINE VOLTAGE  
 RED - AC CONTROL  
 WHITE - AC CONTROL  
 WHITE - AC GROUNDED  
 CIRCUIT CONDUCTOR  
 BLUE - DC CONTROL  
 GREEN - DC CONTROL  
 CHASSIS GROUND

**TERMINAL IDENTIFICATION**  
 [X] - DRIVE TERMINAL  
 (X) - CUSTOMER TERMINAL

**CUSTOMER DRY CONTACT RATINGS**

| RELAY                 | CONTACT RATING                  |
|-----------------------|---------------------------------|
| CR1, CR6              | 5A @ 120VAC<br>1/10 HP @ 120VAC |
| M1, M2, M3,<br>M4, M5 | 10A @ 120/240VAC                |

**CONTACT SEQUENCE CHART FOR S1**  
X INDICATES CONTACT CLOSED

| POSITION | DRIVE | OFF | BYPASS | TEST |
|----------|-------|-----|--------|------|
| 1-2      | X     |     |        | X    |
| 3-4      |       |     | X      | X    |
| 5-6      | X     |     |        |      |
| 7-8      |       |     |        | X    |

**CONTACT SEQUENCE CHART FOR S2**  
X INDICATES CONTACT CLOSED

| POSITION | MOTOR 1 | AUTO | MOTOR 2 |
|----------|---------|------|---------|
| 11-12    | X       | X    |         |
| 13-14    |         |      | X       |
| 21-22    |         | X    | X       |
| 23-24    | X       |      |         |

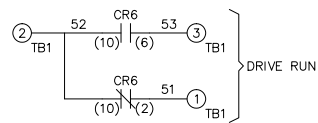
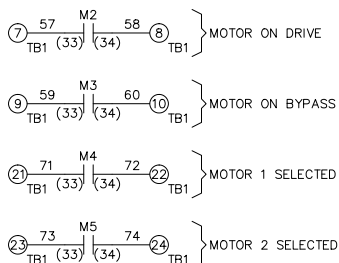
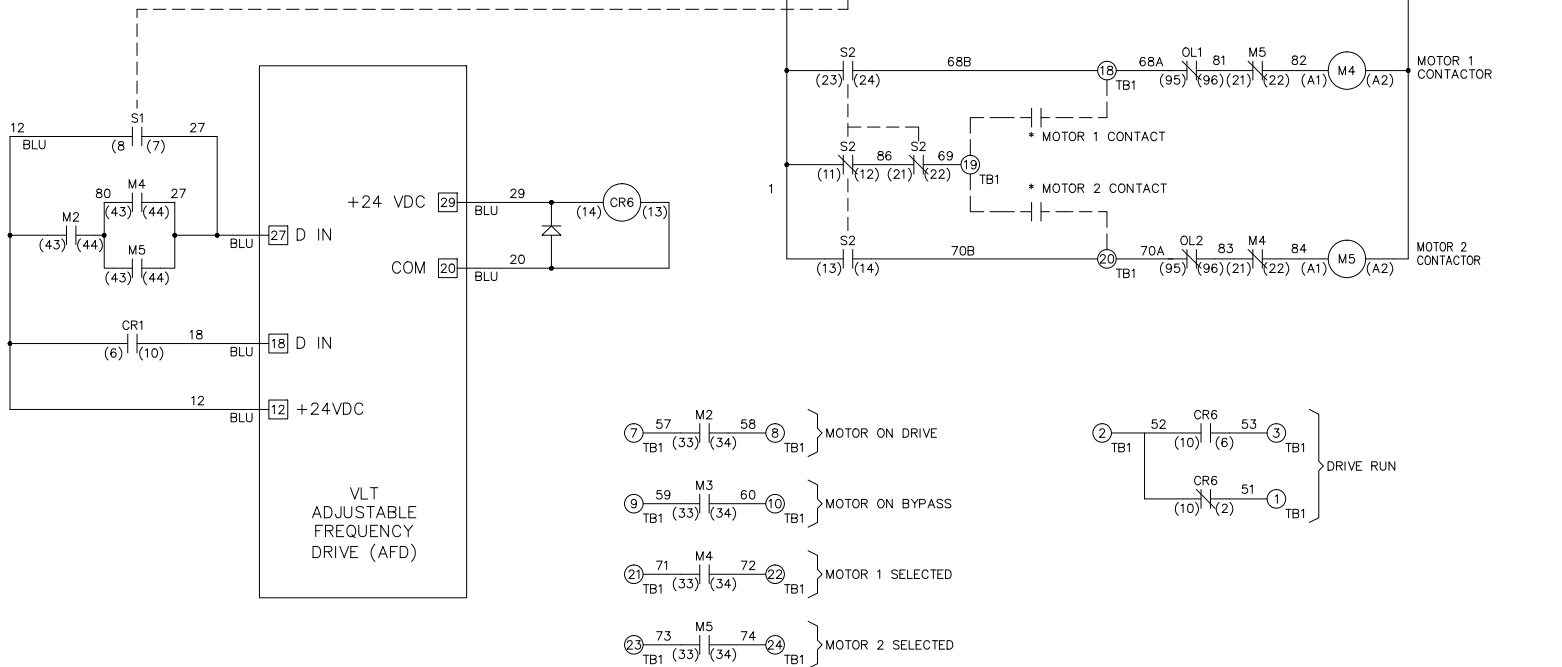

|     |         |       |
|-----|---------|-------|
| B   |         |       |
| A   | SP10119 | 11/10 |
| DR  | SP10076 | 09/10 |
| REV | ECN     | DATE  |

-NOTICE-  
 THIS DRAWING IS PROPRIETARY AND SHALL NOT  
 BE COPIED OR ITS CONTENTS DISCLOSED TO  
 OUTSIDE PARTIES WITHOUT THE WRITTEN  
 CONSENT OF THE TRANE COMPANY

DRN  
*DTM*  
 APR  
*DTM*

NAME  
 NEMA 3R, 208V, 3C  
 , MAIN DISC, DRIVE FUSE  
 , 3MB1, IR, CONTACT MOTOR SELECT, 1 FAN  
 MODEL TR200

**THE TRANE COMPANY**  
 A DIVISION OF  
 AMERICAN STANDARD INC.  
 PAGE 2 OF 2  
 SIZE A  
 DWG NO. 185B2483