

- NOTES:**
- * INDICATES COMPONENTS NOT SUPPLIED BY MANUFACTURER.
 - REFER TO THE INSTALLATION AND OPERATION MANUAL FOR DRIVE FUNCTIONS AND PARAMETER SETTINGS.
 - FEEDER CIRCUIT PROTECTION, INPUT POWER AND MOTOR WIRING MUST BE SELECTED IN ACCORDANCE WITH THE N.E.C., ANY APPLICATION LOCAL CODES AND THE LOAD CURRENT RATING.
 - REPLACE JUMPER 'J1' WITH NORMALLY CLOSED SAFETY INTERLOCK CONTACT AS NECESSARY. CONTACT MUST BE RATED 1/4 HP @ 120VAC MINIMUM.
 - PANEL MAY REQUIRE DERATING, CONSULT DRIVE MANUAL OR FACTORY FOR FOLLOWING CONDITIONS:
 - HIGHER SWITCHING FREQUENCY THAN DRIVE DEFAULT
 - HIGHER THAN PANEL LISTED AMBIENT TEMPERATURES
 - ELEVATION ABOVE 3300 FEET (1000 METERS)
 - LONG MOTOR LEAD LENGTHS

| | | | | | | | | | | | |
|-----|---------|-------|---|-----|-------------------------------------|-------|------|--------|---|---|---------|
| B | | | -NOTICE- THIS DRAWING IS PROPRIETARY AND SHALL NOT BE COPIED OR ITS CONTENTS DISCLOSED TO OUTSIDE PARTIES WITHOUT THE WRITTEN CONSENT OF THE TRANE COMPANY | DRN | NAME NEMA 3R,600V,3C | | | | THE TRANE COMPANY A DIVISION OF AMERICAN STANDARD INC. | | |
| A | SP10119 | 11/10 | | DTM | , MAIN DISC, MAIN & DRIVE FUSE | | | | | | |
| DR | SP10076 | 09/10 | | APR | ,3MB2,IR,CONTACT MOTOR SELECT,1 FAN | | | | | | |
| REV | ECN | DATE | | DTM | MODEL | TR200 | PAGE | 1 OF 2 | SIZE | A | DWG NO. |

| WIRE COLOR SCHEME | |
|-------------------|------------------|
| BLACK | - LINE VOLTAGE |
| RED | - AC CONTROL |
| WHITE | - AC GROUNDED |
| BLUE | - DC CONTROL |
| GREEN | - CHASSIS GROUND |

| TERMINAL IDENTIFICATION | |
|-------------------------|---------------------|
| X | - DRIVE TERMINAL |
| ⊗ | - CUSTOMER TERMINAL |

| CUSTOMER DRY CONTACT RATINGS | |
|------------------------------|---------------------------------|
| RELAY | CONTACT RATING |
| CR1, CR2, CR6, CR8, CR9 | 5A @ 120VAC 1/10 HP @ 120VAC |
| M1, M2, M3, M4, M5 | 10A @ 120/240VAC |
| UV | 8A @ 120VAC 1/3 HP @ 120VAC |
| TD1 | 4A @ 250VAC |
| DRIVE RELAY 1 & 2 | 2A @ 240VAC |

| CONTACT SEQUENCE CHART FOR S1 X INDICATES CONTACT CLOSED | | | | |
|---|-------|-----|--------|------|
| POSITION | DRIVE | OFF | BYPASS | TEST |
| 1-2 | X | | | X |
| 3-4 | | | X | X |
| 5-6 | X | | | |
| 7-8 | | | | X |

| CONTACT SEQUENCE CHART FOR S2 X INDICATES CONTACT CLOSED | | | |
|---|---------|------|---------|
| POSITION | MOTOR 1 | AUTO | MOTOR 2 |
| 11-12 | X | X | |
| 13-14 | | | X |
| 21-22 | | X | X |
| 23-24 | X | | |

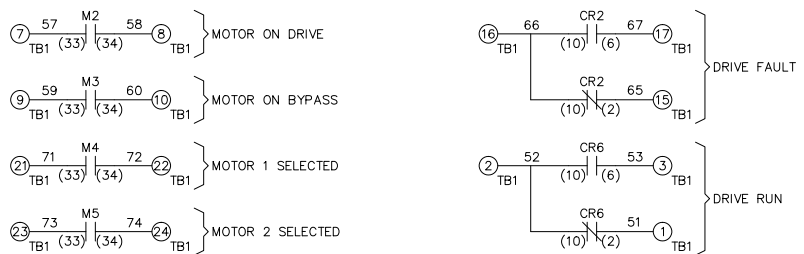
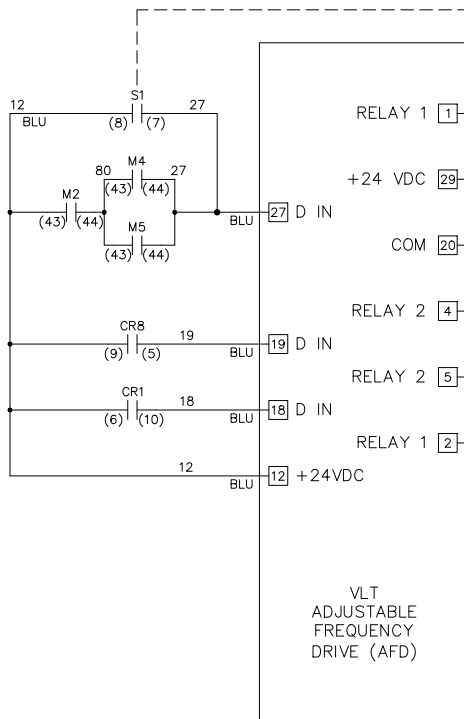
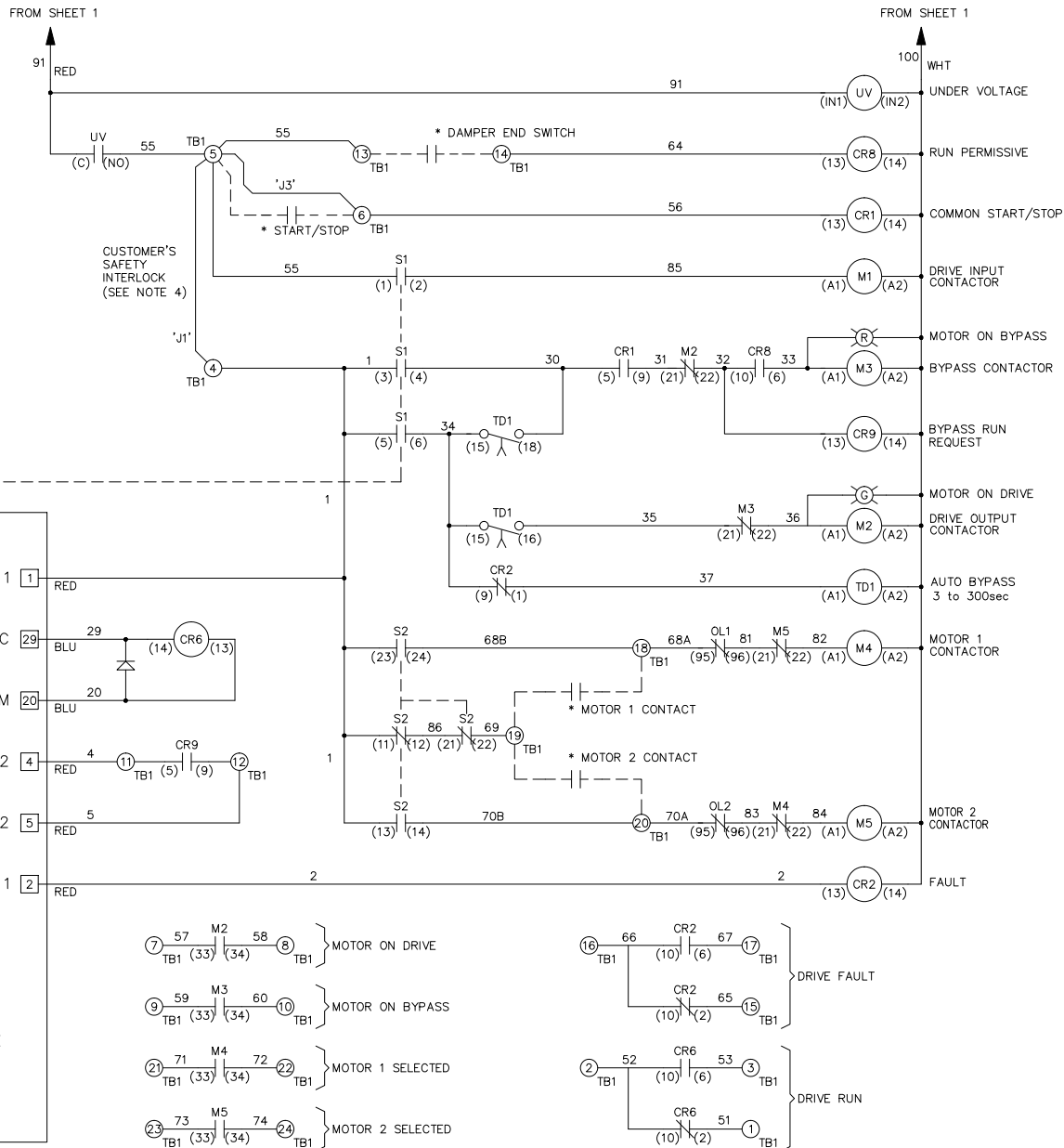

| | | |
|-----|---------|-------|
| B | | |
| A | SP10119 | 11/10 |
| DR | SP10076 | 09/10 |
| REV | ECN | DATE |

-NOTICE-
THIS DRAWING IS PROPRIETARY AND SHALL NOT BE COPIED OR ITS CONTENTS DISCLOSED TO OUTSIDE PARTIES WITHOUT THE WRITTEN CONSENT OF THE TRANE COMPANY

DRN *DTM*
APR *DTM*

NAME NEMA 3R,600V,3C
, MAIN DISC, MAIN & DRIVE FUSE
,3MB2,1R,CONTACT MOTOR SELECT,1 FAN

THE TRANE COMPANY
A DIVISION OF
AMERICAN STANDARD INC.

MODEL TR200 PAGE 2 OF 2 SIZE A DWG NO. 185B3209