

WIRE COLOR SCHEME
 BLACK - LINE VOLTAGE
 RED - AC CONTROL
 WHITE - AC GROUNDED
 CIRCUIT CONDUCTOR
 BLUE - DC CONTROL
 GREEN - CHASSIS GROUND

TERMINAL IDENTIFICATION
 [X] - DRIVE TERMINAL
 (X) - CUSTOMER TERMINAL

*CUSTOMER SUPPLIED FEEDER CIRCUIT PROTECTION (SEE NOTE 3)

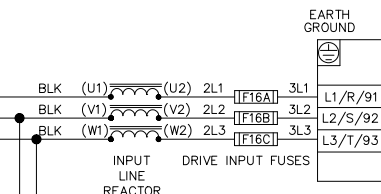
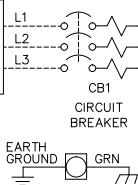

VLT ADJUSTABLE FREQUENCY DRIVE (AFD)

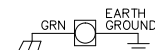

* AC MOTOR 1 (SEE NOTES 6)

* AC MOTOR 2 (SEE NOTES 6)

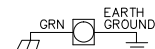

CUSTOMER DRY CONTACT RATINGS

| RELAY | CONTACT RATING |
|-------|---------------------------------|
| CR6 | 5A @ 120VAC 1/10 HP @ 120VAC |

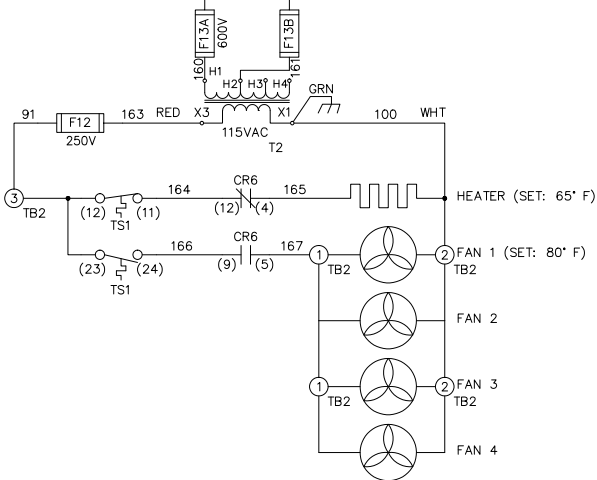

WARNING!
 THE FOLLOWING TABLE LISTS THE PARAMETERS THAT ARE SET DIFFERENT FROM THE DRIVE DEFAULT SETTINGS. ADDITIONAL PARAMETER SETTINGS MAY BE REQUIRED FOR YOUR APPLICATION.

DRIVE PARAMETER SETTINGS

| PARAMETER # | NAME | SETTING | VALUE |
|-------------|-------------------|---------|--------------------|
| 0-02 | MOTOR SPEED UNIT | 1 | HZ |
| 0-03 | REGIONAL SETTINGS | 1 | NORTH AMERICA |
| 1-03 | TORQUE CHAR. | 1 | VARIABLE TORQUE |
| 5-02 | TERMINAL 29 TYPE | 1 | OUTPUT |
| 5-31 | TERMINAL 29 | 5 | RUNNING |
| 14-20 | RESET MODE | 13 | INFINITE AUTO REST |

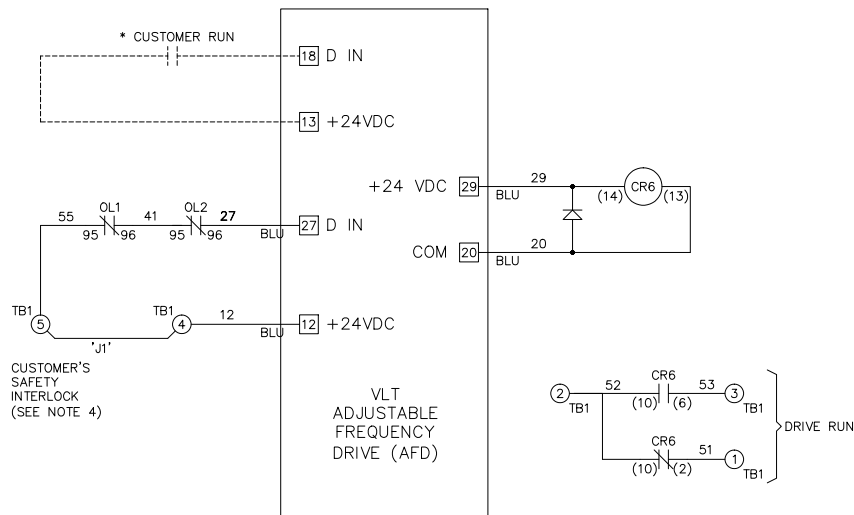

NOTES:

- * INDICATES COMPONENTS NOT SUPPLIED BY MANUFACTURER.
- REFER TO THE INSTALLATION AND OPERATION MANUAL FOR DRIVE FUNCTIONS AND PARAMETER SETTINGS.
- FEEDER CIRCUIT PROTECTION, INPUT POWER AND MOTOR WIRING MUST BE SELECTED IN ACCORDANCE WITH THE N.E.C., ANY APPLICATION LOCAL CODES AND THE LOAD CURRENT RATING.
- REPLACE JUMPER 'J1' WITH NORMALLY CLOSED SAFETY INTERLOCK CONTACT AS NECESSARY.
- PANEL MAY REQUIRE DERATING, CONSULT DRIVE MANUAL OR FACTORY FOR FOLLOWING CONDITIONS:
 - HIGHER SWITCHING FREQUENCY THAN DRIVE DEFAULT
 - HIGHER THAN PANEL LISTED AMBIENT TEMPERATURES
 - ELEVATION ABOVE 3300 FEET (1000 METERS)
 - LONG MOTOR LEAD LENGTHS
- WHEN MOTOR OVERLOADS SIZES ARE DIFFERENT, MOTOR 1 WILL BE THE LARGER OF THE TWO MOTORS

| | | | | | | | | | |
|-----|---------|-------|---|-----|---|-------|-------------|--|---|
| B | | | -NOTICE- THIS DRAWING IS PROPRIETARY AND SHALL NOT BE COPIED OR ITS CONTENTS DISCLOSED TO OUTSIDE PARTIES WITHOUT THE WRITTEN CONSENT OF THE TRANE COMPANY | DRN | NAME NEMA 3R,208V,NB ,MAIN CB ,DRIVE FUSE ,IR,DUAL MOTOR,4 FAN | | | THE TRANE COMPANY A DIVISION OF AMERICAN STANDARD INC. | |
| A | SP10119 | 11/10 | | DTM | | | | | |
| DR | SP10076 | 09/10 | | APR | MODEL | TR200 | PAGE 1 OF 1 | SIZE | A |
| REV | ECN | DATE | | DTM | | | DWG NO. | 185B4108 | |