

# 300/500 A Current Sensor Kit for D2h/D4h/D7h/D8h Drives

## VLT® FC Series FC 102, FC 103, FC 202, FC 302

### 1 Overview

#### 1.1 Description

The 300 A and 500 A current sensor kits are designed for D2h/D4h/D7h/D8h drives shown in [Table 1](#) and [Table 2](#). The power rating of the drive is listed on the nameplate as characters 7–10 of the type code (T/C).

**Table 1: Applicable Power Ranges for 300 A Current Sensor Kit**

Product group and series	Voltage rating	Power rating [kW (hp)]
VLT® HVAC Drive FC 102	(T4) 380–480 V	200 (300)
VLT® Refrigeration Drive FC 103 VLT® AQUA Drive FC 202	(T7) 525–690 V	200–315 (250–350)
VLT® AutomationDrive FC 302	(T5) 380–500 V	160 (250)
	(T7) 525–690 V	160–250 (200–300)

**Table 2: Applicable Power Ranges for 500 A Current Sensor Kit**

Product group and series	Voltage rating	Power rating [kW (hp)]
VLT® HVAC Drive FC 102	(T4) 380–480 V	250–315 (350–450)
VLT® Refrigeration Drive FC 103 VLT® AQUA Drive FC 202	(T7) 525–690 V	400 (400)
VLT® AutomationDrive FC 302	(T5) 380–500 V	200–250 (300–350)
	(T7) 525–690 V	315 (350)

#### 1.2 Kit Numbers

**Table 3: Numbers for 300 A and 500 A Current Sensor Kits**

Number	Description
176F3752	300 A Current Sensor Conversion Kit D2h/D4h/D7h/D8h
176F3737	500 A Current Sensor Conversion Kit D2h/D4h/D7h/D8h

#### 1.3 Items Supplied

[Table 4](#) provides a list of items included in the 300/500 A current sensor kits. Refer also to [3.1 Kit Overview](#).

**Table 4: Items Supplied in 300 A and 500 A Current Sensor Kits**

Item	Quantity
M5x16 countersunk screw	3
Terminal plate	3
R/S/T terminal label	1
M10x30 machine screw	6

Item	Quantity
M10 nut	6
Mains terminal block	1
M5x12 screw	12
U/V/W terminal label	1
Cable clip (blind hole)	4
Motor terminal block	1
Cable clip (standard)	4-6
M10 flange nut	4
Cable clamp bracket	2
Power terminal mounting plate (IP21/IP54)	1
Power terminal mounting plate (IP20/Chassis)	1
Mixing fan	1
Mixing fan housing	1
Insulator sheet (EMC shield)	1
Plastic mounting button	3
Busbar insulator sleeve (for U motor busbar)	1
Motor busbar (U)	1
Motor busbar (V)	1
Motor busbar (W)	1
M5x16 thread-forming screw	3
M8x20 screw	3
Hex busbar	3
Nomex® tube	3
IGBT output busbar	3
300 A or 500 A current sensor	3
M4x10 thread-forming screw	6
M5 nut	2
Wire harness (current sensor cables)	1
Wire routing guide (500 A kit only)	1
M5x11 thread-cutting screw	6

Nomex® is a registered trademark of E.I. du Pont de Nemours and Company.

## 2 Disassembly

### 2.1 Safety Information

#### NOTICE

##### QUALIFIED PERSONNEL

Only qualified personnel are allowed to install the parts described in these installation instructions.

- Disassembly and reassembly of the drive must be done in accordance with the corresponding service guide.
- Use the standard fastener torque values in the service guide, unless the torque value is specified in these instructions.

#### ⚠ WARNING ⚠

##### ELECTRICAL SHOCK HAZARD

VLT® FC series drives contain dangerous voltages when connected to mains voltage. Improper installation, and installing or servicing with power connected, can cause death, serious injury, or equipment failure.

- Only use qualified electricians for the installation.
- Disconnect the drive from all power sources before installation or service.
- Treat the drive as live whenever the mains voltage is connected.
- Follow the guidelines in these instructions and local electrical safety codes.

#### ⚠ WARNING ⚠

##### DISCHARGE TIME (20 MINUTES)

The drive contains DC-link capacitors, which can remain charged even when the drive is not powered. High voltage can be present even when the warning indicator lights are off.

Failure to wait 20 minutes after power has been removed before performing service or repair work can result in death or serious injury.

- Stop the motor.
- Disconnect AC mains, permanent magnet type motors, and remote DC-link supplies, including battery back-ups, UPS, and DC-link connections to other drives.
- Wait 20 minutes for the capacitors to discharge fully before performing any service or repair work.
- Measure the voltage level to verify full discharge.

#### NOTICE

##### ELECTROSTATIC DISCHARGE

Electrostatic discharge can damage components.

- Ensure discharge before touching internal drive components, for example by touching a grounded, conductive surface or by wearing a grounded armband.

### 2.2 Removing the AC Input Busbars

To remove the AC input busbars, use the following steps. The AC input busbars can look different when the drive includes extra input options, such as an RFI filter or AC fuses.

1. Remove the air baffle by removing 4 screws (T25) and 2 nuts (13 mm).
2. Disconnect the customer input power wiring.
3. The next step differs based on the input options present in the drive. Go to the appropriate procedure, based on the options that are present:
  - a. No options
  - b. AC fuses only

- c. RFI filter only
- d. AC fuses and RFI filter

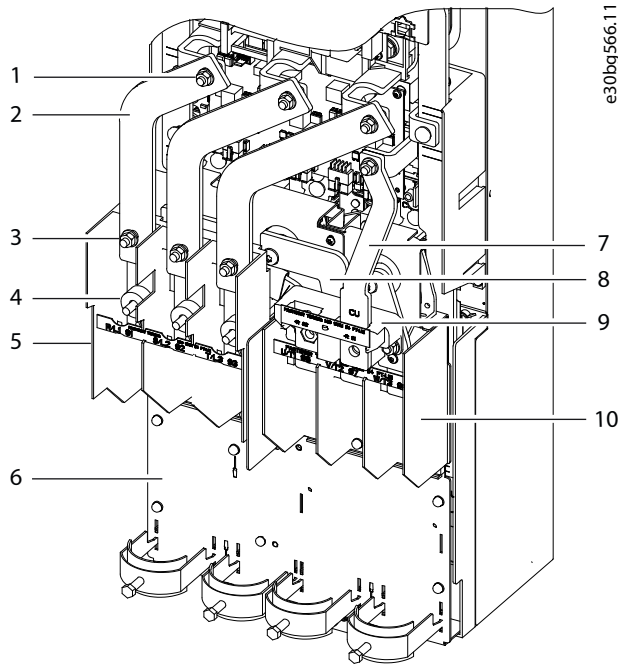

Illustration 1: AC Input Busbars with AC Fuse Configuration (Shown with Fuses Removed)

1	M8 nut (13 mm)	6	Power terminal mounting plate
2	AC input busbars	7	Brake busbar (optional)
3	M8 nut (13 mm)	8	U motor busbar
4	Fuse spacer	9	Brake terminal block (optional)
5	Mains terminal block	10	Motor terminal block

**No options**

1. Remove 3 M8 nuts (13 mm), 1 from the top of each AC input busbar.
2. Remove 3 M8 nuts (13 mm), 1 from the bottom of each AC input busbar.
3. Remove the AC input busbars from the drive.

**AC fuses only**

1. Remove 3 AC fuses by removing 6 M8 nuts (13 mm), 1 from each end of the fuses.
2. Remove 3 M8 nuts (13 mm), 1 from the top of each AC input busbar.
3. Remove the AC input busbars from the drive.

**RFI filter only**

1. Remove 3 M8 nuts (13 mm) from the top of the RFI filter, 1 per phase.
2. Remove 6 M8 nuts (13 mm) from the bottom of the RFI filter, 2 per phase.
3. Remove 4 M5x11 thread-cutting screws (T20), which connect the RFI filter to the side channels of the drive.
4. Unplug the RFI cable from the MK100 connector on the RFI card.
5. Lift the RFI filter from the drive.

**AC fuses and RFI filter**

1. Remove 3 AC fuses by removing 6 M8 nuts (13 mm), 1 from each end of the fuses.
2. Remove 3 M8 nuts (13 mm) from the top of the RFI filter, 1 per phase.
3. Remove 4 M5x11 thread-cutting screws (T20), which connect the RFI filter to the side channels of the drive.
4. Unplug the RFI cable from the MK100 connector on the RFI card.
5. Lift the RFI filter from the drive.

## 2.3 Removing the Mains Terminal Block

To remove the mains terminal block, use the following steps.

### Procedure

1. Disconnect the customer input power wiring.
2. Remove the R/S/T terminal label.
3. Remove 2 screws (T25) from the lower end of the mains terminal block.
4. Release the current sensor wiring from the cable clips.
5. Slide the mains terminal block downward to disengage it from the 2 metal clips on the power terminal mounting plate.

Discard the mains terminal block and terminal label.

## 2.4 Removing the Brake/Regen Terminal Block

If the drive includes either the brake option or regen/load share option, remove the terminal block using the following steps.

### Procedure

1. Disconnect the wiring for the brake option or regen/load share option.

The brake/regen terminals are labeled R(+) and R(-).

2. Remove the R(+) busbar:
  - a. Unfasten 1 thread-forming screw (T25) from the end of the busbar at the terminal block.
  - b. Unfasten 1 screw (T40) from the upper end of the busbar.
3. Remove the R(-) busbar:
  - a. Unfasten 1 thread-forming screw (T25) from the end of the busbar at the terminal block.
  - b. Unfasten 1 nut (13 mm) from the upper end of the busbar.
4. Remove 2 nuts (13 mm) from the brake terminal block.
5. Lift the brake/regen terminal block from the drive.

## 2.5 Removing the Motor Terminal Block

To remove the motor terminal block, use the following steps.

### Procedure

1. Disconnect wiring to the motor.
2. Remove the U/V/W terminal label.
3. Remove the EMC shield by removing 1 screw (T25).
4. Remove the 3 motor busbars (U/V/W):
  - a. Unfasten 3 thread-forming screws (T25), 1 from the middle of each busbar.
  - b. Unfasten 3 screws (T40), 1 from the top of each busbar.
5. Remove 3 Nomex® tubes and 3 cylinder busbars, 1 from the center of each current sensor.
6. Remove 2 screws (T25) from the lower end of the motor terminal block.
7. Remove the motor terminal block by sliding it down to release it from the 2 metal clips on the mounting plate.

Discard the motor terminal block, motor busbars, terminal label, cylinder busbars, and old Nomex® tubes.

## 2.6 Removing the Power Terminal Mounting Plate

To remove the power terminal mounting plate, use the following steps. Refer to [Illustration 2](#).

### Procedure

1. Remove 5 thread-cutting screws (T25) from the top of the plate.

The fan screw can remain in place, if present.

2. Remove 2 nuts (8 mm).
3. Unplug 3 current sensor cables, 1 from the back of each current sensor.
4. Unplug the current sensor wire harness from the power card, and discard it.
5. Lift the power terminal mounting plate, and unplug the mixing fan cable.

6. Remove the power terminal mounting plate from the drive.

Discard the power terminal mounting plate, current sensors, mixing fan, and fan housing.

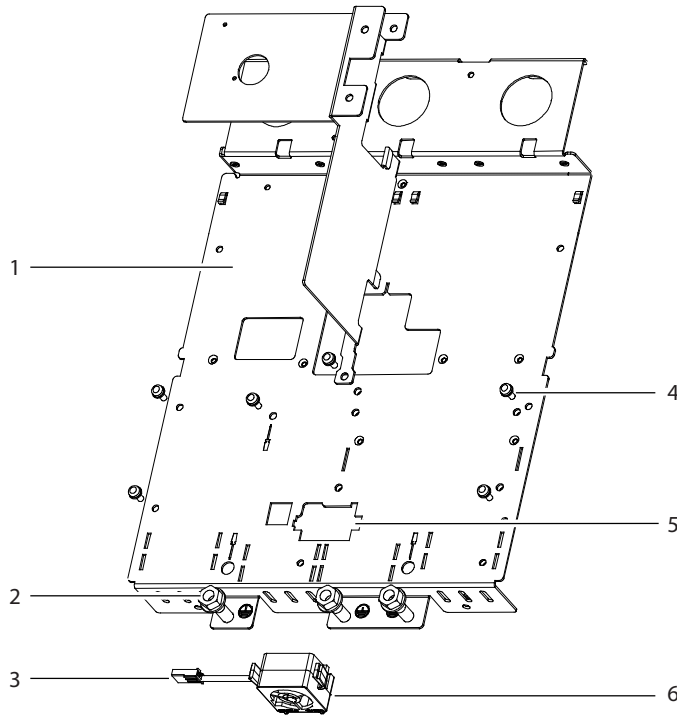

e30bx451.13

**Illustration 2: Power Terminal Mounting Plate**

1	Power terminal mounting plate	4	Screw (T25)
2	Nut (8 mm)	5	Mixing fan slot
3	Mixing fan cable	6	Mixing fan and housing

## 2.7 Removing the IGBT Output Busbars

To remove the IGBT output busbars, use the following steps.

### Procedure

1. Remove the gate drive card:
  - a. Unplug the cables from the connectors on the gate drive card.
  - b. Unfasten 5 thread-forming screws (T20) from the edges of the card.
2. Remove the 3 IGBT output busbars:
  - a. Unfasten 3 thread-forming screws (T20), 1 from the lower end of each IGBT output busbar.
  - b. Remove 6 screws (T40), 2 from each IGBT output busbar where they attach to the IGBT modules.

Discard the 3 IGBT output busbars.

### 3 Reassembly

#### 3.1 Kit Overview

##### Example

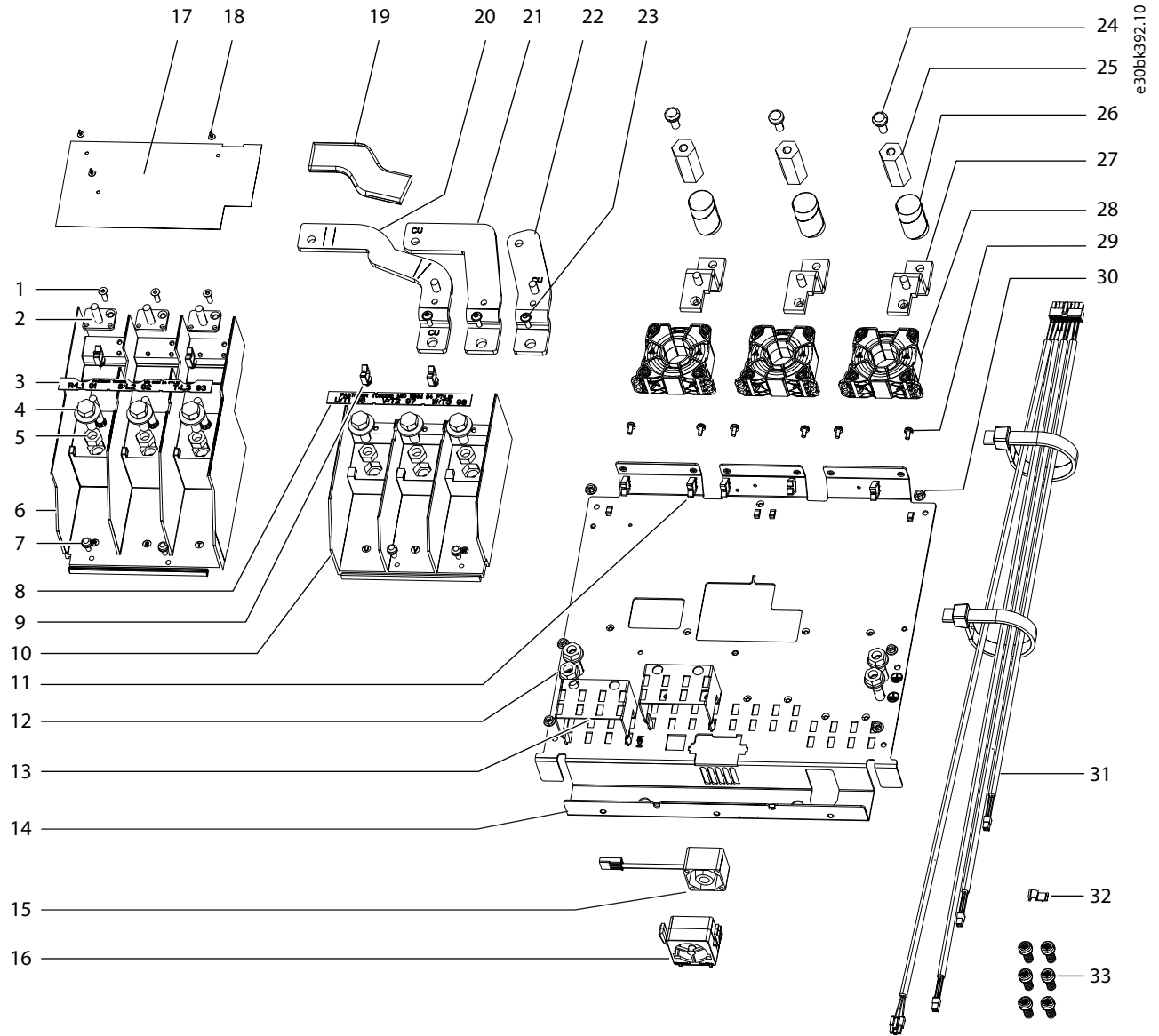

Illustration 3: Exploded View and Parts List of 300/500 A Current Sensor Kit

1	M5x16 countersunk screw	18	Plastic mounting button
2	Terminal plate	19	Busbar insulator sleeve (for U motor busbar)
3	R/S/T terminal label	20	Motor busbar (U)
4	M10x30 machine screw	21	Motor busbar (V)
5	M10 nut	22	Motor busbar (W)
6	Mains terminal block	23	M5x16 thread-forming screw
7	M5x12 screw	24	M8x20 screw
8	U/V/W terminal label	25	Hex busbar
9	Cable clip (blind hole)	26	Nomex® tube
10	Motor terminal block	27	IGBT output busbar
11	Cable clip (standard)	28	Current sensor
12	M10 flange nut	29	M4x10 thread-forming screw
13	Cable clamp bracket	30	M5 nut
14	Power terminal mounting plate (IP21/IP54)	31	Wire harness (current sensor cables)
15	Mixing fan	32	Wire routing guide (500 A kit only)
16	Mixing fan housing	33	M5x11 thread-forming screws
17	Insulator sheet (EMC shield)		

### 3.2 Installing the IGBT Output Busbars

To install the new IGBT output busbars, use the following steps.

#### Procedure

1. Install the new IGBT output busbars:

- a. Position the 3 new IGBT output busbars in the drive.

The new IGBT output busbars have PEM studs at the lower end rather than holes for fasteners.

- b. Fasten 6 screws (T40), 2 at the top of each IGBT output busbar where it connects to an IGBT module.

2. Install the gate drive card:

- a. Fasten 5 thread-forming screws (T20) in the edges of the gate drive card.
- b. Reattach the cables to the connectors on the card.



### 3.3 Installing the Current Sensors

To install the new current sensors on the power terminal mounting plate, use the following steps. See [Illustration 4](#).

## NOTICE

#### MOUNTING PLATE SELECTION

The 300/500 A current sensor kit includes 2 power terminal mounting plates. Select the correct plate for the enclosure:

- [Illustration 3](#) shows the plate for IP21/Type 1 and IP54/Type 12 enclosures.
- [Illustration 4](#) shows the plate for IP20/Chassis enclosures.

#### Procedure

1. Position the 3 new current sensors at the top of the power terminal mounting plate.

The cable connectors on the current sensors face the back of the drive, and the airflow arrows point toward the front of the drive.

2. Fasten 6 M4x10 thread-forming screws (T20), 2 in the base of each current sensor.

Torque screws to 2.0 Nm (17.7 in-lb).

3. Connect the wire harness by attaching 3 current sensor cables to the back of the current sensors, 1 per current sensor.
4. Route the current sensor cables through the cable clips and guides on the power terminal mounting plate.

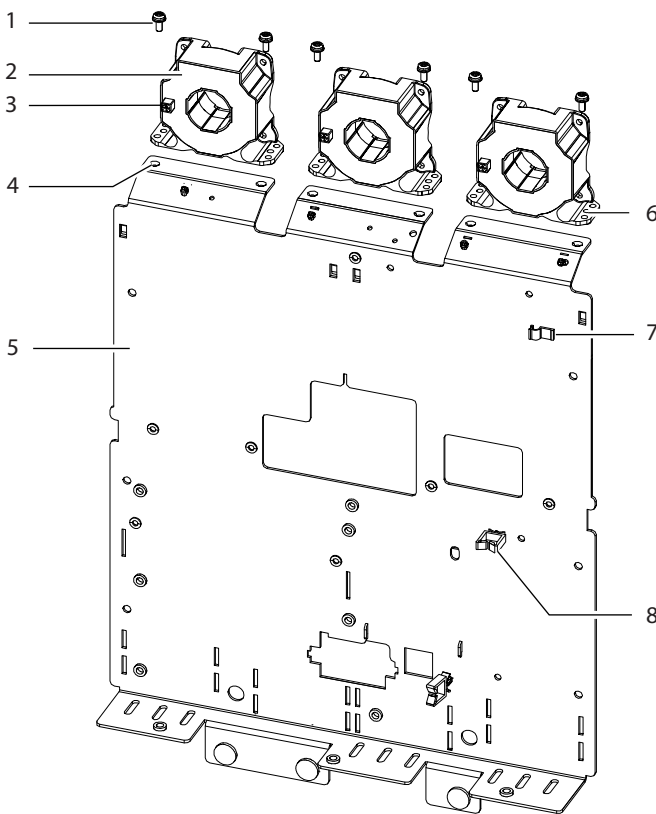

e30bg565.11

Illustration 4: Back View of Power Terminal Mounting Plate and Current Sensors

1	M4x10 thread-forming screw	5	Power terminal mounting plate
2	Current sensor	6	Mounting hole
3	Current sensor cable connector	7	Wire routing guide (500 A kit only)
4	Mounting hole	8	Cable clip

### 3.4 Installing the Power Terminal Mounting Plate

To install the new power terminal mounting plate and mixing fan, use the following steps.

#### Procedure

1. Position the power terminal mounting plate in the drive.
2. Fasten the plate with 7 M5x11 thread-cutting screws (T25).
3. Connect the wire harness to the MK100 connector on the power card.
4. Connect the mixing fan cable to the fan cable connector.
5. Insert the mixing fan into the new fan housing with the label facing the open side of the housing.
6. With the fan label facing up, snap the mixing fan assembly into the slot in the plate.

When the fan is properly seated, the fan assembly is level with the plate.

7. For IP21/Type 1 and IP54/Type 12 enclosures, fasten 4 M10 flange nuts (17 mm) to the ground points marked at the sides of the power terminal mounting plate.
8. For IP20/Chassis enclosures, fasten 3 M10 flange nuts (17 mm) to the ground points marked at the bottom of the power terminal mounting plate.

### 3.5 Installing the Motor Terminal Block

To install the new motor terminal block, hex busbars, and motor busbars, use the following steps.

#### Procedure

1. Position the motor terminal block by sliding it upward under the 2 metal clips on the power terminal mounting plate.
2. Fasten 2 M5x12 screws (T25) at the lower end of the motor terminal block.
3. Place the 3 hex busbars in the drive and tighten the hex busbars onto the PEM studs on the 3 IGBT output busbars.

For 300 A current sensor kits, torque the hex busbars to 9.6 Nm (85 in-lb).  
For 500 A current sensor kits, torque the hex busbars to 19.1 Nm (169 in-lb).

4. Place 3 Nomex® tubes in the drive, 1 around each hex busbar.
5. Install the 3 motor busbars (U/V/W):
  - a. Slide the insulator sleeve over the U busbar.
  - b. Secure 3 screws (T30), 1 at the end of each motor busbar fastening it to a hex busbar.
  - c. Fasten 3 thread-forming screws (T25), 1 in the middle of each motor busbar.
6. Using the 3 plastic mounting buttons from the kit, attach the new EMC insulator sheet to the EMC shield.
7. Position the EMC shield between the mains terminal block and motor terminal block and secure with 1 screw (T25).
8. Reconnect wiring to the motor terminals.
9. Attach the U/V/W terminal label.

### 3.6 Installing the Brake/Regen Terminal Block

If the brake option or regen/load share option is present, reinstall the brake/regen terminal block using the following steps.

#### Procedure

1. Position the brake/regen terminal block in the drive on top of the motor terminal block.
2. Fasten 2 nuts (13 mm) in the block.
3. Install the R(-) busbar:
  - a. Fasten 1 M8 nut (13 mm) at the upper end of the busbar.
  - b. Fasten 1 thread-forming screw (T25) in the busbar at the terminal block.
4. Install the R(+) busbar:
  - a. Fasten 1 screw (T40) at the upper end of the busbar.
  - b. Fasten 1 thread-forming screw (T25) in the busbar at the terminal block.
5. Reconnect the brake or regen/load share wiring.

### 3.7 Installing the Mains Terminal Block

To install the new mains terminal block, use the following steps.

#### Procedure

1. Place the mains terminal block in position by sliding it under the 2 metal clips on the power terminal mounting plate.
2. Fasten 2 screws (T25) in the lower end of the mains terminal block.
3. Route the current sensor wiring through the cable clips.
4. Attach the new R/S/T terminal label.

### 3.8 Installing the AC Input Busbars

To reinstall the AC input busbars, use the following steps. The procedure differs based on the input options present in the drive. Select the appropriate procedure for the drive:

- No options.
- AC fuses only.
- RFI filter only.
- AC fuses and RFI filter.

#### No options

1. Position the 3 AC input busbars in the drive.
2. Fasten 3 nuts (13 mm), 1 in the top of each AC input busbar.
3. Fasten 3 nuts (13 mm), 1 at the bottom of each AC input busbar.
4. Connect the customer input power wiring.
5. Position the air baffle, and fasten with 4 screws (T25) and 2 nuts (13 mm).

#### AC fuses only

1. Position the AC input busbars in the drive.
2. Fasten 3 nuts (13 mm), 1 at the top of each AC input busbar.
3. Position the 3 AC fuses in the drive.
4. Fasten 6 nuts (13 mm), 1 at each end of the 3 fuses.
5. Connect the customer input power wiring.
6. Position the air baffle, and fasten with 4 screws (T25) and 2 nuts (13 mm).

#### RFI filter only

1. Connect the RFI cable to MK100 on the RFI filter card.
2. Position the RFI filter in the drive.
3. Fasten 4 M5x11 thread-cutting screws (T20), connecting the RFI filter to the side channels of the drive.

If needed, use the extra M5x11 thread-cutting screws from the kit.

4. Secure 3 nuts (13 mm) at the top of the RFI filter, 1 per phase.
5. Secure 6 nuts (13 mm) at the bottom of the RFI filter, 2 per phase.
6. Connect the customer input power wiring.
7. Position the air baffle, and fasten with 4 screws (T25) and 2 nuts (13 mm).

#### AC fuses and RFI filter

1. Connect the RFI cable to MK100 on the RFI card.
2. Position the RFI filter in the drive.
3. Fasten 4 M5x11 thread-cutting screws (T20), connecting the RFI filter to the side channels of the drive.

If needed, use the extra M5x11 thread-cutting screws from the kit.

4. Secure 3 nuts (13 mm) at the top of the RFI filter, 1 per phase.
5. Install 3 AC fuses using 6 nuts (13 mm), 1 at each end of the 3 fuses.
6. Connect the customer input power wiring.
7. Position the air baffle, and fasten with 4 screws (T25) and 2 nuts (13 mm).

**Danfoss A/S**  
Ulsnaes 1  
DK-6300 Graasten  
[vlt-drives.danfoss.com](http://vlt-drives.danfoss.com)

.....  
Danfoss can accept no responsibility for possible errors in catalogs, brochures, and other printed material. Danfoss reserves the right to alter its products without notice. This also applies to products already on order provided that such alterations can be made without subsequential changes being necessary in specifications already agreed. All trademarks in this material are property of the respective companies. Danfoss and the Danfoss logotype are trademarks of Danfoss A/S. All rights reserved.  
.....

