

300 A Current Sensor Kit for D1h/D3h/D5h/D6h Drives

VLT® FC Series FC 102, FC 103, FC 202, FC 302

1 Overview

1.1 Description

The 300 A current sensor kit contains all components required to upgrade the current sensor assembly in D1h/D3h/D5h/D6h drives. The kit is compatible with the power ratings shown in [Table 1](#). The power rating of the drive is listed on the nameplate as characters 7–10 of the type code (T/C).

Table 1: Applicable Power Range for 300 A Current Sensor Kit

Product group and series	Voltage rating	Power rating [kW (hp)]
VLT® HVAC Drive FC 102	(T4) 380–480 V	110–160 (150–250)
VLT® Refrigeration Drive FC 103 VLT® AQUA Drive FC 202	(T7) 525–690 V	75–160 (75–200)
VLT® AutomationDrive FC 302	(T5) 380–500 V	90–132 (125–200)
	(T7) 525–690 V	55–132 (60–150)

1.2 Kit Number

Table 2: Number for 300 A Current Sensor Kit

Kit number	Kit description
176F6516	300 A Current Sensor Conversion Kit for D1h/D3h/D5h/D6h

1.3 Items Supplied

[Table 3](#) provides a list of items included in the 300 A current sensor kit. Refer also to [Illustration 4](#).

Table 3: Items Supplied in 300 A Current Sensor Kit

Item	Quantity
EMC shield	1
M8 flange nut	3
M5x16 countersunk screw	3
Terminal plate	3
R/S/T terminal label	1
M10x30 machine screw	6
M10 hex nut	6
Mains terminal block	1
M5x12 screw	11
M5x16 thread-forming screw	3
U/V/W terminal label	1
Motor terminal block	1

Item	Quantity
Power terminal mounting plate (IP21/IP54)	1
Power terminal mounting plate (IP20/Chassis)	1
Mixing fan	1
Mixing fan housing	1
Insulator sleeve (for U motor busbar)	1
Motor busbar (U)	1
Motor busbar (V)	1
Motor busbar (W)	1
IGBT output busbar	3
Hex busbar support bracket	1
M6 nut	3
M6x24 screw	3
Hex busbar	3
Nomex® tube	3
300 A current sensor	3
M4x10 thread-forming screw	6
Wire harness (current sensor cables)	1
M5x11 thread-forming screw	4

Nomex® is a registered trademark of E.I. du Pont de Nemours and Company.

2 Disassembly

2.1 Safety Information

NOTICE

QUALIFIED PERSONNEL

Only qualified personnel are allowed to install the parts described in these installation instructions.

- Disassembly and reassembly of the drive must be done in accordance with the corresponding service guide.
- Use the standard fastener torque values in the service guide, unless the torque value is specified in these instructions.

⚠ WARNING ⚠

ELECTRICAL SHOCK HAZARD

VLT® FC series drives contain dangerous voltages when connected to mains voltage. Improper installation, and installing or servicing with power connected, can cause death, serious injury, or equipment failure.

- Only use qualified electricians for the installation.
- Disconnect the drive from all power sources before installation or service.
- Treat the drive as live whenever the mains voltage is connected.
- Follow the guidelines in these instructions and local electrical safety codes.

⚠ WARNING ⚠

DISCHARGE TIME (20 MINUTES)

The drive contains DC-link capacitors, which can remain charged even when the drive is not powered. High voltage can be present even when the warning indicator lights are off.

Failure to wait 20 minutes after power has been removed before performing service or repair work can result in death or serious injury.

- Stop the motor.
- Disconnect AC mains, permanent magnet type motors, and remote DC-link supplies, including battery back-ups, UPS, and DC-link connections to other drives.
- Wait 20 minutes for the capacitors to discharge fully before performing any service or repair work.
- Measure the voltage level to verify full discharge.

NOTICE

ELECTROSTATIC DISCHARGE

Electrostatic discharge can damage components.

- Ensure discharge before touching internal drive components, for example by touching a grounded, conductive surface or by wearing a grounded armband.

2.2 Removing the AC Input Busbars

To remove the AC input busbars, use the following steps. The AC input busbars can look different when the drive includes extra input options, such as an RFI filter or AC fuses. [Illustration 1](#) shows the AC input busbars with no input options. [Illustration 2](#) shows the AC input busbars with optional RFI filter and AC fuses.

Procedure

1. Remove the air baffle by removing 4 screws (T25) and 2 lower screws (T40).

If the brake option is present, there are no lower screws.

2. The next step differs based on the input options present in the drive. Go to the appropriate procedure, based on the options that are present:
 - a. No options
 - b. AC fuses only
 - c. RFI filter only
 - d. AC fuses and RFI filter

No options

1. Remove 3 M8 nuts (13 mm) at the top of the AC input busbars, 1 per phase.
2. Remove 3 M8 nuts (13 mm) at the bottom of the AC input busbars, 1 per phase.
3. Remove 1 M8 nut (13 mm) from the center busbar.
4. Remove the busbars from the drive.

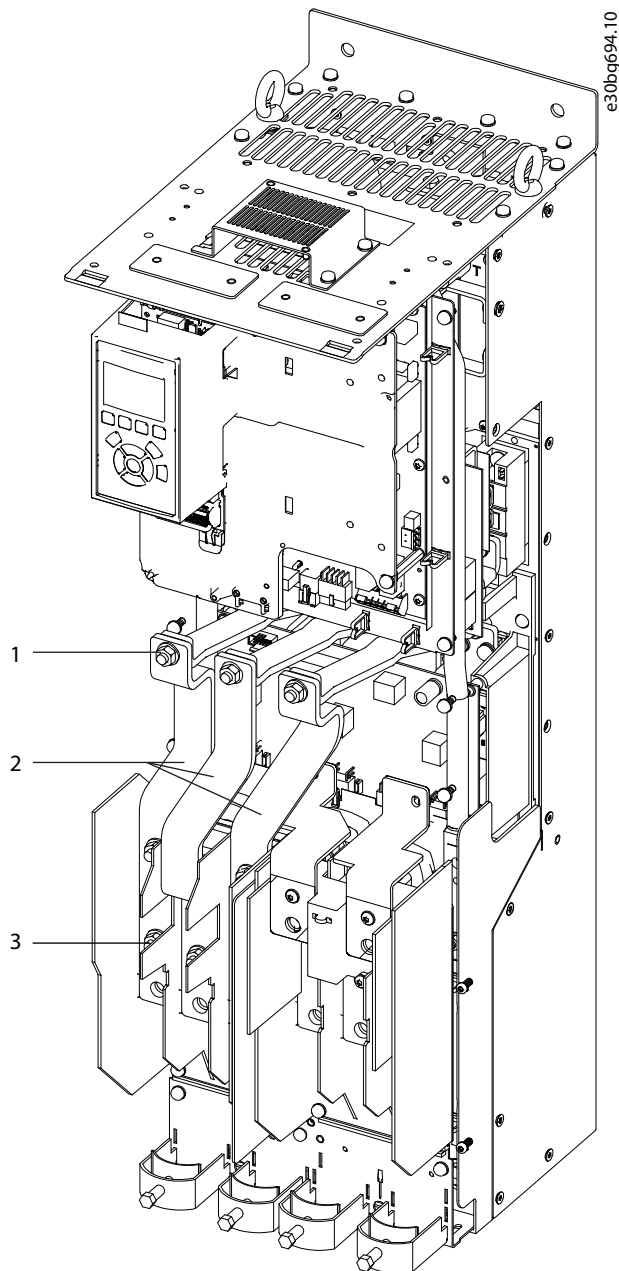
**Illustration 1: AC Input Busbars (with No Options)**

1	M8 nut (13 mm)	3	M8 nut (13 mm)
2	AC input busbars		

AC fuses only

1. Remove AC fuses by removing 6 M8 nuts (13 mm), 1 at each end of the 3 fuses.
2. Remove the AC fuses from the drive.
3. Remove 3 M8 nuts (13 mm) at the top of the AC input busbars, 1 per phase.
4. Remove the AC input busbars.

RFI filter only

1. Remove 3 M8 nuts (13 mm) at the top of the RFI filter, 1 per phase.
2. Remove 6 M8 nuts (13 mm) at the bottom of the RFI filter, 2 per phase.
3. Remove 4 M5x11 screws (T20) connecting the RFI filter to the side channels of the drive.
4. Remove the RFI filter and unplug the RFI cable from MK100 on the RFI filter card.

AC fuses and RFI filter

1. Remove the AC fuses by removing 6 M8 nuts (13 mm), 1 at each end of the 3 AC fuses.
2. Remove 3 M8 nuts (13 mm) at the top of the RFI filter, 1 per phase.
3. Remove 4 M5x11 screws (T20) connecting the RFI filter to the side channels of the drive.
4. Remove the RFI filter and unplug the RFI cable from MK100 on the RFI card.

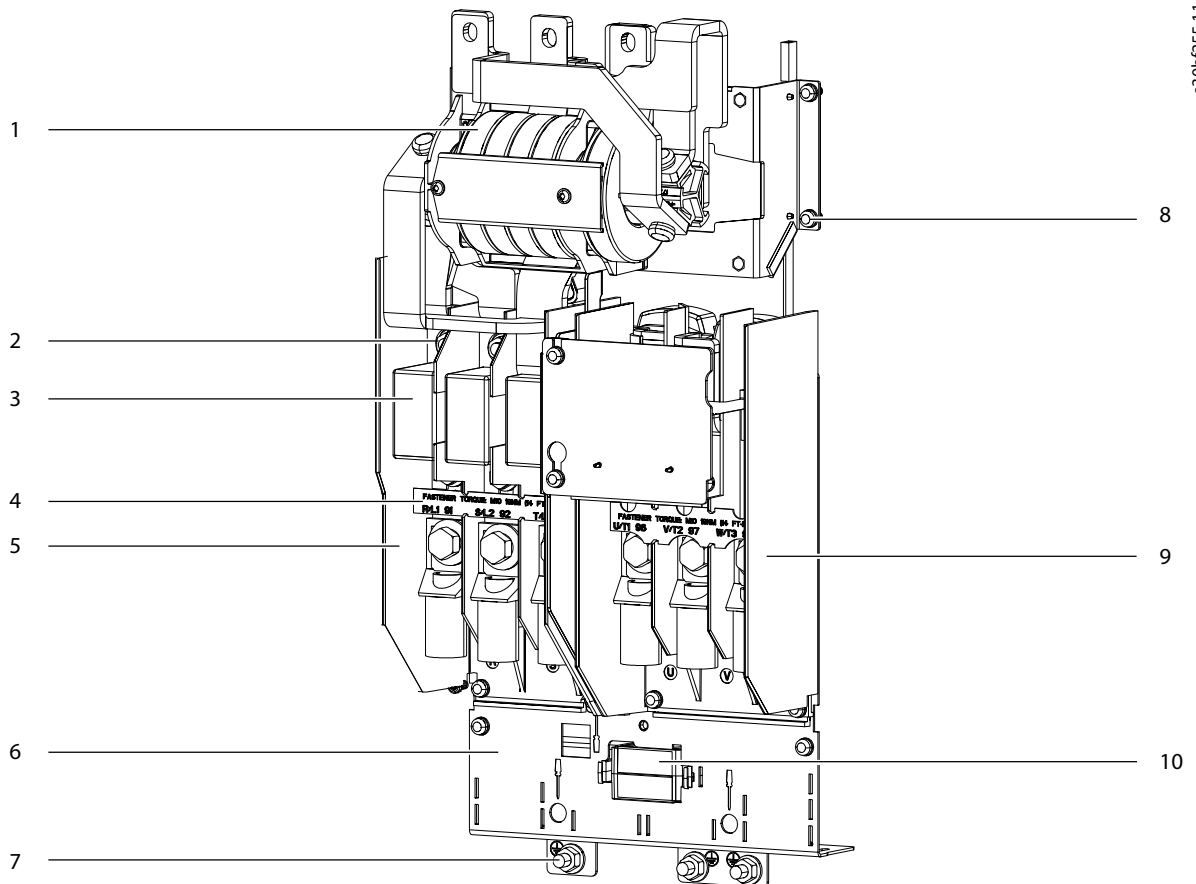

e30b255.11

Illustration 2: AC Input Busbars with Optional AC Fuses and RFI Filter

1	RFI filter (optional)	6	Power terminal mounting plate
2	M8 nut (13 mm)	7	M8 nut (13 mm)
3	AC fuse (optional)	8	M5x11 screw (T20)
4	R/S/T terminal label	9	Motor terminal block
5	Mains terminal block	10	Mixing fan

2.3 Removing the Mains Terminal Block

To remove the mains terminal block, use the following steps.

Procedure

1. Disconnect the customer input power wiring.
2. Remove the R/S/T terminal label.
3. Remove 2 screws (T25) at the bottom of the mains terminal block.

If necessary, also remove 1 screw (T25) from the EMC shield near the lower end of the terminal block.

4. Slide the mains terminal block down to release it from the 2 metal clips on the mounting plate.

Discard the mains terminal block and terminal label.

2.4 Removing the Brake/Regen Terminal Block

If the drive includes either the brake option or regen/load share option, remove the terminal block using the following steps.

Procedure

1. Disconnect the wiring for the brake option or regen/load share option.

The brake/regen terminals are labeled R(+) and R(-).

2. Remove the R(+) busbar:
 - a. Unfasten 1 M4x8 thread-forming screw (T20) from the busbar at the terminal block.
 - b. Unfasten 1 screw (T40) at the upper end of the busbar.
3. Remove the R(-) busbar:
 - a. Unfasten 1 M4x8 thread-forming screw (T20) from the busbar at the terminal block.
 - b. Unfasten 1 M8 nut (13 mm) at the upper end of the busbar.
4. Remove 2 screws (T40) from the brake/regen terminal block.
5. Remove the brake/regen terminal block from the drive.

2.5 Removing the Motor Terminal Block

Procedure

1. Disconnect wiring to the motor.
2. Remove the U/V/W terminal label.
3. Remove the EMC shield:
 - a. Unfasten 2 screws (T25) from the base of the EMC shield.
 - b. Release the current sensor wiring from the cable clips on the EMC shield.
4. Remove the U motor busbar:
 - a. Remove 1 thread-forming screw (T25) from the middle of the busbar.
 - b. Unfasten 1 screw (T30) at the current sensor end of the busbar.
5. Remove the V motor busbar:
 - a. Remove 1 thread-forming screw (T25) from the middle of the busbar.
 - b. Unfasten 1 screw (T30) at the current sensor end of the busbar.

The V screw is shorter than the U and W screws.

6. Remove the W motor busbar:

Remove 1 thread-forming screw (T25) from the middle of the busbar.

- **b.** Unfasten 1 screw (T30) at the current sensor end of the busbar.
7. Remove 2 screws (T25) from the lower end of the motor terminal block.
 8. Remove the motor terminal block by sliding it down to release it from the 2 metal clips on the mounting plate.
 9. Remove 3 Nomex® tubes, 1 from the center of each current sensor.
 10. Remove 3 cylinder busbars, 1 from the center of each current sensor.

Discard the old Nomex® tubes, current sensor cylinder busbars, motor terminal block, and U/V/W motor busbars.

2.6 Removing the Power Terminal Mounting Plate

To remove the power terminal mounting plate, use the following steps. Refer to [Illustration 3](#).

Procedure

1. Remove the mixing fan from the slot in the power terminal mounting plate:
 - **a.** Place the end of a screwdriver under each of the mixing fan release tabs.
 - **b.** Lift to free the fan and housing from the power terminal mounting plate.
 - **c.** Unplug the mixing fan in-line cable connector.
2. Remove 4 thread-cutting screws (T20), 2 from each side of the power terminal mounting plate.
3. For IP21/Type 1 and IP54/Type 12 enclosures only, loosen 3 screws (T25) at the bottom of the drive.
4. For IP20/Chassis enclosures only, remove 3 nuts (10 mm) from the lower edge of the plate.
5. Unplug 3 current sensor cables, 1 from the back of each current sensor.
6. Unplug the 16-pin connector from MK101 on the power card.

Discard the current sensor wire harness.

7. Remove the power terminal mounting plate with the old current sensors attached.

Discard the power terminal mounting plate and current sensors. Retain the fasteners for reuse during kit installation.

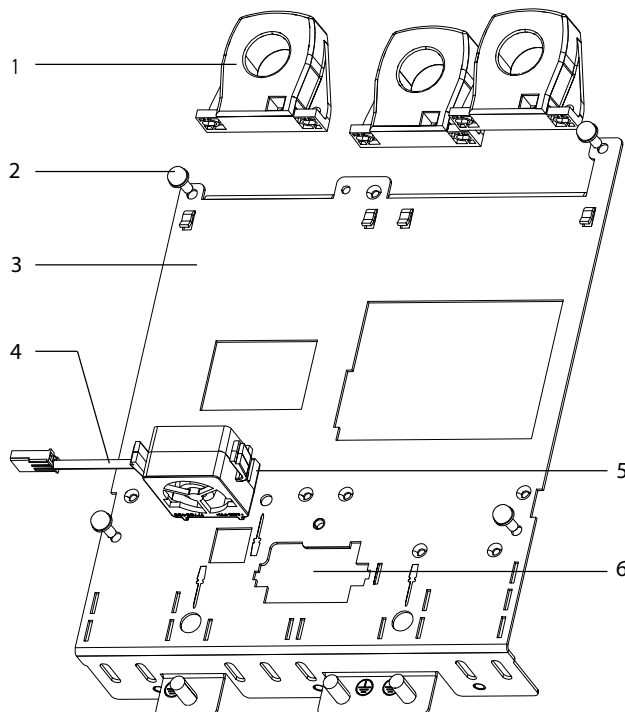

Illustration 3: Power Terminal Mounting Plate

1	Current sensor	4	Mixing fan cable
2	Thread-cutting screw (T20)	5	Mixing fan
3	Power terminal mounting plate	6	Mixing fan slot

2.7 Removing the IGBT Output Busbars

To remove the IGBT output busbars, use the following steps.

Procedure

1. Remove the control card mounting plate:
 - a. Disconnect the customer control wiring.
 - b. Remove 4 screws (T20) from the corners of the control card mounting plate.
 - c. Lift the control card mounting plate from the drive, and unplug the ribbon cable connecting the control card and power card.
2. Remove the power card mounting plate:
 - a. Disconnect all cables from the power card, and free the cables from the cable clips on the mounting plate.
 - b. Remove 4 screws (T20) from the corners of the mounting plate.
 - c. Remove 1 screw (T25) from the top center of the mounting plate.
3. Remove the DC bus rails:
 - a. Remove 2 nuts (10 mm) from the lower end of the DC bus rails, 1 per bus rail.
 - b. Remove 2 screws (T30) from the top end of the DC bus rails, 1 per bus rail.
4. Remove the gate drive card:
 - a. Disconnect all cables on the gate drive card.
 - b. Unfasten 6 thread-forming screws (T20) from the edges of the card.
5. Remove the cylinder busbar support bracket:
 - a. Unfasten 3 M6 screws (T30) from the cylinder busbar support bracket.
 - b. Remove the bracket from the drive, and discard it.
6. Remove the 3 IGBT output busbars:
 - a. Remove 3 thread-forming screws (T25), 1 from the top of each IGBT output busbar.
 - b. Remove 6 screws (T30), 2 from the top of each busbar.

Discard the IGBT output busbars.

3 Reassembly

3.1 Kit Overview

Example

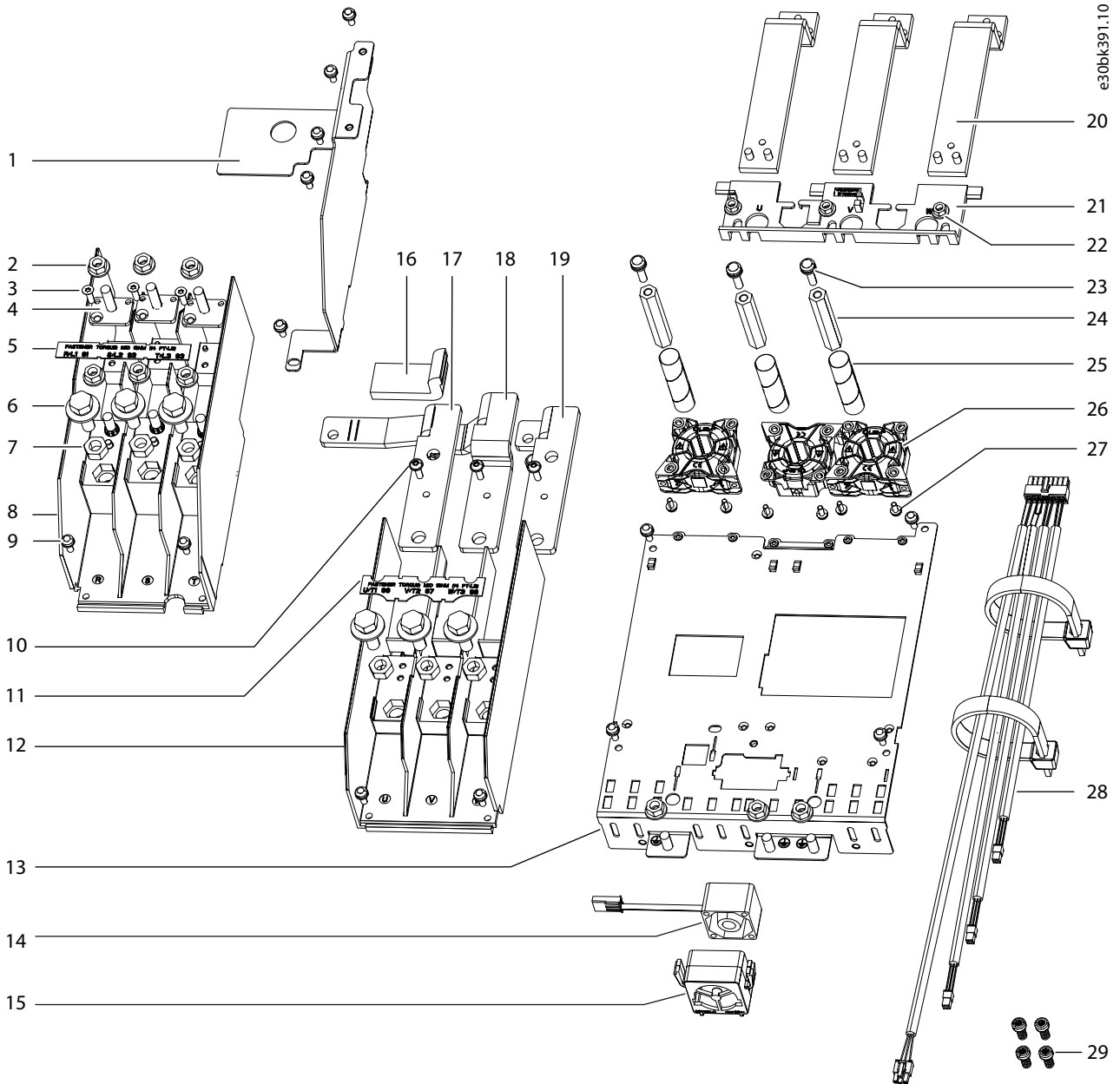

Illustration 4: Exploded View and Parts List of 300 A Current Sensor Kit

1	EMC shield	16	Insulator sleeve (U motor busbar)
2	M8 flange nut	17	Motor busbar (U)
3	M5x16 countersunk screw	18	Motor busbar (V)
4	Terminal plate	19	Motor busbar (W)
5	R/S/T terminal label	20	IGBT output busbars
6	M10x30 machine screw	21	Hex busbar support bracket
7	M10 hex nut	22	M6 nut
8	Mains terminal block	23	M6x24 screw
9	M5x12 screw	24	Hex busbar
10	M5x16 thread-forming screw	25	Nomex® tube
11	U/V/W terminal label	26	Current sensor
12	Motor terminal block	27	M4x10 thread-forming screw
13	Power terminal mounting plate (IP21/IP54)	28	Wire harness (current sensor cables)
14	Mixing fan	29	M5x11 thread-forming screws (spare fasteners)
15	Mixing fan housing		Not shown: Power terminal mounting plate (IP20/Chassis)

3.2 Installing the IGBT Output Busbars

To install the new IGBT output busbars, use the following steps.

Procedure

1. Install the 2 new IGBT output busbars:
 - a. Position the 3 new IGBT output busbars in the drive.

The new IGBT output busbars have PEM studs at the bottom rather than holes for fasteners.
 - b. Fasten 6 screws (T30), 2 at the top of each IGBT output busbar.
 - c. Fasten 3 thread-forming screws (T25), 1 at the top of each IGBT output busbar.
2. Install the new hex busbar support bracket:
 - a. Position the bracket over the 3 IGBT output busbars.
 - b. Fasten 3 M5 nuts (8 mm) to secure the bracket.
3. Install the gate drive card:
 - a. Fasten 6 thread-forming screws (T20) in the edges of the card.
 - b. Reconnect all cables to the gate drive card connectors.
4. Install the DC bus rails:
 - a. Fasten 2 screws (T30) in the top end of the DC bus rails, 1 per bus rail.
 - b. Fasten 2 nuts (10 mm) in the lower end of the DC bus rails, 1 per bus rail.
5. Install the power card mounting plate:
 - a. Secure 4 screws (T20) in the corners of the mounting plate.
 - b. Fasten 1 screw (T25) at the top center of the mounting plate.
 - c. Reconnect all cables to the power card, and route the cables through the cable clips on the mounting plate.
6. Install the control card mounting plate.
 - a. Reconnect the ribbon cable connecting the control card and power card, and position the control card mounting plate in the drive.
 - b. Secure 4 screws (T20) in the corners of the control card mounting plate.
 - c. Reconnect the customer control wiring.

3.3 Installing the Current Sensors

To install the new current sensors on the power terminal mounting plate, use the following steps. Refer to [Illustration 5](#).

NOTICE

MOUNTING PLATE SELECTION

The 300 A current sensor kit includes 2 power terminal mounting plates. Select the correct plate for the enclosure:

- [Illustration 4](#) shows the plate for IP21/Type 1 and IP54/Type 12 enclosures.
- [Illustration 5](#) shows the plate for IP20/Chassis enclosures.

Procedure

1. Position the outer 2 current sensors at the top of the power terminal mounting plate with the base against the plate.
2. Invert the middle current sensor so that the base is at the top.
3. Align the current sensors so that the cable connectors face the back of the unit, and the arrows on the sensors point outward.
4. Attach 3 current sensors to the power terminal mounting plate by fastening 6 thread-forming screws (T20), 2 per sensor.

Torque screws to 2.0 Nm (17.7 in-lb).

5. Connect the wire harness by attaching 3 current sensor cables to the back of the current sensors, 1 per current sensor.
6. Attach the 16-pin connector to MK101 on the power card.
7. Route the current sensor cables through the cable guides on the power terminal mounting plate.

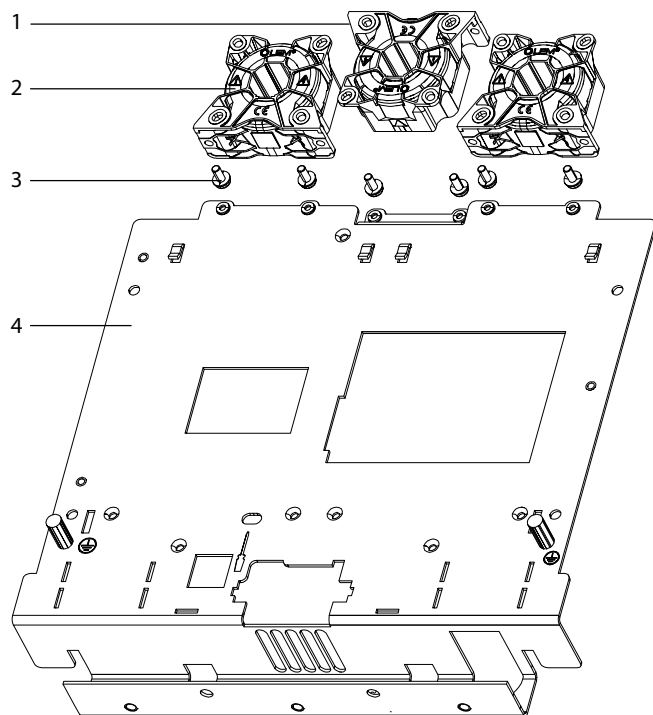

e30bg562.11

Illustration 5: Current Sensor Mounting Position

1	Middle current sensor (inverted position)	3	Thread-forming screw (T20)
2	Outer current sensor (upright position)	4	Power terminal mounting plate (IP20/Chassis)

3.4 Installing the Power Terminal Mounting Plate

To install the power terminal mounting plate, use the following steps.

Procedure

1. Position the power terminal mounting plate in the drive.
2. Fasten 4 thread-cutting screws (T20), 2 screws in each side of the plate.

3. Attach the mixing fan cable in-line connector.
4. Insert the mixing fan into the fan housing with the label facing the open side of the housing.
5. With the mixing fan label facing up, snap the mixing fan assembly into the slot in the power terminal mounting plate.
6. For IP21/Type 1 and IP54/Type 12 enclosures only, fasten 3 screws (T25) at the bottom of the drive.
7. For IP20/Chassis enclosures only, fasten 3 M8 nuts.

3.5 Installing the Motor Terminal Block

To install the motor terminal block, use the following steps. Refer to [3.1 Kit Overview](#).

Procedure

1. Position the motor terminal block by sliding it upward under the 2 metal clips on the power terminal mounting plate.
2. Fasten 2 screws (T25) at the lower end of the motor terminal block.
3. Tighten the hex busbars onto the PEM studs on the IGBT output busbars.

The shorter hex busbar is the middle hex busbar (V). Torque to 9.6 Nm (85 in-lb).

4. Place 3 Nomex® tubes in the drive, 1 around each hex busbar at the center of the 3 current sensors.

Place the shorter tube (marked with a red line) around the middle hex busbar.

5. Install the W motor busbar:
 - a. Fasten 1 screw (T30) in the current sensor end of the busbar.
 - b. Fasten 1 thread-forming screw (T25) in the middle of the busbar.
6. Install the V motor busbar:
 - a. Fasten 1 screw (T30) in the current sensor end of the busbar.

The V screw is shorter than the U and W screws.

 - b. Fasten 1 thread-forming screw (T25) in the middle of the busbar.
7. Install the U motor busbar:
 - a. Slide the insulator sleeve over the U busbar.
 - b. Fasten 1 screw (T30) in the current sensor end of the busbar.
 - c. Fasten 1 thread-forming screw (T25) in the middle of the busbar.
8. Position the new EMC shield between the mains terminal block and motor terminal block and secure with 2 screws (T25).
9. Reconnect wiring to the motor terminals.
10. Attach the U/V/W terminal label.

3.6 Installing the Brake/Regen Terminal Block

If the brake option or regen/load share option is present, reinstall the brake/regen terminal block using the following steps.

Procedure

1. Position the brake/regen terminal block in the drive on top of the motor terminal block.
2. Secure 2 screws (T40) in the terminal block.
3. Install the R(-) busbar:
 - a. Fasten 1 M8 nut (13 mm) at the upper end of the busbar.
 - b. Fasten 1 M4x8 thread-forming screw (T20) in the busbar at the terminal block.
4. Install the R(+) busbar:
 - a. Fasten 1 screw (T40) at the upper end of the busbar.
 - b. Fasten 1 thread-forming screw (T25) in the busbar at the terminal block.
5. Reconnect the brake or regen/load share wiring.

3.7 Installing the Mains Terminal Block

To install the mains terminal block, use the following steps. Refer to [3.1 Kit Overview](#).

Procedure

1. Place the mains terminal block in position by sliding it under the 2 metal clips on the power terminal mounting plate.
2. Secure 2 screws (T25) in the lower end of the mains terminal block.
3. If removed previously, fasten 1 screw (T25) in the EMC shield below the terminal block.

4. Reconnect the customer input wiring.
5. Mount the new R/S/T terminal label.

3.8 Installing the AC Input Busbars

To install the AC input busbars, use the following steps. The AC input busbars can look different when the drive includes extra input options, such as an RFI filter or AC fuses. [Illustration 1](#) shows the drive with no input options. [Illustration 2](#) shows the AC input busbars with AC fuses and RFI filter options.

The next procedure differs based on the input options present in the drive. Select the appropriate procedure for the drive:

- No options.
- AC fuses only.
- RFI filter only.
- AC fuses and RFI filter.

No options

1. Position the 3 AC input busbars in the drive.
2. Fasten 1 M8 nut (13 mm) in the center of the middle busbar.
3. Secure 6 M8 nuts (13 mm) at the bottom of the AC input busbars, 1 per phase.
4. Fasten 3 M8 nuts (13 mm) at the top of the AC input busbars, 1 per phase.
5. Position the air baffle in the drive, and fasten with 4 screws (T25).

AC fuses only

1. Position the AC input busbars in the drive.
2. Fasten 3 M8 nuts (13 mm) at the top of the AC input busbars, 1 per phase.
3. Position the 3 AC fuses in the drive.
4. Fasten 6 M8 nuts (13 mm), 1 at each end of the 3 fuses.
5. Position the air baffle in the drive, and fasten with 4 screws (T25).

RFI filter only

1. Connect the RFI cable to MK100 on the RFI filter card.
2. Position the RFI filter in the drive.
3. Fasten 4 M5x11 thread-cutting screws (T20), connecting the RFI filter to the side channels of the drive.

If needed, use the extra M5x11 thread-cutting screws from the kit.

4. Secure 6 M8 nuts (13 mm) at the bottom of the RFI filter, 2 per phase.
5. Secure 3 M8 nuts (13 mm) at the top of the RFI filter, 1 per phase.
6. Position the air baffle in the drive, and fasten with 4 screws (T25).

AC fuses and RFI filter

1. Connect the RFI cable to MK100 on the RFI card.
2. Position the RFI filter in the drive.
3. Fasten 4 M5x11 thread-cutting screws (T20), connecting the RFI filter to the side channels of the drive.

If needed, use the extra M5x11 thread-cutting screws from the kit.

4. Secure 3 M8 nuts (13 mm) at the top of the RFI filter, 1 per phase.
5. Secure the 3 AC fuses by fastening 6 M8 nuts (13 mm), 1 at each end of the fuses.
6. Position the air baffle in the drive, and fasten with 4 screws (T25).

Danfoss A/S
Ulsnaes 1
DK-6300 Graasten
vlt-drives.danfoss.com

.....
Danfoss can accept no responsibility for possible errors in catalogs, brochures, and other printed material. Danfoss reserves the right to alter its products without notice. This also applies to products already on order provided that such alterations can be made without subsequential changes being necessary in specifications already agreed. All trademarks in this material are property of the respective companies. Danfoss and the Danfoss logotype are trademarks of Danfoss A/S. All rights reserved.
.....

