

Thermo switch connection:
 Marked: T1 / T2
 PHOENIX G5/2
 IEC: 0.2-4mm² / 500V
 UL: AWG 28-10 / 300V
 Wire stripping: 8mm (0.31 in)
 Torque: 0.7 Nm (6.2 lb-in)

For temperature switch cable:
 Clamping range: 3.5-7.0 mm (0.14-0.28 in)
 Size Wrench (SW): 16mm (0.63 in)

For resistor cable:
 Cable gland with internal connection for braid
 Clamping Range: 19-28 mm (0.74-1.1 in)
 Size Wrench (SW): 45mm (1.78 in)

PE: M8
 Torque 5-5.5 Nm (44.28-48.71 lb-in)

Resistor connection:
 Marked RB1 / RB2
 ENSTO KE66
 IEC: Cu 2.5-50mm² Al 6-50mm² / 750V
 UL: AWG 6-1/0 / 600V
 Wire stripping: 23mm (0.9 in)
 Torque: 10 Nm (90 lb-in)

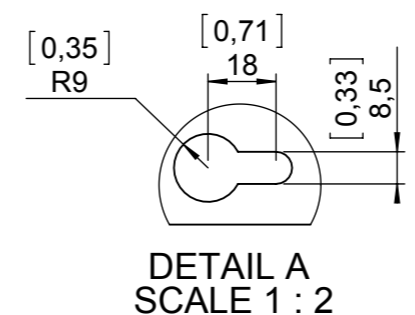

Name plate:
VLT® MCE101 Brake Resistor
www.danfoss.com
 T/C: MCE101xxxxPxxxxE65TAW
 P/N: 175Uxxxx S/N: 456001-443
 xxxR±10% Average power: xxxW
 xxxW/xxxxW@ 10%/40% duty cycle of 30s
 IP65 Tamb.= 40°C xxkg
 175Uxxxx456001-443
 MADE IN DENMARK
 CBT-Vxxx BGHT 930 xxxR KT
 Zxxxxxxx930 Pr.no:123456

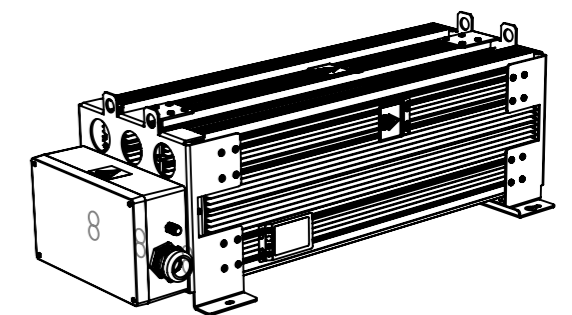

Danfoss code	Typecode	Ohm	L±2 mm	L±0.08 in	L1±2 mm	L1±0.04 in	Weight kg	Center of mass mm		
								X	Y	Z
175U3077	MCE101A5R50P6K30E65TAW	5.5	660	25.98	630	24.80	39	267	164	126
175U3155	MCE101A42R0P8K20E65TAW	42	760	29.92	730	28.74	44.5	332	171	128
175U3163	MCE101A31R0P8K20E65TAW	31	760	29.92	730	28.74	44.5	332	171	128
175U3167	MCE101A28R0P6K30E65TAW	28	660	25.98	630	24.80	39	267	164	126
175U3171	MCE101A22R0P8K20E65TAW	22	760	29.92	730	28.74	44.5	332	171	128
175U3181	MCE101A5R70P8K20E65TAW	5.7	760	29.92	730	28.74	44.5	332	171	128
175U3183	MCE101A3R50P8K20E65TAW	3.5	760	29.92	730	28.74	44.5	332	171	128

Danfoss A/S
 Power Electronics Division
 Ulsnæs 1, 6300 Graasten
 Denmark

MCE 101 Brake Resistor
 xxR ± 10% 930 IP65
 175C0640

Material:
 Path: T:\sw\kute\KUTETEGN\

Weight (g)	Date	Creator:	Approved:	Scale
-	02.02.2012	HEE		1:5
Tolerance:	DS/ISO 2768-cL	File:	930CBT-VxxxBGHT	
No.:	Last Revision:	Rev Date:	By:	Paper size:
2	Name pl. + cent. of mass	11.11.2013	SAPU	A3

Any amendment must be confirmed by DANOTHERM ELECTRIC A/S

Drawing No.:
930CBT-VxxxBGHT

Sheet:
 1 of 1

This drawing is the property of DANOTHERM ELECTRIC A/S and must not be copied without their consent.