

Brochure | iC2-Micro & VLT® Micro Drive FC 51

# Comparison of features and specifications for iC2-Micro and VLT® Micro Drive FC 51



Run reliably at full  
load for ambient  
temperatures up to

**50 °C**



# Contents

General comparison of iC2-Micro and VLT® Micro Drive FC 51 .....	3
Model code and type code comparison .....	4
Product models comparison .....	5
Comparison of dimensions and mounting clearance .....	6
Comparison of terminals.....	8

For your convenience in selecting and retrofitting drives, we provide some key comparative features and specifications of the iC2-Micro and VLT® Micro Drive FC 51. Every attempt has been made to ensure the accuracy of the information.



*iC2-Micro*



*VLT® Micro Drive FC 51*

# General **comparison** of iC2-Micro and VLT® Micro Drive FC 51

## Key specifications

Attribute	iC2-Micro	VLT® Micro Drive FC 51
3-phase 380-480 V	0.37 – 22 kW	0.37 – 22 kW
1-phase 200-240 V	0.37 – 2.2 kW	0.18 – 2.2 kW
3-phase 200-240 V	0.37-3.7 kW <sup>1)</sup>	0.25 – 3.7 kW
1-phase 100-120 V	0.37 - 1.1 kW <sup>1)</sup>	N.A.
Enclosure	IP20/Open type	IP20/Open type
Motor type	IM, PM (SPM & IPM)	Only IM
Motor identification	Automatic Motor Adaptation (AMA)	Automatic Motor Tuning (AMT)
Output frequency	<b>Induction motor</b> <ul style="list-style-type: none"> <li>• 0-200 Hz (VVC+ mode)</li> <li>• 0-500 Hz (U/f mode)</li> </ul> <b>PM motor</b> <ul style="list-style-type: none"> <li>• 0-400 Hz (VVC+ mode)</li> </ul>	<b>Induction motor</b> <ul style="list-style-type: none"> <li>• 0-200 Hz (VVC+ mode)</li> <li>• 0-400 Hz (U/f mode)</li> </ul>
Ramp time	0.01-3600 sec	0.05-3600 sec
Overload capacity	150% for 1 minute	150% for 1 minute
Overload torque at start	200%/1s	N.A.
Maximum motor cable length (unshielded)	75 m (246 ft)	50 m (164 ft)
EMC filter	Two versions: <ul style="list-style-type: none"> <li>• Built-in EMC filter</li> <li>• Without built-in EMC filter</li> </ul>	Built-in EMC filter
Cooling fan	Replacable fan with fan on/off control	Fixed fan without fan control
Ambient temperature	50°C (122°F) at full load Max. 55°C (131°F) with derating	40°C (104°F) at full load Max. 50°C (122°F) with derating
Natural cooling	Up to 0.75 kW (1-phase 200-240 V)	N.A.
HMI	Built-in control panel with potentiometer as default. Control Panel 2.0 OP2 as external control panel option: <ul style="list-style-type: none"> <li>• Multi-language texts display</li> <li>• Easy for commissioning</li> <li>• Parameters setting and copy</li> <li>• Support two kinds of cabinet mounting kit</li> </ul> <input checked="" type="checkbox"/> For control panel details, refer to the Application Guide	Detachable numerical control panel as option: <ul style="list-style-type: none"> <li>• VLT® Control Panel LCP 11 without potentiometer</li> <li>• VLT® Control Panel LCP12 with potentiometer</li> </ul> <input checked="" type="checkbox"/> For control panel details, refer to the Programming Guide
PC tool	MyDrive® Insight	VLT® Motion Control Tool MCT 10
Torque control	Torque open loop control	N.A.
Process controller	PID controller	PI controller
Logical control	Logic/sequence customizer <sup>1)</sup>	Smart Logic Controller (SLC)
RS485 port baud rate	Max. 115,000 baud communication speed	Max. 38,400 baud communication speed
Extra RJ45 port	RS485 based, and used for connecting external control panel and PC tool.	N.A.
Safety standards	EN/IEC 61800-5-1, UL 61800-5-1	EN/IEC 61800-5-1, UL 508C
New features	<ul style="list-style-type: none"> <li>• Kinetic backup</li> <li>• Clockwise direction</li> <li>• Latch start reverse</li> <li>• Input phase loss trip</li> <li>• Setting wizard with application selections</li> <li>• Dead zone control</li> <li>• Sleep mode function <sup>1)</sup></li> </ul>	N.A.

<sup>1)</sup> Upcoming function or feature

# Model code and type code comparison

## iC2-Micro model code definition

1	2	3	4	5	6	7	8	9	10	11	12	13	14	15	16	17	18	19	20	21	22	23	24	25	26	27
i	C	2	-	3	0	F	A	3	N	0	4	-	0	1	A	2	E	2	0	F	4	+	A	C	X	X
								1	N	0	2									F	2		A	C	B	C
																				F	0					

**Product group**  
iC2-30

**Product category**  
FA Frequency converter air cooled

**Product type**  
3N Three phases  
1N Single phase

**Mains voltage**  
04 380-480 V AC  
02 200-240 V AC  
01 100-120 V AC

**\*Current rating**  
\*See current rating on page 5

**Protection rating**  
E20 IP20/Open Type

**EMC category**  
F4 C4 category  
F2 C2 category  
F0 C1 category

**Brake chopper**  
+ACXX None  
+ACBC Integrated

## VLT® Micro Drive FC 51 type code definition

1	2	3	4	5	6	7	8	9	10	11	12	13	14	15	16	17	18	19	20	21	22	23	24	25	26	27
F	C	-	0	5	1	P	K	3	7	T	4	E	2	0	H	3	X	X	C	X	X	X	S	X	X	X
										T	2				H	X	B									
										S	2															

**Product series**  
VLT® Micro Drive FC51

**\*Power size**  
\*See power rating on page 5

**Mains voltage**  
S2 Single phase 200-240 V AC  
T2 Three phases 200-240 V AC  
T4 Three phases 380-480 V AC

**Protection rating**  
E20 IP20/Chassis

**RFI filter**  
H3 RFI Class A1/B  
HX No RFI filter

**Hardware, coating**  
C Coated PCB

**Hardware display**  
X No display  
B Brake chopper

**Hardware, mains option**  
X No mains option

**Hardware, adaption A**  
X No adaption

**Hardware, adaption B**  
X No adaption

**SXXX Standard SW**

**Brake chopper**  
X No brake chopper  
B Brake chopper

# Product models comparison

## Voltage 1 x 100-120 V AC <sup>1)</sup>

Power rating [kW/hp]	Current rating [A]	iC2-Micro				VLT® Micro Drive FC 51			
		Model code	Enclosure	EMC level	Brake chopper	Type code	Enclosure	EMC level	Brake chopper
0.37/0.5	2.4	iC2-30FA1N01-02A4E20F4+ACXX	MA01c	C4	No	N.A.			
1.1/1.5	4.8	iC2-30FA1N01-04A8E20F4+ACXX	MA02c	C4	No	N.A.			

## Voltage 1 x 200-240 V AC

Power rating [kW/hp]	Current rating [A]	iC2-Micro				VLT® Micro Drive FC 51			
		Model code	Enclosure	EMC level	Brake chopper	Type code	Enclosure	EMC level	Brake chopper
0.18/0.24	1.2	N.A.				FC-51PK18S2E20H3XXCXXXSXXX	M1	C1	No
0.37/0.5	2.2	iC2-30FA1N02-02A2E20F0+ACXX iC2-30FA1N02-02A2E20F4+ACXX	MA01c	C1 & C4	No	FC-51PK37S2E20H3XXCXXXSXXX	M1	C1	No
0.75/1.0	4.2	iC2-30FA1N02-04A2E20F0+ACXX iC2-30FA1N02-04A2E20F4+ACXX	MA01c	C1 & C4	No	FC-51PK75S2E20H3XXCXXXSXXX	M1	C1	No
1.5/2.0	6.8	iC2-30FA1N02-06A8E20F0+ACXX iC2-30FA1N02-06A8E20F4+ACXX	MA02c	C1 & C4	No	FC-51P1K5S2E20H3BXCXXXSXXX	M2	C1	No
2.2/3.0	9.6	iC2-30FA1N02-09A6E20F0+ACXX iC2-30FA1N02-09A6E20F4+ACXX	MA02a	C1 & C4	No	FC-51P2K2S2E20H3BXCXXXSXXX	M3	C1	No

## Voltage 3 x 200-240 V AC <sup>1)</sup>

Power rating [kW/hp]	Current rating [A]	iC2-Micro				VLT® Micro Drive FC 51			
		Model code	Enclosure	EMC level	Brake chopper	Type code	Enclosure	EMC level	Brake chopper
0.18/0.24	1.2	N.A.				FC-51PK25T2E20H3XXCXXXSXXX	M1	C2	No
0.37/0.5	2.4	iC2-30FA3N02-02A4E20F4+ACXX	MA01a	C4	No	FC-51PK37T2E20H3XXCXXXSXXX	M1	C2	No
0.75/1.0	4.2	iC2-30FA3N02-04A4E20F4+ACXX	MA01a	C4	No	FC-51PK75T2E20H3XXCXXXSXXX	M1	C2	No
1.5/2.0	7.8	iC2-30FA3N02-07A8E20F4+ACBC	MA02a	C4	Yes	FC-51P1K5T2E20H3BXCXXXSXXX	M2	C2	No
2.2/3.0	11	iC2-30FA3N02-11A8E20F4+ACBC	MA03a	C4	Yes	FC-51P2K2T2E20H3BXCXXXSXXX	M3	C2	No
3.7/5.0	15.2	iC2-30FA3N02-15A8E20F4+ACBC	MA03a	C4	Yes	FC-51P3K7T2E20H3BXCXXXSXXX	M3	C2	No

## Voltage 3 x 380-480 V AC

Power rating [kW/hp]	Current rating [A]	iC2-Micro				VLT® Micro Drive FC 51			
		Model code	Enclosure	EMC level	Brake chopper	Type code	Enclosure	EMC level	Brake chopper
0.37/0.5	1.2	iC2-30FA3N04-01A2E20F2+ACXX iC2-30FA3N04-01A2E20F4+ACXX	MA01a	C2 & C4	No	FC-51PK37T4E20H3XXCXXXSXXX	M1	C2	No
0.75/1.0	2.2	iC2-30FA3N04-02A2E20F2+ACXX iC2-30FA3N04-02A2E20F4+ACXX	MA01a	C2 & C4	No	FC-51PK75T4E20H3XXCXXXSXXX	M1	C2	No
1.5/2.0	3.7	iC2-30FA3N04-03A7E20F2+ACXX iC2-30FA3N04-03A7E20F4+ACXX	MA01a	C2 & C4	No	FC-51P1K5T4E20H3BXCXXXSXXX	M2	C2	Yes
2.2/3.0	5.3	iC2-30FA3N04-05A3E20F2+ACBC iC2-30FA3N04-05A3E20F4+ACBC	MA02a	C2 & C4	Yes	FC-51P2K2T4E20H3BXCXXXSXXX	M2	C2	Yes
3.0/4.0	7.2	iC2-30FA3N04-07A2E20F2+ACBC iC2-30FA3N04-07A2E20F4+ACBC	MA02a	C2 & C4	Yes	FC-51P3K0T4E20H3BXCXXXSXXX	M3	C2	Yes
4.0/5.5	9.0	iC2-30FA3N04-09A0E20F2+ACBC iC2-30FA3N04-09A0E20F4+ACBC	MA02a	C2 & C4	Yes	FC-51P4K0T4E20H3BXCXXXSXXX	M3	C2	Yes
5.5/7.5	12.0	iC2-30FA3N04-12A0E20F2+ACBC iC2-30FA3N04-12A0E20F4+ACBC	MA03a	C2 & C4	Yes	FC-51P5K5T4E20H3BXCXXXSXXX	M3	C2	Yes
7.5/10	15.5	iC2-30FA3N04-15A5E20F2+ACBC iC2-30FA3N04-15A5E20F4+ACBC	MA03a	C2 & C4	Yes	FC-51P7K5T4E20H3BXCXXXSXXX	M3	C2	Yes
11/15	23.0	iC2-30FA3N04-23A0E20F2+ACBC iC2-30FA3N04-23A0E20F4+ACBC	MA04a	C2 & C4	Yes	FC-51P11KT4E20H3BXCXXXSXXX	M4	C2	Yes
15/20	31.0	iC2-30FA3N04-31A0E20F2+ACBC iC2-30FA3N04-31A0E20F4+ACBC	MA04a	C2 & C4	Yes	FC-51P15KT4E20H3BXCXXXSXXX	M4	C2	Yes
18.5/25	37.0	iC2-30FA3N04-37A0E20F2+ACBC iC2-30FA3N04-37A0E20F4+ACBC	MA05a <sup>1)</sup>	C2 & C4	Yes	FC-51P18KT4E20H3BXCXXXSXXX	M5	C2	Yes
22/30	43.0	iC2-30FA3N04-43A0E20F2+ACBC iC2-30FA3N04-43A0E20F4+ACBC		C2 & C4	Yes	FC-51P22KT4E20H3BXCXXXSXXX	M5	C2	Yes

<sup>1)</sup> Available 2024

# Comparison of **dimensions** and **mounting clearance**

Voltage type	Power rating [kW/hp]	iC2-Micro						VLT® Micro Drive FC 51					
		Height [H]	Width [W]	Depth [D]	Height [H1]	Width [W2]	Weight [kg]	Height [H]	Width [W]	Depth [D]	Height [H1]	Width [W2]	Weight [kg]
1 x 100 V		MA01c						N.A.					
	0.37/0.5	150 (5.9)	70 (2.8)	143 (5.6)	140.4 (5.5)	55 (2.2)	1.0						
1 x 220 V		MA02c						M1					
	1.1/1.5	176 (6.9)	75 (3.0)	164 (6.5)	150 (5.9)	59 (2.3)	1.3						
1 x 220 V	0.18/0.24	N.A.						150 (5.9)	70 (2.8)	148 (5.8)	140.4 (5.5)	55 (2.2)	1.1
		MA01c						M1					
	0.37/0.5	150 (5.9)	70 (2.8)	143 (5.6)	140.4 (5.5)	55 (2.2)	1.0	150 (5.9)	70 (2.8)	148 (5.8)	140.4 (5.5)	55 (2.2)	1.1
	0.75/1.0	MA02c						M2					
	1.5/2.0	176 (6.9)	75 (3.0)	164 (6.5)	150 (5.9)	59 (2.3)	1.3	176 (6.9)	75 (3.0)	168 (6.6)	166.4 (6.6)	59 (2.3)	1.6
		MA02a						M3					
	2.2/3.0	186 (7.3)	75 (3.0)	175 (7.0)	176 (6.9)	59 (2.3)	1.6	239 (9.4)	90 (3.5)	194 (7.6)	226 (8.9)	69 (2.7)	3
3 x 220 V		MA01						M1					
	0.18/0.24	N.A.						1.1					
	0.37/0.5	150 (5.9)	70 (2.8)	158 (6.2)	140.4 (5.5)	55 (2.2)	1.1						
	0.75/1.0	MA02a						M2					
	1.5/2.0	186 (7.3)	75 (3.0)	175 (7.0)	176 (6.9)	59 (2.3)	1.6	176 (6.9)	75 (3.0)	168 (6.6)	166.4 (6.6)	59 (2.3)	1.6
		MA02a						M3					
	2.2/3.0	238.5 (9.4)	90 (3.5)	200 (7.9)	291 (11.5)	69 (2.7)	3.0	239 (9.4)	90 (3.5)	194 (7.6)	226 (8.9)	69 (2.7)	3.0
3 x 400 V		MA01a						M1					
	0.37/0.5	150 (5.9)	70 (2.8)	158 (6.2)	140.4 (5.5)	55 (2.2)	1.1	150 (5.9)	70 (2.8)	148 (5.8)	140.4 (5.5)	55 (2.2)	1.1
	0.75/1.0	MA01a						M2					
	1.5/2.0	150 (5.9)	70 (2.8)	158 (6.2)	140.4 (5.5)	55 (2.2)	1.1	176 (6.9)	75 (3.0)	168 (6.6)	166.4 (6.6)	59 (2.3)	1.6
		MA02a						M2					
	2.2/3.0	186 (7.3)	75 (3.0)	175 (7.0)	176 (6.9)	59 (2.3)	1.6	176 (6.9)	75 (3.0)	168 (6.6)	166.4 (6.6)	59 (2.3)	1.6
		MA02a						M3					
	3.0/4.0	186 (7.3)	75 (3.0)	175 (7.0)	176 (6.9)	59 (2.3)	1.6	239 (9.4)	90 (3.5)	194 (7.6)	226 (8.9)	69 (2.7)	3.0
	4.0/5.5	MA03a						M3					
	5.5/7.5	238.5 (9.4)	90 (3.5)	200 (7.9)	291 (11.5)	69 (2.7)	3.0	239 (9.4)	90 (3.5)	194 (7.6)	226 (8.9)	69 (2.7)	3.0
7.5/10	MA04a						M4						
11/15	292 (11.5)	125 (4.9)	244.5 (9.6)	365.5 (14.4)	97 (3.8)	6.0	292 (11.5)	125 (5.0)	241 (9.5)	272.4 (10.7)	97 (3.8)	6.0	
15/20	MA05a						M5						
18.5/25	Not released						335 (13.2)	165 (6.5)	140 (5.5)	315 (12.4)	140 (5.5)	9.5	
22/30													

H = Height [mm (in)], W = Width [mm (in)], D = Depth [mm (in)], H1 = Height [mm (in)], W1 = Width [mm (in)]

## Note

- H, W and D are for overall dimensions
- H1 and W1 are for mounting hole dimensions
- The potentiometer on the local control panel extends 6.5 mm (0.26 in) from the drive.

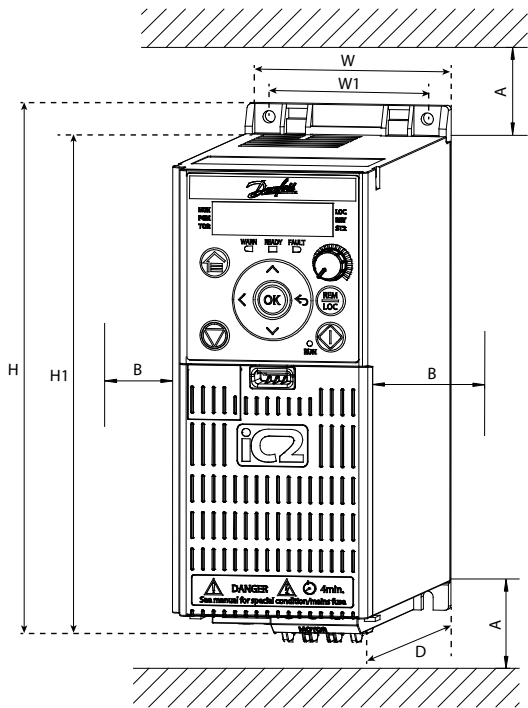

**iC2-Micro**

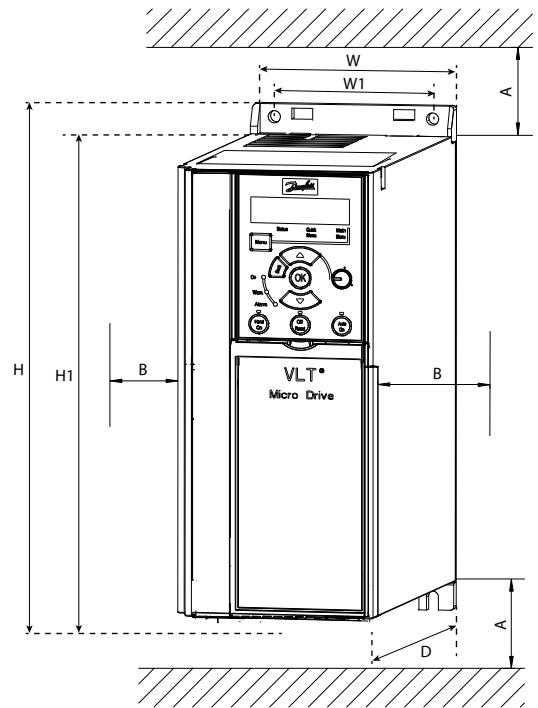

**VLT® Micro Drive FC 51**



### Mounting clearance

		iC2-Micro		VLT® Micro Drive FC 51	
Direction	Frame designation	Minimum cooling clearances		Enclosure size	Minimum cooling clearances
Above and below (A)	All frame designations	100 mm (3.9 in) for 50°C (122°F)		All enclosure sizes	100 mm (3.9 in) for 40°C (104°F)
Sides (B)	MA01a to MA05a, MA02c	0 mm (0 in) for 50°C (122°F)		All enclosure sizes	0 mm (0 in) for 40°C (104°F)
	MA01c (natural cooling)	0 mm (0 in) for 40°C (104°F) 10 mm (0,39 in) and above for 50°C (122°F)			

# Comparison of terminals

## Terminals

Attribute	iC2-Micro		VLT® Micro Drive FC 51	
Terminal type	Spring type		Screw type	
I/O terminals	Terminal number	Type	Terminal number	Type
	T12	24V	T12	24V
	T13	DI1	T18	DI1
	T14	DI2	T19	DI2
	T15	DIO	T20	GND
	T17	DI3	T27	DI3
	T18	DI4	T29	DI4
	T20	GND	T33	DI5
	T31	AO1	T42	AO1
	T32	10V	T50	10V
	T33	AI1	T53	AI1
	T34	AI2	T55	GND
	T35	GND	T60	AI2
	01, 02, 03	Relay	01, 02, 03	Relay
Digital output	Programmable T15 could be set as digital output. Max. output current is 40 mA		Programmable T42 could be set as digital output. Max. output current is 20 mA	
Pulse input	Programmable T18 can be set as pulse input (4-32 kHz)		Programmable T33 can be set as pulse input (20-5000 Hz)	
Pulse output	Programmable T15 can be set as pulse output (4-32 kHz)		N.A.	
Analog inputs mode switch	By software paramter		By hardware switch	
PNP & NPN switch	By software paramter		By hardware switch	
Illustration				

## How to order

To order, go to [store.danfoss.com](https://store.danfoss.com) and choose country/region.