



# BACKPLANE ASSY

100021-1 & 100021-2.

 <p><b>Installation and servicing of Danfoss Turbocor® compressors by qualified and product trained personnel only. Follow these instructions and sound refrigeration/electrical/servicing practices relating to installation, commissioning, maintenance, and service.</b></p>			
<p>Consult the appropriate Danfoss Turbocor Compressors Inc. (DTC) Service Manual on <a href="http://turbocor.danfoss.com">turbocor.danfoss.com</a> for detailed service instructions.</p>	<p><b>Never power compressor without covers in place and secured.</b></p> <p><b>Removing the mains input cover will expose you to a voltage hazard of up to 575V. Ensure the mains input power is off and locked out before removing cover.</b></p> <p><b>Before removing top cover, wait at least 20 minutes after isolating AC power to allow the high voltage capacitors to discharge.</b></p>	<p>Always wear appropriately rated safety equipment when working around equipment and/or components energized with high voltage.</p> <p><b>This equipment contains hazardous voltages that can cause serious injury or death.</b></p>	<p><b>Recover all refrigerant from compressor in accordance with local codes and ensure pressure is fully vented before the removal of refrigerant containing components.</b></p>

1 - Introduction:

BACKPLANE ASSY replacement.

This kit contains the Backplane Assembly and the associated hardware. Please refer to our Service Manual for details regarding the replacement of the Backplane.

**NOTE:** Danfoss LLC has a new vendor that supplies an updated version of the Backplane. The new version, 100021-2, has been upgraded for future compressor enhancements. This new Backplane may be included as a replacement for Kit 100021-1 if there is no availability at the time of the order. Both versions of this Backplane are fully compatible with all current and former compressor versions and the installation steps are identical.

We have made the **TTS/TGS/TTH/TGH Service Manual** available to anyone. To access the manual, you may scan the applicable QR code below or you may go to our DTC website at [www.turbocoroem.com](http://www.turbocoroem.com). At the top of the page there is a pull-down menu called "Quick Links." Click this menu and select the appropriate service manual.

Refer to the applicable QR code below to download the TTS/TGS/TTH/TGH Service Manual.

**English**



**Chinese**



---

## 2 - BACKPLANE ASSY Removal Instructions:

1. Isolate compressor power as described in Section "Electrical Isolation of the Compressor" of the Service Manual (M-SV-001).
2. Remove the Service Side Cover.
3. Remove the Serial Driver.
4. Remove the BMCC.
5. Remove the PWM.

**NOTE:** Do NOT disconnect the bearing feed cables from the feed throughs.

6. Disconnect and remove all connectors from the Backplane, including earth lead under the right-hand top of the Backplane circuit board.
7. Remove the three (3) fasteners that secure the Backplane assembly to the compressor housing. Refer to Figure 1 (Backplane Fasteners). Do NOT remove the fastener from center bottom or top left of the Backplane circuit board.

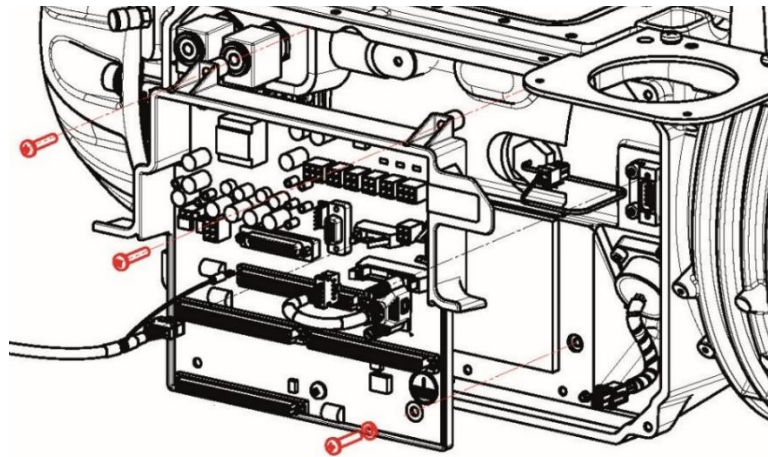

Figure 1– Backplane Fasteners

8. Remove the Backplane Assembly.

---

## 3 - BACKPLANE ASSY Installation Instructions:

1. Position the plastic stand-offs to the main compressor housing and loosely install the Backplane housing fasteners.
2. Install Backplane grounding fastener in lower R/H corner of the Backplane circuit board. Install a metal (not plastic) washer under the head of the fastener. Tighten the remaining fasteners.
3. Attach the grounding ring terminal from the Inverter interface cable to the fastener at the upper right corner of the Backplane and torque to 3 Nm (27 in.lb.).
4. Reconnect all cables to the Backplane.

**NOTE:** To reinstall the Backplane, make sure that inputs are connected to the proper connectors. Verify printed codes on the plugs (harness side) with the corresponding receptacles on the Backplane.

5. Install the PWM.

**NOTE:** Verify there is sufficient thermal paste present between the PWM and compressor housing.



6. Install the BMCC.
7. Install the Serial Driver.

8. Install the Service Side Cover.
9. Return the compressor to normal operation.

---

4 - Kit Contents:

---

QTY	Part(s) Description	Picture(s)
1	BACKPLANE ASSEMBLY	
3	SCREW, M5x25 TORX PAN HEAD - 902885	
1	WASHER, M5, FLAT - 902803	

---

5 - List of Changes

---

Revision	Date	Description of Change
N	8/26/2022	Kit number 100021 was removed from the top of this instruction and 100021-2 was added. 100021 – No longer used and replaced by kits 100021-1 and 100021-2