

**VACON<sup>®</sup> NXP**  
AC DRIVES

**FUNCTIONAL SAFETY FOR LIFTS  
APPLICATION GUIDE**

**VACON<sup>®</sup>**



## TABLE OF CONTENTS

Document code: DPD02141B  
Revision release date: 11/1/2019

1.	<b>About this manual</b> .....	<b>4</b>
2.	<b>Safety</b> .....	<b>5</b>
2.1	The safety symbols used in the manual.....	5
3.	<b>General information</b> .....	<b>6</b>
3.1	Lift standard.....	6
3.2	Requirements.....	6
3.3	Achieved safety levels.....	6
3.4	References.....	7
3.5	Abbreviations.....	7
4.	<b>Installation requirements</b> .....	<b>8</b>
4.1	Installation and wiring of the OPT-AF option board.....	8
4.2	Activation / deactivation of ATEX thermistor function.....	9
5.	<b>STO connection in VACON® NXP AC drive</b> .....	<b>10</b>
5.1	Differential voltage cabling requirements.....	11
5.2	Non-differential voltage cabling requirements.....	12
6.	<b>STO monitoring</b> .....	<b>13</b>
6.1	Monitoring menu "M7 Expander Boards".....	13
7.	<b>STO maintenance</b> .....	<b>13</b>
8.	<b>STO parametrization of VACON® NXP AC drive</b> .....	<b>13</b>

## 1. ABOUT THIS MANUAL

This manual is copyright of Vacon Ltd. All Rights Reserved. The manual is subject to change without prior notice. The original language of these instructions is English.

In this manual you can read about the use of VACON® NXP AC drive SIL3 STO function in lift applications according to EN81-20/50:2015.

The SIL3 STO function is not application dependent. Thus, this manual applies to all lift applications in VACON® NXP products regardless of the application version.

Table 1. Version of the manual

Date	Revision	Updates
01/28/2019	A	The first published version of this manual
10/29/2019	B	<p>Date correction for the Standard EN81-20:2014 (Pag.6, 13)</p> <p>Correction of digit number in reference valid for OPT-AF (Pag.6)</p> <p>Added specification to work in environments with Pollution Degree higher than 1 or 2. (Pag.8)</p> <p>Bolded and red characters for text “<b>Fault F8 Subcode 8</b>” (Pag.10, 13)</p>



## 2. SAFETY

### 2.1 THE SAFETY SYMBOLS USED IN THE MANUAL

This manual contains warnings and cautions, which are identified with safety symbols. The warnings and cautions give important information on how to prevent injury and damage to the equipment or your system.

Read the warnings and cautions carefully and obey their instructions.

Table 2. The safety symbols

The safety symbol	The safety word	Description
	WARNING!	If you do not obey the instructions, injury or death is possible.
	CAUTION!	If you do not obey the instructions, damage to the equipment is possible.
	HOT SURFACE!	If you do not obey the instructions, burns are possible.

**NOTE!** You can download the English and French product manuals with applicable safety, warning and caution information from <https://www.danfoss.com/en/service-and-support/>.

**REMARQUE** Vous pouvez télécharger les versions anglaise et française des manuels produit contenant l'ensemble des informations de sécurité, avertissements et mises en garde applicables sur le site <https://www.danfoss.com/en/service-and-support/>.

### 3. GENERAL INFORMATION

#### 3.1 LIFT STANDARD

The EN81-20/50:2014 standard for lift installations came into force on September 1<sup>st</sup>, 2017.

The lift standard allows the use of adjustable speed electric power drive STO function for removal of power from the motor. The STO function can replace the commonly used solution with two contactors between the motor and the AC drive, according to EN81-20:2014 clauses 5.9.2.5.4 d) and 5.9.3.4.2 d).

#### EN81-20:2014 5.9.2.5.4 d)

“An adjustable speed electrical power drive system with a safe torque off (STO) function according to EN61800-5-2:2007, 4.2.2.2 fulfilling SIL3 requirements, with a hardware fault tolerance of at least 1.”

#### EN81-20:2014 5.9.3.4.2 d)

“The electric motor shall be stopped by an adjustable speed electrical power drive system with a safe torque off (STO) function according to EN 61800-5-2:2008, 4.2.2.2 fulfilling SIL3 requirements with a hardware fault tolerance of at least 1.”

By using VACON® NXP AC drive together with the OPT-AF STO option board, the lift standard clauses are fulfilled with the aim to use a system without motor contactors.

#### 3.2 REQUIREMENTS

Table 3. Required hardware and software

Component	Version	Comment
Control board	Hardware: VB00761G or newer Software: NXP00002V197 or newer	
STO option board (OPT-AF)	Hardware: VB00328E or newer	

#### 3.3 ACHIEVED SAFETY LEVELS

The STO function in VACON® NXP AC drive with hardware and software listed in Table 3. fulfills:

- SIL 3, HFT = 1 according to EN/IEC 61800-5-2 and IEC 61508
- PL e, cat. 3 according to EN ISO 13849-1

By fulfilling SIL 3 and HFT = 1 for the STO function, VACON® NXP AC drive is ready to work without motor contactors in the lift installation, interrupting safely the motor current, and consequently no motor torque can be applied.

**NOTE!** Achieved safety levels can be seen from the VACON® NXP AC drive parameter M.7.2.2.1.

**CAUTION!**

*The OPT-AF option board and its safety functions do not electrically isolate the drive output from the mains supply. If electrical work is to be carried out on the AC drive, the motor or the motor cabling, the AC drive must be completely isolated from the mains supply, e.g. using an external supply disconnecting switch. For example, see EN 60204-1 section 5.3.*

**3.4 REFERENCES**

## Manuals

- VACON® NX OPT-AF Safe Torque Off & ATEX option board user manual

## Standards

- EN 61800-5-1(2007) – Adjustable speed electrical power drive systems – Part 5-1: Safety requirement – Electrical, thermal and energy
- EN 61800-5-2(2016) – Adjustable speed electrical power drive systems – Part 5-2: Safety requirement – Functional
- EN 81-20 (2014) – Safety rules for the construction and installation of lifts – Lifts for the transport of persons and goods – Part 20: Passenger and goods passenger lifts
- EN 81-50 (2014) – Safety rules for the construction and installation of lifts – Examinations and tests. Part 50: Design rules, calculations, examinations and tests of lift components

## Certificates

- SIL3 STO certificate, see VACON® NX OPT-AF Safe Torque Off & ATEX option board user manual

**3.5 ABBREVIATIONS**

Term or abbreviation	Description
HFT	Hardware Fault Tolerance. The number of hardware failures that the safety system can tolerate without the loss of the safety function.
PDS	Power Drive System. According to 61800-5-1.
PL	Performance level according to EN13849
SIL	Safety integrity level according to EN61800-5-2
STO	Safe Torque Off. Safety function according to EN61800-5-2.

## 4. INSTALLATION REQUIREMENTS

Electrical and electronic circuits of VACON® NXP AC drive have been designed according to Pollution degree 2 and overvoltage category III requirements according to 61800-5-1. Therefore to fulfill the required safety requirements (electrical and functional), VACON® NXP AC drive must be installed inside an area of Pollution degree 2.

Table 4. Pollution degree definitions according to 61800-5-1 (2007)

Pollution degree	Description
1	No pollution or only dry, non-conductive pollution occurs. The pollution has no influence.
2	Normally, only non-conductive pollution occurs. Occasionally, however, temporary conductivity caused by condensation is to be expected, when the PDS is out of operation.
3	Conductive pollution or dry non-conductive pollution occurs, which becomes conductive due to condensation, which is to be expected.
4	The pollution generates persistent conductivity caused, for example, by conductive dust, rain or snow.

**NOTE!** If the installation environment is not according to Pollution degree 1 or 2, a cabinet providing protection against pollution must be used (for example an IP54 drive cabinet). Functional Safety requirements can be fulfilled also by using coated PCB's.

### 4.1 INSTALLATION AND WIRING OF THE OPT-AF OPTION BOARD

The OPT-AF option board provides VACON® NXP products with the Safe Torque Off (STO) safety function. The option board also features an ATEX thermistor input for protection against motor overtemperature, where the controlled motor is located in an ATEX environment. Two free programmable relay outputs are also available in the option board.

STO input  
 ATEX thermistor input  
 1 NO relay output  
 1 NO/NC relay output  
 Slot: B

For more details, see VACON® NX OPT-AF Safe Torque Off & ATEX option board user manual on [www.danfoss.com](http://www.danfoss.com) website.



4.2 ACTIVATION / DEACTIVATION OF ATEX THERMISTOR FUNCTION

If motor thermistor is used in the lift installation:

- See VACON® NX OPT-AF Safe Torque Off & ATEX option board user manual on [www.danfoss.com](http://www.danfoss.com) website.
- Connect to the input terminal (orange).
- Set the jumper X10 to ON position.

If motor thermistor is not used in the lift installation, the supervision in board needs to be disabled:

- Make short circuit to the input terminals (orange).
- Set the jumper X10 “thermistor short circuit supervision” jumper to OFF position.

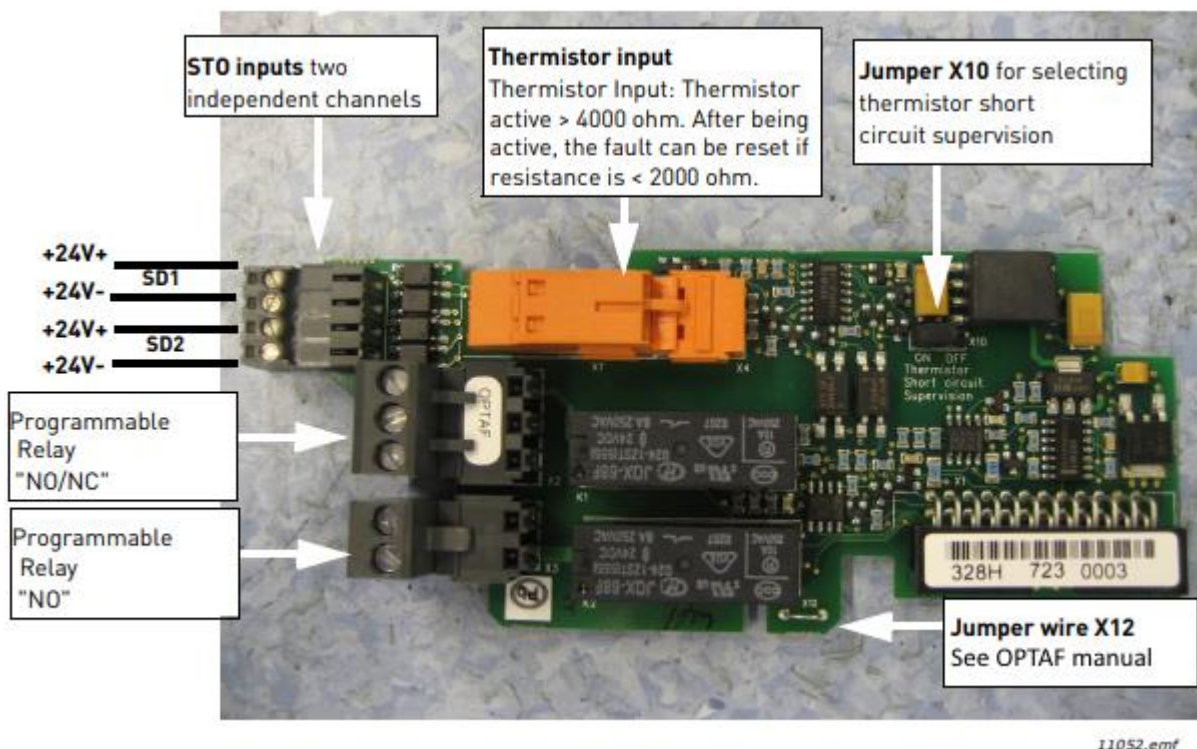

Figure 1. The OPTAF option board

## 5. STO CONNECTION IN VACON® NXP AC DRIVE

VACON® NXP AC drive has two independent STO channels with potential free reference.

Table 5. OPT-AF I/O terminals

Terminal	Signal name	Technical information
1	SD1+	Isolated STO input +24 V (+/-20%, 10–15 mA)
2	SD1-	Virtual GND 1
3	SD2+	Isolated STO input +24V (+/-20%, 10–15 mA)
4	SD2-	Virtual GND 2

Two independent relays must be used to connect to the STO channels. The relays do not need be safety relays or guided contact relays, because VACON® NXP AC drive monitors the states of the STO inputs (STO inputs must be in the same state). The relays can be standard relays, fulfilling the product standard for relays EN 61810-1. The signals to the STO channels must be provided by safety circuit or safety change.

Table 6. VACON® NXP OPT-AF option board monitoring function

$V_{SD1+} - V_{SD1-}$	$V_{SD2+} - V_{SD2-}$	Drive Status
0 VDC	0 VDC	STO active
24 VDC	0 VDC	STO diagnostic fault (F8, S30)
0 VDC	24 VDC	STO diagnostic fault (F8, S30)
24 VDC	24 VDC	Ready to run

If one or both channels are inactive, VACON® NXP AC drive is not modulating and will not provide current to the motor. It is important to know that if STO activation happens while the motor is running, modulation stops by coasting without any ramp. Therefore the brake has to be closed at the same time to avoid overaccelerations of the lift car.

If the STO channels are in different statuses for more than 5 seconds, safe monitoring is activated and the blocking **Fault F8 Subcode 30** is tripped. This fault cannot be reset from the keypad or PC. The AC drive needs to be powered off to reset the fault.

### 5.1 DIFFERENTIAL VOLTAGE CABLING REQUIREMENTS

If both STO channels are referenced to different voltages, cables do not need to be independent shielded cables or installed in different electrical conductors inside different conduits. This is due to VACON® NXP AC drive diagnostics.

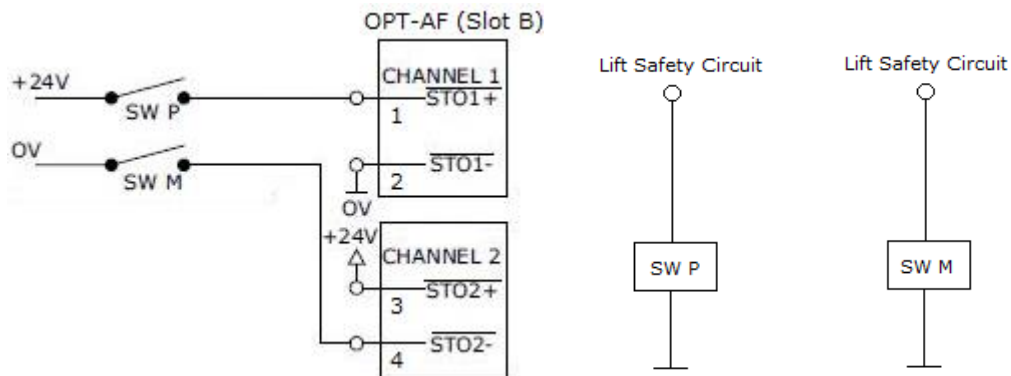

**SW P = Relay in safety circuit 1**

- No independent shielded cables needed
- No different conductors inside different conduits need

*Figure 2. Differential voltage cabling*

**NOTE!** If the cable used is not shielded, the basics for EMC immunity must be considered.

The STO signals handled by the relays' auxiliary contacts are 0 V and 24 Vdc. The voltages for relay contacts can be external or auxiliary supply from VACON® NXP AC drive. For example, from OPTA1 terminals 12 (+24 VDC) and 13 (GND).

## 5.2 NON-DIFFERENTIAL VOLTAGE CABLING REQUIREMENTS

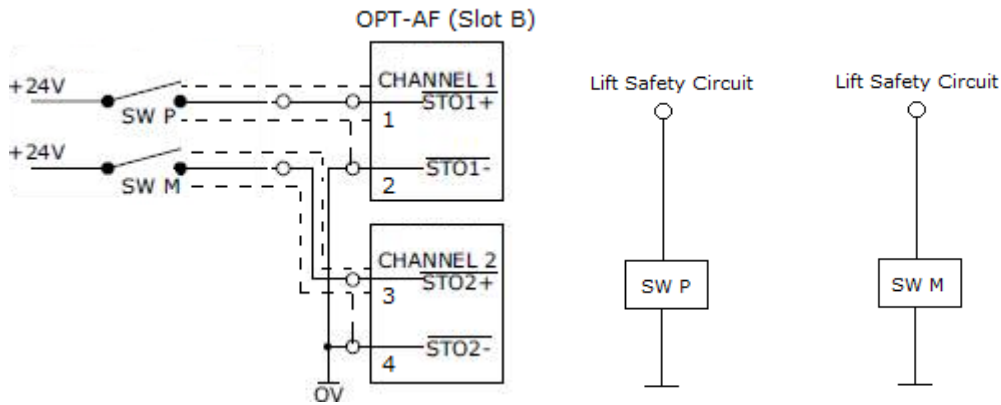

**SW P = Relay in safety circuit 1**

*Figure 3. Non-differential voltage cabling*

With this connection it is not possible to work without a shielded cable, because short-circuit failures cannot be detected by the diagnostic function of the VACON® NXP OPT-AF option board.

For proper installation:

- Independent shielded cables are needed (shield connected to 0 V)

OR

- Different conductors inside different conduits are needed (armor connected to 0 V)

## 6. STO MONITORING

VACON® NXP AC drive continuously internally monitors the STO inputs against hardware faults, thus fulfilling clause 5.11.2.3 of the EN81-20:2014 standard. Therefore, it is not mandatory to monitor the STO status by the lift controller.

If needed, VACON® NXP AC drive can send the STO status through a digital output, relay output or fieldbus to the lift controller for diagnostic or monitoring purposes.

If the STO channels are in different statuses for more than 5 seconds, safe monitoring is activated and the blocking **Fault F8 Subcode 30** is tripped. This fault cannot be reset from the keypad or PC. The AC drive needs to be powered off to reset the fault.

### 6.1 MONITORING MENU “M7 EXPANDER BOARDS”

Monitor V7.2.2 “Safety Levels” shows the safety level (SIL2 or SIL3) detected by the AC drive.

Parameter group G2.7.2.2.1 I/O Monitor OPT-AF shows the statuses of the digital inputs and outputs of the OPT-AF option board.

## 7. STO MAINTENANCE

VACON® NXP AC drive continuously internally monitors the STO inputs against hardware faults, and the VACON® NXP AC drive STO function does not need periodical tests.

**NOTE!** Local legislation/standards or external components (e.g. relays) used to control the STO inputs may require periodical testing.

## 8. STO PARAMETRIZATION OF VACON® NXP AC DRIVE

There is no need to change any parameters in the lift application for it to work with the STO function.

The following parameters must be set from the M7 “Expander Boards” parameters:

- P2.7.2.1.1 “Therm Trip (HW) = OFF/ON. Depending on whether the motor thermistor is used in the installation. Also related to P7.2.1.2.
- P2.7.2.1.2 “Start Up Prev” = No action.

# VACON<sup>®</sup>

[www.danfoss.com](http://www.danfoss.com)

Vacon Ltd  
Member of the Danfoss Group  
Runsorintie 7  
65380 Vaasa  
Finland

Document ID:



DPD02141B

Rev. B