

VACON[®] NX
AC DRIVES

**ACTIVE FRONT END (AFE)
ARFIFF02
APPLICATION MANUAL**

VACON[®]

TABLE OF CONTENTS

Document: DPD000905B

Software code: ARFIFF02V148

Release date : 21/2/17

1.	Introduction	3
2.	AFE units.....	4
2.1	500 Vac units Air Cooled	4
2.2	690 Vac units Air Cooled	5
2.3	500 Vac units Liquid-Cooled	6
2.4	690 Vac units Liquid-Cooled	7
3.	Operation	8
3.1	Main contactor control.....	8
3.2	Quick Start instructions	9
4.	CONTROL IO	12
5.	AFE Application - Monitoring values	14
5.1	Monitoring values.....	15
5.1.1	Monitoring 1	15
5.1.2	Monitoring values 2.....	16
5.1.3	FieldBus Monitoring values	16
5.1.4	IO Monitoring values	16
5.1.5	Unit Monitoring Values.....	17
5.1.6	Monitoring 1 values.....	17
5.1.7	Monitoring 2 values.....	19
5.1.8	Fieldbus monitoring values	19
5.1.9	IO Monitoring values	27
5.1.10	Unit Monitoring values	28
6.	AFE Application - Parameter lists.....	29
6.1	Basic parameters.....	30
6.2	Reference Handling	31
6.3	Input signals.....	32
6.3.1	Digital inputs	32
6.3.2	Analogue inputs	33
6.4	Output signals	34
6.4.1	Digital Outputs	34
6.4.2	Analogue Output 1.....	35
6.5	Limit Settings	36
6.5.1	Current Limit.....	36
6.5.2	Power Limit	36
6.5.3	Auto Start Stop	36
6.5.4	DC Voltage	36
6.6	Drive Control parameters	37
6.7	Control parameters	38
6.8	Fieldbus parameters.....	39
6.9	Protections	40
6.9.1	General.....	40
6.9.2	PT-100	41
6.9.3	Earth fault	41
6.9.4	Fieldbus.....	41
6.10	Auto reset parameters.....	42
6.11	DIN ID Control	42
6.12	Keypad control	42
6.13	System menu	42
6.14	Expander boards	42

7.	Description of parameters	43
7.1	Basic parameters	43
7.2	Reference Handling	44
7.3	Input signals	46
7.3.1	Digital inputs	46
7.3.2	Analogue Inputs	49
7.4	Output signals	50
7.4.1	Digital outputs	50
7.4.2	Analogue outputs	50
7.5	Limit settings	52
7.5.1	Current Limits	52
7.5.2	Power Limits	52
7.5.3	Auto Start Stop function	52
7.5.4	DC Voltage limit parameters	53
7.6	Drive control	54
7.6.1	Drive control	56
7.7	Fieldbus parameters	58
7.8	Protections	59
7.8.1	PT100 Temperature	60
7.8.2	Earth fault	61
7.8.3	Fieldbus	62
7.9	Auto restart	63
7.10	DIN ID Control	64
7.11	Keypad control	64
8.	Fieldbus Profile for VACON® Regenerative Drive	65
8.1	Signals from Overriding System to VACON® regenerative Drive	65
8.2	Signals from VACON® Drive to Overriding system	65
8.3	Main Control Word	66
8.4	FB Reference Control	67
8.5	Main Control Word (in DeviceNet)	68
8.6	Main Status Word	70
8.7	Fault Word 1	72
8.8	Fault Word 2	72
8.9	Warning Word 1	73
8.10	Auxiliary Control Word	74
8.11	Auxiliary Control Word (in DeviceNet)	75
8.12	FB Reference Control (Device net)	76
8.13	Aux Status Word ID 1163	77
8.14	Status Word (Application) ID 43	78
9.	Fault codes	80

1. INTRODUCTION

The AFE unit is a regenerative power converter for the front-end of a common DC bus product line. The AFE unit is used with inverter hardware and special software. An external L(CL)-filter and charging circuit is needed. This unit is selected when low harmonics are required. The connection of AFE drive has been described in Figure .

The Regenerative Application is easy and flexible to use due to its versatile fieldbus features. The parameters of the Regenerative Application are explained in Chapter 8.

The basic I/O-configuration of the AFE drive consists of OPT-A1 and OPT-A2 option cards. The basic I/O configuration has been described in Table 5. An option card OPT-B5 can be used if additional digital outputs are needed. Configuration has been described in Table 6.

By default the control place (P3.1) of the AFE drive is keypad.

This application requires NXP control board 661 or 761.

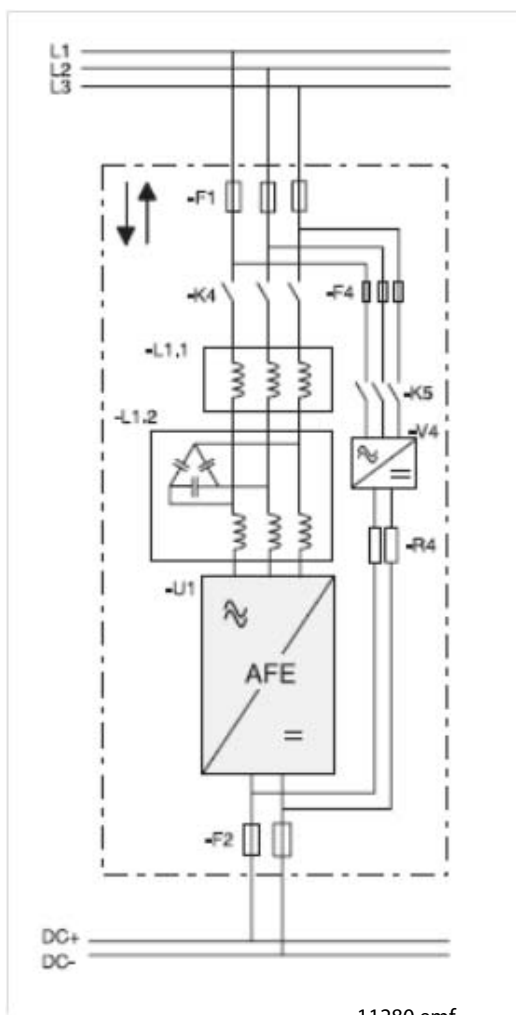

11280.emf

Figure 1. AFE connection

2. AFE UNITS

2.1 500 VAC UNITS AIR COOLED

Table 1. 500 Vac units Air Cooled

Unit			
Code	Enclosure size	IL-cont [A]	IH-cont [A]
NXA_0168 5 A0T02SF	1xFI9	170	140
NXA_0205 5 A0T02SF	1xFI9	205	170
NXA_0261 5 A0T02SF	1xFI9	261	205
NXA_0385 5 A0T02SF	1xFI10	385	300
NXA_0460 5 A0T02SF	1xFI10	460	385
NXA_1150 5 A0T02SF	1xFI13	1150	1030
NXA_1300 5 A0T02SF	1xFI13	1300	1150

2.2 690 VAC UNITS AIR COOLED

Table 2. 690 Vac units Air Cooled

Unit			
Code	Enclosure size	IL-cont [A]	IH-cont [A]
NXA_0125 6 A0T02SF	1xFI9	125	100
NXA_0144 6 A0T02SF	1xFI9	144	125
NXA_0170 6 A0T02SF	1xFI9	170	144
NXA_0261 6 A0T02SF	1xFI10	261	208
NXA_0325 6 A0T02SF	1xFI10	325	261
NXA_0920 6 A0T02SF	1xFI13	920	820
NXA_1030 6 A0T02SF	1xFI13	1030	920

2.3 500 VAC UNITS LIQUID-COOLED

Table 3. 500 Vac units Liquid-Cooled

Unit				
Code	Chassis	Ith-cont [A]	IL-cont [A]	IH-cont [A]
NXA01685A0T02WS	CH5	168	153	112
NXA02055A0T02WS	CH5	205	186	137
NXA02615A0T02WS	CH5	261	237	174
NXA03005A0T02WF	CH61	300	273	200
NXA03855A0T02WF	CH61	385	350	257
NXA04605A0T02WF	CH62	460	418	307
NXA05205A0T02WF	CH62	520	473	347
NXA05905A0T02WF	CH62	590	536	393
NXA06505A0T02WF	CH62	650	591	433
NXA07305A0T02WF	CH62	730	664	487
NXA08205A0T02WF	CH63	820	745	547
NXA09205A0T02WF	CH63	920	836	613
NXA10305A0T02WF	CH63	1030	936	687
NXA11505A0T02WF	CH63	1150	1045	767
NXA13705A0T02WF	CH64	1370	1245	913
NXA16405A0T02WF	CH64	1640	1491	1093
NXA20605A0T02WF	CH64	2060	1873	1373
NXA23005A0T02WF	CH64	2300	2091	1533

2.4 690 VAC UNITS LIQUID-COOLED

Table 4. 690 Vac units Liquid-Cooled

Unit				
Code	Chassis	Ith-cont [A]	IL-cont [A]	IH-cont [A]
NXA01706A0T02WF	CH61	170	155	113
NXA02086A0T02WF	CH61	208	189	139
NXA02616A0T02WF	CH61	261	237	174
NXA03256A0T02WF	CH62	325	295	217
NXA03856A0T02WF	CH62	385	350	257
NXA04166A0T02WF	CH62	416	378	277
NXA04606A0T02WF	CH62	460	418	307
NXA05026A0T02WF	CH62	502	456	335
NXA05906A0T02WF	CH63	590	536	393
NXA06506A0T02WF	CH63	650	591	433
NXA07506A0T02WF	CH63	750	682	500
NXA08206A0T02WF	CH64	820	745	547
NXA09206A0T02WF	CH64	920	836	613
NXA10306A0T02WF	CH64	1030	936	687
NXA11806A0T02WF	CH64	1180	1073	787
NXA13006A0T02WF	CH64	1300	1182	867
NXA15006A0T02WF	CH64	1500	1364	1000
NXA17006A0T02WF	CH64	1700	1545	1133

3. OPERATION

3.1 MAIN CONTACTOR CONTROL

The AFE application controls the main contactor of the system with Relay Output R02. When charging of the DC bus is ready, the main contactor will be closed. The status of the main contactor is monitored via digital input (Default is DIN4). The digital input used for monitoring is chosen with parameter P2.3.1.4.

NOTE! Main Contactor feedback is required for correct AFE functionality.

Faults can be set to open the main contactor by selecting the response "3=Fault, DC OFF". When a fault occurs, the drive will open Relay Output R02 that controls the main contactor after one second (See wiring details from VACON® NX Active Front End User Manual). Thus the drive will stop modulating before an open command is given. If the DC is still high enough when a fault reset is given, the drive will close the Relay Output R02.

An external charging circuit is needed to charge the DC bus.

The AFE start up sequence has been illustrated in Figure and fault handling in Figure .

3.2 QUICK START INSTRUCTIONS

NOTE! Before taking any commissioning actions, read carefully the safety instructions in VACON® NXS/P User Manual.

1. Connect the unit according to Figure .
2. Power up the control unit
3. Set Basic parameters G2.1 (see Table 21).
4. Check that the digital input parameters (P2.3.1.1 - P2.3.1.10) have been set according to connections. All the unused input signals must be set to "0 = Not used" state, except for the main contactor feedback which must be used.
5. Change the control place to I/O (P3.1).
6. Precharge the unit.

In case of parallel AFE:

1. Set the Parallel AFE parameter (P2.1.4) = YES (in every AFE). (This will set also DC Drooping to 4.00%)
2. Set the Start Up Delay in AFE units so that starting is in sequence with e.g. 500 ms intervals.
Figure 2.

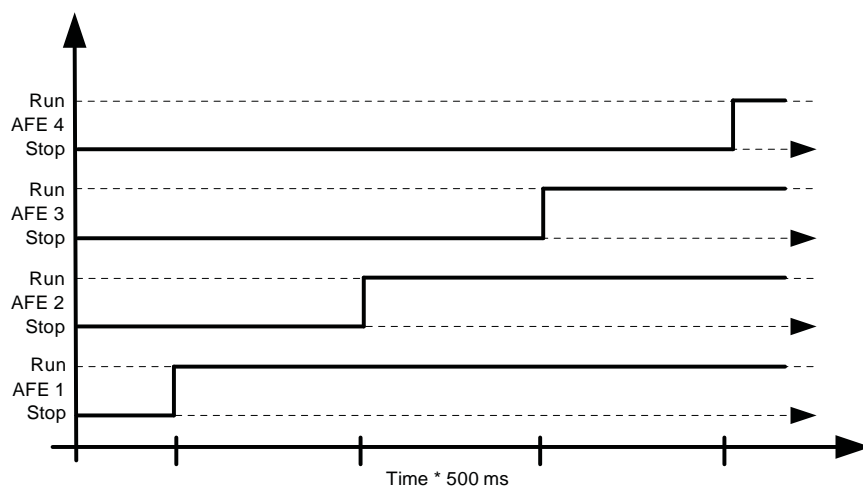

11281.emf

Figure 3. Setting the Start Up Delay in AFE units

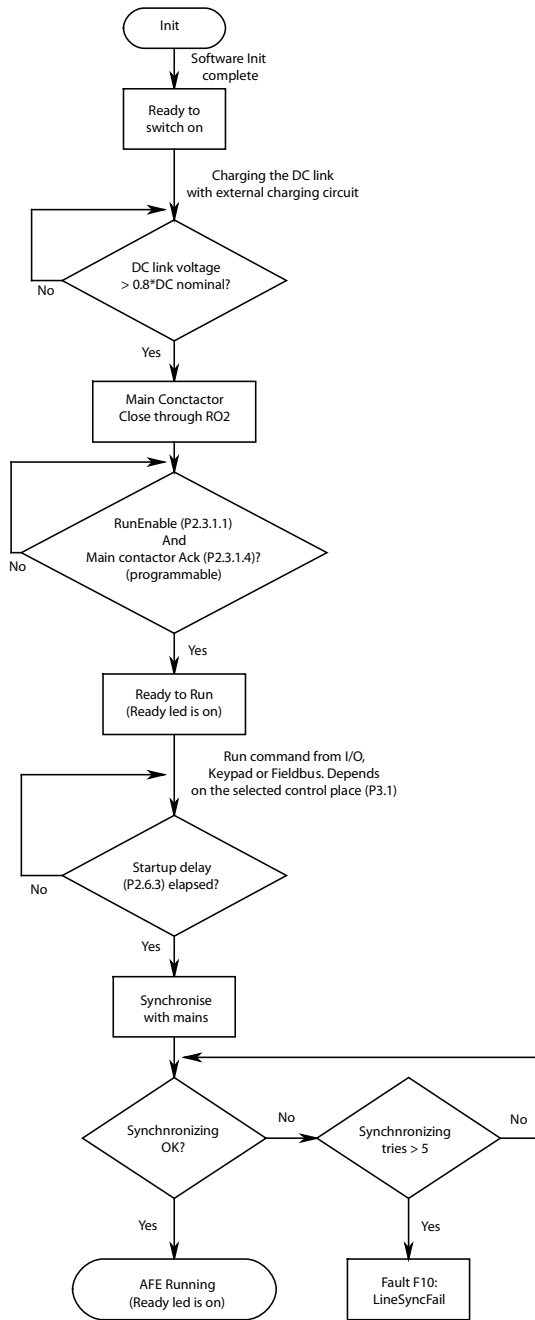

11282.emf

Figure 4. AFE start sequence

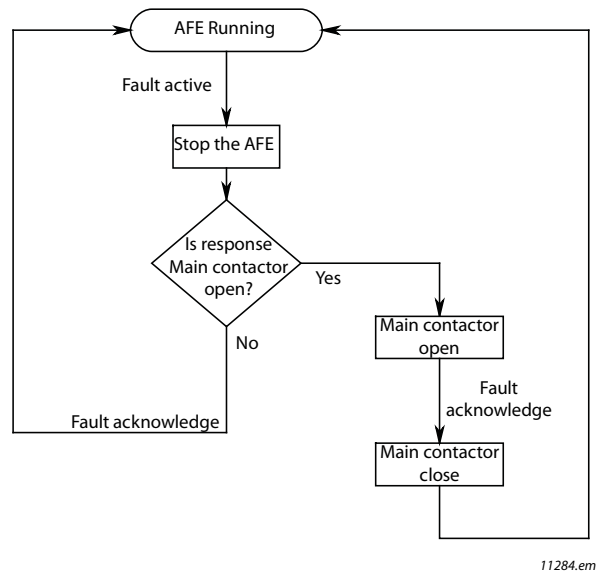

Figure 5. Fault handling in AFE application

4. CONTROL I/O

Table 5. Default I/O configuration

NXOPTA1			
Terminal	Signal	Signal	Description
1	+10 Vref	Reference voltage output	Voltage for potentiometer, etc.
2	AI1+	Analogue input 1. Range 0-10V, $R_i = 200\Omega$ Range 0-20 nA, $R_i = 250\Omega$	Analogue input 1 Input range selected by jumpers. Default range: Voltage 0-10 V
3	AI1-	I/O ground	Ground for reference and controls
4	AI2+	Analogue input 2. Range 0-10V, $R_i = 200\Omega$ Range 0-20 nA, $R_i = 250\Omega$	Analogue input 2 Input range selected by jumpers. Default range: Current 0 - 20 mA
5	AI2-		
6	+24V	Voltage for switches, etc. max 0.1 A	
7	GND	I/O ground	Ground for reference and controls
8	DIN1	Start Request Programmable G2.3.1	Contact closed = Start Request
9	DIN2	Programmable G2.3.1	No function defined at default
10	DIN3	Programmable P2.3.1	No function defined at default
11	CMA	Common for DIN 1—DIN 3	Connect to GND or +24V
12	+24V	Control voltage output	Voltage for switches (see #6)
13	GND	I/O ground	Ground for reference and controls
14	DIN4	Main Contactor Acknowledge Programmable G2.2.1	Contact closed = MCC Closed
15	DIN5	Programmable G2.3.1	No function defined at default
16	DIN6	Fault Reset Programmable G2.3.1	Rising edge will reset active faults.
17	CMB	Common for DIN4—DIN6	Connect to GND or +24V
18	AOA1+	Analogue output 1 Programmable G2.3.1	Output range selected by jumpers. Range 0—20 mA, R_L , max. 500 Ω Range 0—10 V, $R_L > 1k\Omega$
19	AOA1-		
20	DOA1	Digital output Ready/Warning (Blinking)	Programmable Open collector, 450mA, $U \leq 48$ VDC
NXOPTA2			
21	RO 1	Relay output 1 Run State Programmable G2.4.2	Switching capacity 24 VDC / 8 A 250 VAC / 8 A 125 VDC / 0.4 A
22	RO 1		
23	RO 1		
24	RO 2	Relay output 2 Main Contactor Control Cannot be reprogrammed G2.4.1	Fixed to main contactor control. Closes when DC at 80 % of nominal DC. Opens when DC below 75 % of nominal DC
25	RO 2		
26	RO 2		

9429_uk

The default I/O configuration if the option card PT-B5 is used:

Table 6. Default I/O configuration

OPT-B5				
22	RO 1• common		Relay output 1 Fault	Switching capacity 24VDC/8A• 250VAC/8A• 125VDC/0.4A
23	RO 1 NO			
25	RO 2• common		Relay output 2 Warning	Switching capacity 24VDC/8A• 250VAC/8A• 125VDC/0.4A
26	RO 2			
28	RO 3• common		Relay output 3 Temperature warning	Switching capacity 24VDC/8A• 250VAC/8A• 125VDC/0.4A
29	RO 3			

9430_uk

5. AFE APPLICATION - MONITORING VALUES

This chapter presents the lists of parameters within the respective parameter groups.

Column explanations

Code	= Location indication on the keypad; shows the operator the present parameter number
Parameter	= Name of the parameter
Min	= Minimum value of the parameter
Max	= Maximum value of the parameter
Unit	= Unit of the parameter value; given if available
Default	= Value preset by factory
Cust	= Customer's own setting
ID	= ID number of the parameter

The manual presents the signals that are not normally visible for monitoring. These are not parameters or standard monitoring signals. These signals are presented with [Letter], e.g. [FW]Motor-RegulatorStatus.

- [V]** Normal monitoring signal
- [P]** Normal parameter in application.
- [FW]** Firmware signal, can be monitored with NCDrive when signal type Firmware is selected
- [A]** Application signal, can be monitored with NCDrive when signal type Application is selected
- [R]** Reference type parameter on keypad.
- [F]** Function. Signal is received as an output of function.
- [DI]** Digital input signal.

5.1 MONITORING VALUES

The monitoring values are actual values of parameters and signals as well as statuses and measurements. Monitoring values cannot be edited.

5.1.1 MONITORING 1

Table 7. Monitoring 1

Code	Signal	Unit	ID	Description
V1.1.1	DC Voltage	V	1108	Measured DC Link voltage in Volts
V1.1.2	Used DC Voltage Reference	%	1200	Used DC voltage reference by the regenerative unit in percentage of Nominal DC Voltage. Nominal DC voltage = 1.35 * Supply voltage
V1.1.3	Total Current	A	1104	Total current of the regenerative unit in Amperes.
V1.1.4	Active Current	%	1125	Reactive current of the regenerative drive in percentage of Rated Line Current. > 0 power from AC side to DC side < 0 power from DC side to AC side
V1.1.5	Reactive Current	%	1157	Reactive current of the regenerative drive in percentage of Rated Line Current. > 0 Inductive current < 0 Capacitive current
V1.1.6	Active Power	kW	1511	> 0 power from AC side to DC side < 0 power from DC side to AC side
V1.1.7	Power %	%	5	> 0 power from AC side to DC side < 0 power from DC side to AC side
V1.1.8	Status Word		43	
V1.1.9	Supply Frequency	Hz	1101	Supply frequency in ###.## Hz. The sign indicates the phase order.
V1.1.10	Supply Voltage	V	1107	Input AC voltage, RMS line to line Volts.
V1.1.11	Line Frequency D7	Hz	1654	Measured line frequency by OPT-D7
V1.1.12	Line Voltage D7	V	1650	Measured line voltage by OPT-D7
V1.1.13	D7 Synch.Error		1659	Signed phase difference compared to measurement with optD7 card (-3072...3071) = -180...180deg

5.1.2 MONITORING VALUES 2*Table 8. Monitoring values 2*

Code	Signal	Unit	ID	Description
V1.2.1	Unit Temperature	°C	1109	Heat sink temperature
V1.2.2	Current	A	1113	Unfiltered current
V1.2.3	DC Voltage	V	44	Unfiltered DC Voltge
V1.2.4	Operation Hours	h	1856	Operation hours in format of #,##
V1.2.5	Reactive Current Reference	%	1389	Used reactive current reference 100.0 = Rated Line Current
V1.2.6	Line Votlage THD	%	1670	Total harmonic distortion of the line voltage

5.1.3 FIELDBUS MONITORING VALUES*Table 9. FieldBus Monitoring values*

Code	Signal	Unit	ID	Description
V1.3.1	Main Control Word		1160	Control word from fieldbus
V1.3.2	Main Status Word		1162	Status word to fieldbus
V1.3.3	Fault Word 1		1172	
V1.3.4	Fault Word 2		1173	
V1.3.5	Warning Word 1		1174	Alarm Word 1
V1.3.6	Warning		74	Last active warning code
V1.3.7	Fault History		37	Last active fault
V1.3.8	Aux Control Word 1		1161	
V1.3.9	Aux Status Word		1163	

5.1.4 IO MONITORING VALUES*Table 10. IO Monitoring values*

Code	Signal	Unit	ID	Description
V1.4.1	DIN1, DIN2, DIN3		15	Digital Inputs A1, A2 and A3 Status (sum)
V1.4.2	DIN4, DIN5, DIN6		16	Digital Inputs B4, B5 and B6 Status (sum)
V1.4.3	DIN Status 1		56	
V1.4.4	DIN Status 2		57	
V1.4.5	Analogue Input 1	%	13	
V1.4.6	Analogue Input 2	%	14	
V1.4.7	Analogue Out 1	%	26	
V1.4.8	PT100 Temp. 1	°C	50	
V1.4.9	PT100 Temp. 2	°C	51	
V1.4.10	PT100 Temp. 3	°C	52	

Table 10. IO Monitoring values

Code	Signal	Unit	ID	Description
V1.4.11	D01, R01, R02		17	Digital Output and Relay 1&2 Status (sum)

5.1.5 UNIT MONITORING VALUES

Table 11. Unit Monitoring Values

Code	Signal	Unit	ID	Description
V1.5.1	Unit Nominal Voltage	V	1117	Unit rated AC Voltage
V1.5.2	Unit Nominal Current	A	1118	
V1.5.3	U Phase Current	A	1149	U Phase RMS current
V1.5.4	V Phase Current	A	1150	V Phase RMS current
V1.5.5	W Phase Current	A	1151	W Phase RMS current

5.1.6 MONITORING 1 VALUES**V1.1.1 DC-LINK VOLTAGE [# V] ID 1108**

Measured DC voltage, filtered.

V1.1.2 USED DC VOLTAGE REFERENCE [#,#%] ID 1200

Used DC voltage reference by the regenerative unit in percentage of Nominal DC Voltage.

Nominal DC Voltage = Supply Voltage * 1.35

DC Voltage = Supply Voltage * 1.35 * Boost

e.g.

621 Vdc = 400 Vac * 1.35 * 1.15

V1.1.3 TOTAL CURRENT [A] ID 1104

Total current of the regenerative unit in Amperes, filtered.

V1.1.4 ACTIVE CURRENT [#,#%] ID 1125

Active current in percentage of System Rated Current. A negative value means that the current is flowing to AC side from DC side i.e. regenerating.

V1.1.5 REACTIVE CURRENT [#,#%] ID 1157

Reactive current of the regenerative drive in percentage of System Rated Current.

Positive value means Inductive current.

Negative value means capacitive current.

V1.1.6 POWER KW [KW] ID 1511

Drive output power in kW.

A negative value means that current is flowing to AC side from DC side i.e. regenerating.

V1.1.7 POWER % [#,# %] ID 5

Drive output power in percentage.

A negative value means that current is flowing to AC side from DC side i.e. regenerating.

V1.1.8 STATUS WORD (APPLICATION) ID 43

Application Status Word combines different drive statuses to one data word.

Table 12. Application Status Word

	FALSE	TRUE
b0		
b1	Not in Ready state	Ready
b2	Not Running	Running
b3	No Fault	Fault
b4	Positive frequency	Negative frequency
b5	No fault or AutoResetFault	Fault or Auto Reset Fault
b6	Run Disabled	Run Enable
b7	No Warning	Warning
b8		Charging Switch closed (internal)
b9		Main Contactor Control (DO Final)
b10		Main Contactor Feedback
b11		
b12	No Run Request	Run Request
b13	Motoring Side	Generator Side
b14		F1, F31 or F41 active
b15		

V1.1.9 SUPPLY FREQUENCY [# ,## Hz] ID 1101

Supply frequency in ##.## Hz .The sign indicates the phase order. Updated when the drive is in run state. Updated also in stop state when OPT-D7 is used or Regen Options B9 is activated.

V1.1.10 SUPPLY VOLTAGE [# ,# V] ID 1107

Input AC voltage, RMS line to line Volts. Updated when the drive is in run state.

Updated also when OPT-D7 is used.

V1.1.11 LINE FREQUENCY [# ,## Hz] ID 1654

Measured Line Voltage Frequency when using OPT-D7 option board in slot C.

V1.1.12 LINE VOLTAGE [# V] ID 1650

Measured line voltage rms value when using OPT-D7 option board in slot C.

V1.1.13 D7 SYNCH ERROR [# V] ID 1659

Voltage angle error between OPT-D7 line voltage and AFE unit voltage. If error is not close to zero when in run state phase order of OPT-D7 may be wrong.

5.1.7 MONITORING 2 VALUES

V1.2.1 UNIT TEMPERATURE [# °C] ID 1109

Temperature of the unit in degrees Celsius.

V1.2.2 CURRENT [A] ID 1113

Unfiltered current of the drive.

V1.2.3 DC VOLTAGE [# V] ID 44

Unfiltered DC Voltage.

V1.2.4 OPERATION HOURS [#,# # H] ID1856

This shows operation hours of the drive. P2.6.7 is used to enter the old value if software is updated.

V1.2.5 REACTIVE CURRENT REFERENCE [#,# %] ID1389

Used reactive current reference 100.0 = Rated Line Current.

Positive value means Inductive current.

Negative value means capacitive current.

V1.2.6 LINE VOLTAGE THD ID1670

OPT-D7 measured line voltage THD.

5.1.8 FIELDBUS MONITORING VALUES

V1.3.1 MAIN CONTROL WORD ID 1160

Control word from fieldbus. The table below is for the bypass operation for such fieldbus board that natively supports this or can be parameterized to bypass mode.

Table 13. Main Control Word

FALSE		TRUE
b0	DC charge Contactor close	0= No Action 1= Close DC charge contactor
b1	OFF2 =Stop	0=stop Active. Regenerative control is stopped. 1=stop not active
b2		Reserved for future use.
b3	Run	0= Drive stop command 1= Drive start command
b4		Reserved for future use.
b5		Reserved for future use.
b6		Reserved for future use.
b7	Reset	0>1 Reset fault.
b8	Set DC Voltage Ref 1	DC Voltage Reference 1, see details in Chapter 8.4 "FB Reference Control".
b9	Set DC Voltage Ref 2	DC Voltage Reference 2, see details in Chapter 8.4 "FB Reference Control".
b10	Fieldbus Control	0= No control from fieldbus 1=Control from fieldbus
b11	Watchdog	0>1>0>1...1 sec square wave clock. This is used to check the data communication between fieldbus master and the drive. Used to generate FB Comm. Fault. This monitoring can be switched off by setting P2.8.4.2 FB Watchdog Delay=0. The drive's internal communication monitoring is still active at this time.
b12		Reserved for future use.
b13		Reserved for future use.
b14		Reserved for future use.
b15		Reserved for future use.

V1.3.1 MAIN CONTROL WORD (IN DEVICENET) ID 1160

Table 14. Main Control Word (in DeviceNet)

	FALSE	TRUE
b0	Run	0= Drive stop command 1= Drive start command
b1		
b2	Reset	0>1 Reset fault.
b3		
b4		
b5	Fieldbus Control	0= No control from fieldbus 1=Control from fieldbus
b6		
b7		
b8		
b9		
b10		
b11		
b12		
b13		
b14		
b15		

V1.3.2 MAIN STATUS WORD ID 1162

Status word to fieldbus. The table below gives details for the bypass operation of such fieldbus boards that natively support this or can be parameterized to bypass mode.

Table 15. Main Status Word

	FALSE	TRUE
b0	Ready On	0=Drive not ready to switch on 1=Drive ready to switch Main Contactor ON
b1	Ready Run	0=Drive not ready to run 1=Drive ready and Main Contactor is ON
b2	Running	0=Drive not running 1=Drive in Run state (Modulating)
b3	Fault	0=No active fault 1=Fault is active
b4	Off2 Status	0= Run Disabled. Drive in stop state 1= Run Enabled. Drive can be started.
b5		Reserved for future use.
b6		Reserved for future use.
b7	Warning	0= No active warnings 1= Warning active
b8	At Reference	0= DC Voltage Ref and Act DC Voltage are not same.
b9	Fieldbus Control Active	0=Fieldbus control not active 1=Fieldbus control active
b10	Above Limit	0= DC Voltage is below the level specified by P2.5.6.1 1=The DC Voltage is above the specified level by P2.5.6.1
b11		Reserved for future use.
b12		Reserved for future use.
b13		Reserved for future use.
b14		Reserved for future use.
b15	Watchdog	Same as received on bit 11 of the main control word.

V1.3.3 FAULT WORD 1 ID 1172

Table 16. Fault Word 1

	FALSE	TRUE
b0	Over Current	F1
b1	Overvoltage	F2
b2	Under voltage	F9
b3	Not used	
b4	Earth Fault	F3
b5	Not used	
b6	Unit Over Temperature	F14
b7	Over Temperature	F59, F56, F71
b8	Input Phase loss	F11
b9	Not used	
b10	Device Fault	F37, F38, F39, F40, F44, F45
b11	Not used	
b12	Not used	
b13	Not used	
b14	Not used	
b15	Not used	

V1.3.4 FAULT WORD 2 ID 1173

Table 17. Fault Word 2

	FALSE	TRUE
b0	Not used	
b1	Charging Switch Fault	F5
b2	Not used	
b3	Drive Hardware fault	F4, F7
b4	Under Temperature	F13
b5	EPR0M or Checksum fault	F22
b6	External fault	F51
b7	Not used	
b8	Internal Communication	F25
b9	IGBT Temperature	F31, F41
b10	Not used	
b11	Cooling fan	F32, F70
b12	Application fault	F35
b13	Drive Internal fault	F33, F36, F8, F26
b14	Main Switch open	F64
b15	Not used	

V1.3.5 WARNING WORD 1 ID 1174*Table 18. Warning Word 1*

	FALSE	TRUE
b0	Not used	
b1	Temperature protection	W29: Thermistor warning, W56: FPT100 warning or W71: LCL over temperature warning
b2		
b3	Supply Phase Warning	W11
b4	Not used	
b5	Not used	
b6	Not used	
b7	Drive over temperature	W14
b8	Not used	
b9	Not used	
b10	Fan Warning	W32: Fan Cooling W70: LCL Fan monitor warning
b11	Not used	
b12	Not used	
b13	Not used	
b14	Not used	
b15	Not used	

V1.3.6 WARNING ID74

Last active warning number.

V1.3.7 LAST ACTIVE FAULT ID37

Last active fault number.

V1.3.8 **AUX CONTROL WORD ID 1161***Table 19. Aux Control Word*

FALSE		TRUE
b0		Reserved for future use.
b1		Reserved for future use.
b2		Reserved for future use.
b3		Reserved for future use.
b4		Reserved for future use.
b5		Reserved for future use.
b6		Reserved for future use.
b7		Reserved for future use.
b8		Reserved for future use.
b9		Reserved for future use.
b10		Reserved for future use.
b11		Reserved for future use.
b12	Enable DC Level control from MCW	0 = DC Voltage Level control from Main Control Word (MCW) is not active and DC Voltage reference is from fieldbus data (reference value). 1 = DC Voltage Level control from MCW is enabled
b13	DO control	This signal can be connected to digital output with parameters in G2.4.1
b14		Reserved for future use.
b15		Reserved for future use.

V1.3.8 AUX CONTROL WORD (IN DEVICE NET) ID 1161

Table 20. Auxiliary Control Word (in DeviceNet)

FALSE		TRUE
b0	DC charge Contactor close	0 = No Action 1 = Close DC charge contactor
b1	OFF2 =Stop	0 =stop Active. Regenerative control is stopped. 1 =stop not active
b2	Set DC Voltage Ref 1	DC Voltage Reference 1. For details, see Chapter 8.4 "FB Reference Control".
b3	Set DC Voltage Ref 2	DC Voltage Reference 2, see detail from Chapter 8.4 "FB Reference Control".
b4	Watchdog	0>1>0>1...1 sec square wave clock. This is used to check data communication between fieldbus master and the drive. Used to generate FB Comm. Fault. This monitoring can be switched off by setting P2.8.4.2 FB Watchdog Delay=0. The drive's internal communication monitoring is still active at this time.
b5		Reserved for future use.
b6		Reserved for future use.
b7		Reserved for future use.
b8		Reserved for future use.
b9		Reserved for future use.
b10		Reserved for future use.
b11		Reserved for future use.
b12	Enable DC Level control from MCW	0 = DC Voltage Level control from Main Control Word (MCW) is not active and DC Voltage reference is from fieldbus data (reference value). 1 = DC Voltage Level control from MCW is enabled
b13	DO control	This signal can be connected to digital output with parameters in G2.4.1
b14		Reserved for future use.
b15		Reserved for future use.

V1.3.9 AUX STATUS WORD ID 1163

Reserved for future use.

5.1.9 I0 MONITORING VALUES

V1.4.1 **DIN1, DIN2, DIN3 ID 15**

V1.4.2 **DIN4, DIN5, DIN6 ID 16**

DIN1/DIN2/DIN3 status		DIN4/DIN5/DIN6 status
b0	DIN3	DIN6
b1	DIN2	DIN5
b2	DIN1	DIN4

V1.4.3 **DIN STATUS 1 ID 56**

V1.4.4 **DIN STATUS 2 ID 57**

DIN Status Word 1		DIN Status Word 2
b0	DIN: A.1	DIN: C.5
b1	DIN: A.2	DIN: C.6
b2	DIN: A.3	DIN: D.1
b3	DIN: A.4	DIN: D.2
b4	DIN: A.5	DIN: D.3
b5	DIN: A.6	DIN: D.4
b6	DIN: B.1	DIN: D.5
b7	DIN: B.2	DIN: D.6
b8	DIN: B.3	DIN: E.1
b9	DIN: B.4	DIN: E.2
b10	DIN: B.5	DIN: E.3
b11	DIN: B.6	DIN: E.4
b12	DIN: C.1	DIN: E.5
b13	DIN: C.2	DIN: E.6
b14	DIN: C.3	
b15	DIN: C.4	

V1.4.5 **ANALOGUE INPUT 1 [#,## %] ID13**

V1.4.6 **ANALOGUE INPUT 2 [#,## %] ID14**

Unfiltered analogue input level.

0% = 0 mA / 0 V, -100% = -10 V, 100% = 20 mA / 10 V.

Monitoring scaling is determined by the option board parameter.

V1.4.7 **ANALOGUE OUT 1 [#,## %] ID 26**

Analogue Output value 0% = 0 mA / 0 V, 100% = 20 mA / 10 V.

V1.4.8 **PT100 TEMP. 1 [#,# °C] ID 50**

V1.4.9 **PT100 TEMP. 2 [#,# °C] ID 51**

V1.4.10 **PT100 TEMP. 3 [#,# °C] ID 52**

Separate measurement from PT100 board. The signal has 4 s filtering time.

V1.4.11 **DO1, RO1, RO2 ID 17**

Digital Output and Relay 1&2 Status (sum).

5.1.1.10 **UNIT MONITORING VALUES**

V1.5.1 **UNIT NOMINAL VOLTAGE [# V] ID 1117**

Unit rated AC voltage in volts.

V1.5.2 **UNIT NOMINAL CURRENT [A] ID 1118**

Nominal current rating of the converter in Amperes. Unit Ih Current.

V1.5.3 **U PHASE CURRENT [A] ID 1149**

U Phase RMS current.

V1.5.4 **V PHASE CURRENT [A] ID 1150**

V Phase RMS current.

V1.5.5 **W PHASE CURRENT [A] ID 1151**

W Phase RMS current.

6. AFE APPLICATION - PARAMETER LISTS

This chapter presents the lists of parameters within the respective parameter groups.

Column explanations

Code	= Location indication on the keypad; shows the operator the present parameter number
Parameter	= Name of the parameter
Min	= Minimum value of the parameter
Max	= Maximum value of the parameter
Unit	= Unit of the parameter value; given if available
Default	= Value preset by factory
Cust	= Customer's own setting
ID	= ID number of the parameter

The manual presents the signals that are not normally visible for monitoring. These are not parameters or standard monitoring signals. These signals are presented with [Letter], e.g. [FW]Motor-RegulatorStatus.

- [V]** Normal monitoring signal
- [P]** Normal parameter in application.
- [FW]** Firmware signal, can be monitored with NCDrive when signal type Firmware is selected
- [A]** Application signal, can be monitored with NCDrive when signal type Application is selected
- [R]** Reference type parameter on keypad.
- [F]** Function. Signal is received as an output of function.
- [DI]** Digital input signal.

6.1 BASIC PARAMETERS

Table 21. Basic parameters

Code	Parameter	Min	Max	Unit	Default	ID	Note
P2.1.1	Rated Line Voltage	500V: 380V 690V: 525V	500V: 50V 690V: 690V	V	500V: 400 690 V: 690 V	1201	Set here the nominal voltage of the grid.
P2.1.2	Rated Line Current	0.0	I_L	A	I_H	113	Capacity of supply, used if oversized AFE.
P2.1.3	Rated Line Power	0	32000	kW	0	116	Motor nominal shaft power.
P2.1.4	Parallel AFE	0	1		0	1501	0 = single AFE 1 = parallel AFE Activation will set DC Drooping to 4%.

6.2 REFERENCE HANDLING

Table 22. Reference handling

Code	Parameter	Min	Max	Unit	Default	ID	Note
P2.2.1	DC Voltage Ref.	500V: 105% 690V: 105%	500V: 130% 690V: 115%	%	110.00	1462	DC Voltage reference as percentage of Nominal DC Voltage Nominal DC voltage = 1.35 * Supply voltage
P 2.2.2	DC Voltage Drooping	0.00	100.00		0.00	620	AFE drooping DC-voltage. Set to 4.00% when parallel AFE operation is selected
P 2.2.3	Reactive Current Reference Selector	0	2		0	1384	Reactive current reference source: 0 = Panel 1 = Analogue Input 1 2 = Analogue Input 2
P2.2.4	ReactiveCurr.Ref	-100.0	100.0	%	0.0	1459	Regenerative reactive current reference 100.0 = nominal current. Positive = Inductive Negative = Capacitive

6.3 INPUT SIGNALS

6.3.1 DIGITAL INPUTS

Table 23. Digital input parameters

Code	Parameter	Min	Max	Unit	Default	ID	Description
P2.3.1.1	Run Request	0	6		1	1206	0 = Not used 1 = DIN1 2 = DIN2 3 = DIN3 4 = DIN4 5 = DIN5 6 = DIN6
P2.3.1.2	Open Contactor (Forced Open)	0	12		0	1508	0 = Not used 1 = DIN1 2 = DIN2 3 = DIN3 4 = DIN4 5 = DIN5 6 = DIN6 7 = DIN1 (inverted) 8 = DIN2 (inverted) 9 = DIN3 (inverted) 10 = DIN4 (inverted) 11 = DIN5 (inverted) 12 = DIN6 (inverted)
P2.3.1.3	LCL Temperature monitoring X52	0	12		0	1179	As par. P2.3.1.2
P2.3.1.4	Main contactor Acknowledge	0	6		4	1453	0 = 3s start Delay 1 = DIN1 2 = DIN2 3 = DIN3 4 = DIN4 5 = DIN5 6 = DIN6
P2.3.1.5	LCL Fan Monitoring (X51)	0	12		0	1178	As par. P2.3.1.2
P2.3.1.6	Fault Reset	0	6		6	1208	As par. P2.3.1.1
P2.3.1.7	External fault	0	12		0	1214	As par. P2.3.1.2
P2.3.1.8	Run Enable	0	6		0	1212	As par. P2.3.1.1
P2.3.1.9	Cooling Monitor	0	6		0	750	OK input from the cooling unit
P2.3.1.10	LCL Temperature monitoring X51	0	12		0	1180	As par. P2.3.1.2

6.3.2 ANALOGUE INPUTS

Table 24. Analogue input parameters

Code	Parameter	Min	Max	Unit	Default	ID	Description
P2.3.2.1	Analogue Input 1 Minimum	0	1		0	1227	Minimum voltage or Current at AI1. 0 = 0 V / 0 A 1 = 2 V / 4 mA
P2.3.2.2	Analogue Input 1 Filter Time	0.00	10.00	s	1.00	1228	Filter time for AI1 in ###.## sec. 0 = No filtering
P2.3.2.3	Analogue Input 2 Minimum	0	1		0	1231	Minimum voltage or Current at AI2 in. 0 = 0 V / 0 A 1 = 2 V / 4 mA
P2.3.2.4	Analogue Input 2 Filter Time	0.00	10.00	s	1.00	1232	Filter time for AI2 ###.## sec. 0 = No filtering

6.4 OUTPUT SIGNALS

6.4.1 DIGITAL OUTPUTS

Table 25. Digital output parameters

Code	Parameter	Min	Max	Unit	Default	ID	Description
P2.4.1.1	Digital output 1 function	0	11		9	1216	Signal selection for DO1. 0 = DO Control from FB (AuxControlWord, bit 13) 1 = Ready 2 = Running 3 = Fault 4 = No Fault 5 = Warning 6 = At Reference 7 = Regen Active 8 = Charge DC 9 = Ready / Warning (blink). 10 = Temperature Warning. 11 = DC Voltage Above Limit
P2.4.1.2	Relay Output 1 function	0	11		2	1217	Signal selection for the digital indication through R01.
P2.4.1.3	Relay Output 2 function	0	0		0	1218	Main Contactor Control Slot B, Output 2 This parameter cannot be changed.
P2.4.1.4	D04	0	11		3	1385	Digital Output 4 function
P2.4.1.5	D05	0	11		5	1386	Digital Output 5 function
P2.4.1.6	D06	0	11		10	1390	Digital Output 6 function
P2.4.1.7	D07	0	11		0	1391	Digital Output 7 function
P2.4.1.8	D08	0	11		0	1395	Digital Output 8 function
P2.4.1.9	D09	0	11		0	1396	Digital Output 9 function
P2.4.1.10	D010	0	11		0	1423	Digital Output 10 function
P2.4.1.11	D011	0	11		0	1427	Digital Output 11 function
P2.4.1.12	D012	0	11		0	1428	Digital Output 12 function
P2.4.1.13	D013	0	11		0	1429	Digital Output 13 function

6.4.2 ANALOGUE OUTPUT 1

Table 26. Analog Output 1 parameters

Code	Parameter	Min	Max	Unit	Default	ID	Description
P2.4.2.1	A01 Signal ID	0	2000		0	1233	Set the ID no. of a signal to be connected to A01.
P2.4.2.2	A01 Offset	0	1		0	1234	Minimum voltage or current at A01. 0= 0V/0mA. 1= 2V/4mA
P2.4.2.3	A01 Filter	0.02	10.00	s	10.00	1235	Filter time for A01 in ##.## sec.
P2.4.2.4	A01 Max Value	-30000	30000		1500	1236	Maximum value of a signal connected to A01. This will correspond to +10V/20mA.
P2.4.2.5	A01 Min Value	-30000	30000		0	1237	Minimum value of a signal connected to A01. This will correspond to 0V/0mA or 2V/4mA depending on the A01 Offset

6.5 LIMIT SETTINGS

6.5.1 CURRENT LIMIT

Table 27. Current Limit

Code	Parameter	Min	Max	Unit	Default	ID	Description
P2.5.1.1	Current Limit	0	Varies	A	I_L	107	Total current limit

6.5.2 POWER LIMIT

Table 28. Power Limit

Code	Parameter	Min	Max	Unit	Default	ID	Description
P 2.5.2.1	Power Limit Motoring Side	0	300	%	300	1289	Motoring power limit in AFE mode to DC-link.
P 2.5.2.2	Power Limit Generator Side	0	300	%	300	1290	Generating power limit in AFE mode to grid.

6.5.3 AUTO START STOP

Table 29. Auto Start Stop

Code	Parameter	Min	Max	Unit	Default	ID	Description
P2.5.3.1	Start/Stop Function	0	1		0	1274	0 = Normal 1 = Auto
P2.5.3.2	Auto Stop Level	-100.0	100.0	%	-3.0	1099	
P2.5.3.4	Minimum Run Time	0	32000	ms	100	1281	
P2.5.3.5	Stop delay	0	32000	ms	1000	1282	

6.5.4 DC VOLTAGE

Table 30. DC Voltage

Code	Parameter	Min	Max	Unit	Default	ID	Description
P2.5.4.1	DC Voltage Supervision Limit	0	1100	V	600	1454	

6.6 DRIVE CONTROL PARAMETERS

Table 31. Drive control parameters

Code	Parameter	Min	Max	Unit	Default	ID	Description
P2.6.1	Switching frequency	3.6	Varies	kHz	3.6	601	Switching frequency
P2.6.2	Regen Options 1	0	65535		544	1463	This packed bit word is made for enabling/ disabling different control options for regeneration control.
P2.6.3	Regen Options 2	0	65535		0	1464	
P2.6.4	Start Up Delay	0.00	320.00	s	0.00	1500	Starting delay when run command is given. When you program different delays to the paralleled units, the units will start in sequence.
P2.6.5	Modulator Type	0	4		1	1516	0 = Hardware 1 = Software 1 2 = Software 2 3 = Software 3 4 = Software 4
P2.6.6	Control Options	0	65536		0	1798	Control word for activating special features.
P2.6.7	Operation Time	0	2 ³²		0	1855	Stored AFE Running time

6.7 CONTROL PARAMETERS

Table 32. Control parameters

Code	Parameter	Min	Max	Unit	Default	ID	Description
P2.6.8.1	Voltage Controller Kp	0	32000		200	1451	Gain for the DC voltage controller of the unit
P2.6.8.2	Voltage Controller Ti	0	1000	ms	50	1452	Integral time for the DC Voltage controller of the regenerative unit
P2.6.8.3	Active current Kp	0	4000		400	1455	Active current controller gain.
P2.6.8.4	Active current Ti	0.0	100.0	ms	1.5	1456	Active current controller integral time
P2.6.8.5	Sync Kp	0	32000		2000	1457	Synchronization gain
P2.6.8.6	Sync Ti	0	1000		50	1458	Synchronisation integral time (15 = 7ms).
P2.6.8.7	Modulator Index Limit	0	200	%	100	655	Lower value may improve current waveform, but causes the DC voltage to increase when the line voltage is high.
P2.6.8.8	Main Contactor Start Delay	0.00	10.00	s	0.40	1519	Start delay from Main Contactor Acknowledge
P2.6.8.9	Capacitor Size	0.0	100.0	%	6.3	1460	
P2.6.8.10	Inductor Size	0.0	100.0	%	15.5	1461	
P2.6.8.11	DynamicSupportKp	0	32000		0	1797	

6.8 FIELDBUS PARAMETERS

Table 33. Fieldbus parameters

Code	Parameter	Min	Max	Unit	Default	ID	Description
P2.7.1	Fieldbus data out 1 selection	0	65535		1104	1490	Choose monitoring data with parameter ID. Default Total Current.
P2.7.2	Fieldbus data out 2 selection	0	65535		1174	1491	Choose monitoring data with parameter ID. Warning Word 1.
P2.7.3	Fieldbus data out 3 selection	0	65535		1172	1492	Choose monitoring data with parameter ID. Fault Word 1.
P2.7.4	Fieldbus data out 4 selection	0	65535		1173	1493	Choose monitoring data with parameter ID. Fault Word 2.
P2.7.5	Fieldbus data out 5 selection	0	65535		56	1494	Choose monitoring data with parameter ID. Din Status 1.
P2.7.6	Fieldbus data out 6 selection	0	65535		57	1495	Choose monitoring data with parameter ID. Din Status 2.
P2.7.7	Fieldbus data out 7 selection	0	65535		0	1496	Choose monitoring data with parameter ID
P2.7.8	Fieldbus data out 8 selection	0	65535		1107	1497	Choose monitoring data with parameter ID. Supply Voltage.
P2.7.9	Fieldbus data in 1 selection	0	65535		0	876	Choose monitoring data with parameter ID
P2.7.10	Fieldbus data in 2 selection	0	65535		1161	877	Choose monitoring data with parameter ID. Aux Control Word.
P2.7.11	Fieldbus data in 3 selection	0	65535		0	878	Choose monitoring data with parameter ID
P2.7.12	Fieldbus data in 4 selection	0	65535		0	879	Choose monitoring data with parameter ID
P2.7.13	Fieldbus data in 5 selection	0	65535		0	880	Choose monitoring data with parameter ID
P2.7.14	Fieldbus data in 6 selection	0	65535		0	881	Choose monitoring data with parameter ID
P2.7.15	Fieldbus data in 7 selection	0	65535		0	882	Choose monitoring data with parameter ID
P2.7.16	Fieldbus data in 8 selection	0	65535		0	883	Choose monitoring data with parameter ID
P2.7.18	Control Slot Selector	0	8		0	1440	0 =All 4 =Slot D 5 =Slot E

6.9 PROTECTIONS

6.9.1 GENERAL

Table 34. Protections parameters

Code	Parameter	Min	Max	Unit	Default	ID	Description
2.8.1.1	Response to Thermistor fault	0	3		1	732	0=No response 1=Warning 2=Fault 3=Fault, DC OFF
2.8.1.2	Drive Over Temperature Fault Response	2	3		3	1517	0=No response 1=Warning 2=Fault 3=Fault, DC OFF
2.8.1.3	Over Voltage Fault Response	2	3		2	1507	2=Fault 3=Fault, DC OFF
2.8.1.4	Reserved					1990	
2.8.1.5	Input Filter Over Temperature Response	0	3		3	1505	0=No response 1=Warning 2=Fault 3=Fault, DC OFF
2.8.1.6	Max Charge Time	0.00	10.00	s	5.00	1522	Charging time limit when the drive charging options are used.
2.8.1.7	Main Contactor on Fault	0	1		0	1510	0 = Keep closed 1 = Open
2.8.1.8	Main Contactor Fault Delay	0.00	10.00	s	3.50	1521	Delay for (F64) MCC Open Fault. Defines the max delay time between the main contactor close command and the acknowledge signal.
2.8.1.9	Input Phase supervision Fault Response	0	3		2	1518	0=No response 1=Warning 2=Fault 3=Fault, DC OFF
2.8.1.10	Response to external fault	0	3		2	701	0=No response 1=Warning 2=Fault 3=Fault, DC OFF
2.8.1.11	Fan Fault Response	3	2		1	1524	0=No response 1=Warning 2=Fault 3=Fault, DC OFF
2.8.1.12	Input Filter Fan Fault Response	3	1		1	1509	0=No response 1=Warning 2=Fault 3=Fault, DC OFF
2.8.1.13	Cooling Flt. Delay	0	7	s	2	751	
P2.8.5	Reset Data Logger	0	1		0	1857	

6.9.2 PT-100

Table 35. PT-100

Code	Parameter	Min	Max	Unit	Default	ID	Description
P2.8.2.1	PT100 Inputs	0	6		0	1221	0= Not used 1= Analogue Input 1 2= PT100 input 1 3= PT100 input 1 & 2 4= PT100 input 1 & 2 & 3 5= PT100 input 2 & 3 6= PT100 input 3
P2.8.2.2	PT100 FaultResponse	0	3		2 / Fault	740	0=No response 1=Warning 2=Fault 3=Fault, DC OFF
P2.8.2.3	PT100 Warn.Limit	-30	200	°C	120	741	
P2.8.2.4	PT100 Fault Lim.	-30	200	°C	130	742	

6.9.3 EARTH FAULT

Table 36. Earth fault

Code	Parameter	Min	Max	Unit	Default	ID	Description
P2.8.3.1	EarthFlt Response	2	5		2 / Fault	1332	0=No response 1=Fault
P2.8.3.2	EarthFaultLevel	0	100	%	50	1333	
P2.8.3.3	Earth Fault Delay	0	30000	ms	800	774	

6.9.4 FIELDBUS

Table 37. Fieldbus

Code	Parameter	Min	Max	Unit	Default	ID	Description
P2.8.4.1	FB Communication fault response	0	2		1	733	0=No response 1=Warning 2=Fault
P2.8.4.2	FB Watchdog delay	0	5.00	s	2.00	1354	Watchdog fault delay for FB master. The function can be disabled if set to zero.

6.10 AUTO RESET PARAMETERS

Table 38. Auto reset parameters

Code	Parameter	Min	Max	Unit	Default	ID	Description
P2.9.1	Wait time	0.10	10.00	s	0.50	717	
P2.9.2	Trial time	0.00	60.00	s	30.00	718	
P2.9.3	Number of tries after overvoltage trip	0	10		0	721	
P2.9.4	Number of tries after over current trip	0	3		0	722	
P2.9.5	Number of tries after external fault trip	0	10		0	725	
P2.9.6	Fault Simulation	0	65535		0	1569	

6.11 DIN ID CONTROL

Table 39. DIN ID Control parameters

Code	Parameter	Min	Max	Unit	Default	Cust	ID	Description
P2.10.1	ID Control DIN	0.1	E.10		0.1		1570	Slot. Board input No.
P2.10.2	Controlled ID	0	10000		0		1571	Select ID that is controlled by digital input
P2.10.3	False value	-32000	32000		0		1572	Value when DI is low
P2.10.4	True value	-32000	32000		0		1573	Value when DI is high

6.12 KEYPAD CONTROL

Table 40. Keypad control parameters

Code	Parameter	Min	Max	Unit	Default	ID	Description
P3.1	Control place	2	0	2		1403	0=Fieldbus 1=I/O terminal 2=Keypad (Default)

6.13 SYSTEM MENU

For parameters and functions related to the general use of the AC drive, such as application and language selection, customised parameter sets or information about the hardware and software, see the VACON[®] NXS/P User Manual.

6.14 EXPANDER BOARDS

The M7 menu shows the expander and option boards attached to the control board and board-related information. For more information, see the VACON[®] NXS/P User Manual and VACON[®] I/O Option Board User Manual.

7. DESCRIPTION OF PARAMETERS

7.1 BASIC PARAMETERS

P2.1.1 RATED LINE VOLTAGE [# V] ID1201

This parameter sets the incoming line voltage for the regenerative drive. The maximum value is 690 V. Set this parameter to the nominal line voltage at the installation site.

P2.1.2 RATED LINE CURRENT [A] ID113

Rated current capacity of the supply or the transformer. May need to be set if AFE is oversized compared to LCL or feeding transformer capacity. For testing purposes, the feeding transformer should not be less than 20% of the unit nominal current or following breakers or fuses.

P2.1.3 RATED LINE POWER [kW] ID116

Set here the rated active power of the system.

P2.1.4 PARALLEL AFE ID1501

0 = Single AFE

1 = Parallel AFE

When selecting the parallel AFE DC, Drooping is set to 4.00% and modulation is synchronized to reduce circulating current if drives are in common DC bus.

7.2 REFERENCE HANDLING

P2.2.1 DC VOLTAGE REFERENCE [#,## %] ID1462

This parameter sets the DC Voltage reference in percentage of Nominal DC voltage (Nominal DC voltage = 1.35 * Supply voltage). The DC Voltage will be maintained at this level when the regenerative unit is running. For 500V units the maximum limit is 130% and for 690V units the maximum limit is 115%. The default value is 110%.

NOTE! DC-link voltage should not exceed the following values:

- 800V for 500V unit
- 1100V for 690V unit

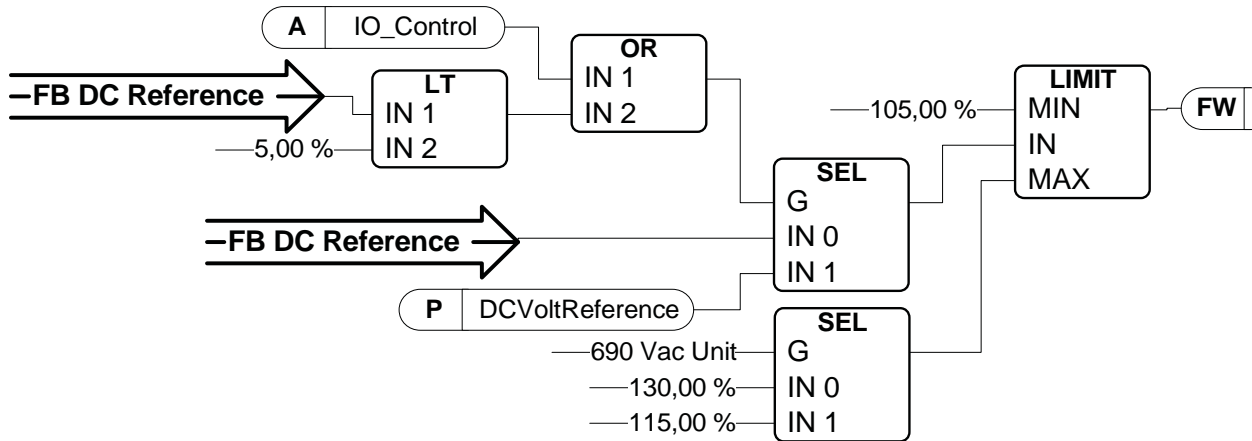

Figure 6. DC Voltage Reference Chain

P2.2.2 DC DROOP ID620

When AFEs are used in parallel in independent mode, drooping can be used for current balancing. The DCV voltage reference drooping is set as percentage of active current reference.

E.g. if drooping is 3.00% and the active current is 50% then the DC voltage reference is reduced by 1.5%. With drooping, the paralleled units can be balanced by adjusting the DCVoltReference to slightly different values.

P2.2.3 REACTIVE CURRENT REFERENCE SOURCE SELECTION ID1384

This parameter defines which source the Reactive current reference is taken from. If Panel is chosen then the reactive current reference is taken from parameter P2.2.4.

- 0 = Panel
- 1 = Analog Input 1
- 2 = Analog Input 2

If reference value is taken from either of the analog inputs, it is recommended to use bipolar analog input (-10V...10V, selected with a jumper).

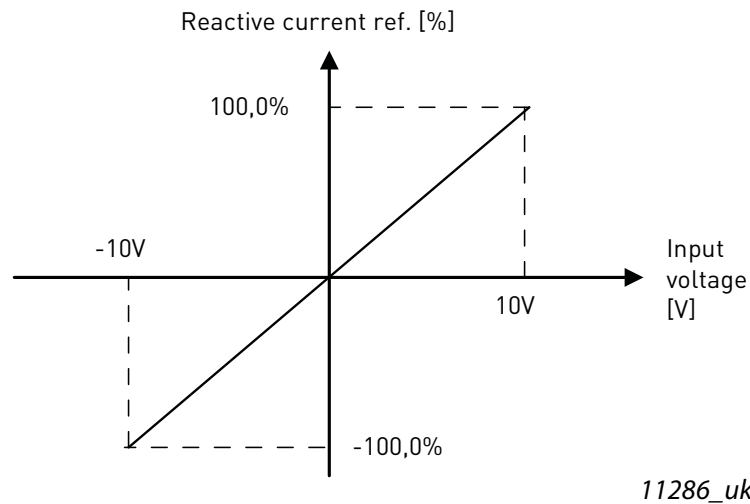

Figure 7. Analog input scaling (bipolar)

P2.2.4 REACTIVE CURRENT REFERENCE ID1459

This parameter sets the reference for the reactive current in percentage of the rated current. This can be used for power factor correction of AFE system or reactive power compensation.

A positive value makes inductive power to the grid

A negative value makes capacitive power to the grid.

Reactive current reference is taken from this parameter if panel has been chosen to be the source for Reactive current reference (P2.2.3 = 0).

7.3 INPUT SIGNALS

7.3.1 DIGITAL INPUTS

P2.3.1.1 RUN REQUEST ID1206

This parameter is used to choose the input used for the Run Request signal. When controlling the AFE from I/O this signal must be connected.

- 0 = Not used
- 1 = DIN1
- 2 = DIN2
- 3 = DIN3
- 4 = DIN4
- 5 = DIN5
- 6 = DIN6

P2.3.1.2 OPEN CONTACTOR ID1508

This parameter is used to choose the input for the Contactor Open signal. The signal is used to force the Relay Output RO2 (main contactor) open and stop modulating.

When this input is used to stop AFE and open a main contactor, the DC-link must be discharged and recharged to close the main contactor again and continue modulation (see Figure).

If the Force Main Contactor Open signal is not used, choose the option "0 = Not used".

- 0 = Not used
- 1 = DIN1
- 2 = DIN2
- 3 = DIN3
- 4 = DIN4
- 5 = DIN5
- 6 = DIN6
- 7 = DIN1 (inverted)
- 8 = DIN2 (inverted)
- 9 = DIN3 (inverted)
- 10 = DIN4 (inverted)
- 11 = DIN5 (inverted)
- 12 = DIN6 (inverted)

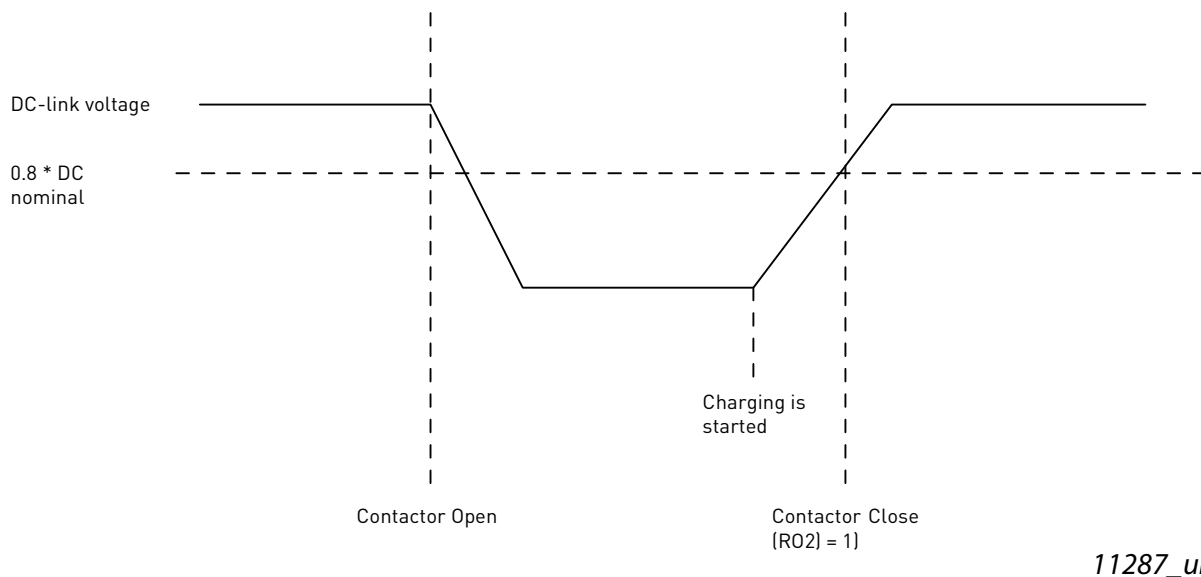

Figure 8. Contactor Open

11287_uk

P2.3.1.3 LCL TEMPERATURE MONITOR X52 ID1179 "LCL TEMP. X52"

This parameter defines if the drive monitors the status of the LCL over temperature switch signal. This wire is marked as "X52" when not using integrated DC/DC power supply.

This signal is normally used in cabinet installations. If the LCL Over temperature monitoring signal is not used in the system, choose the option "0 = Not used".

See parameter P2.3.1.2 for the list of values.

P2.3.1.4 MAIN CONTACTOR ACKNOWLEDGE ID1453

This parameter defines what input is used to monitor the status of the main contactor of the unit. If the feedback does not correspond the control signal within set time delay, the drive will indicate MCC Fault and will not be able to start until proper feedback is given.

See parameter P2.3.1.1 for the list of values.

NOTE! AFE needs feedback signal for correct operation. If feedback is not used there will be 3 second delay after closing command before drive can be started.

P2.3.1.5 LCL FAN MONITORING (X51) ID1178

This parameter defines if the drive monitors the status of the LCL Fan of the unit. When the monitoring function is used, the unit will give a warning if the LCL fan stops working and the LCL temperature reaches warning level.

Check from hardware if LCL is using X51 for fan monitoring or for LCL Temperature monitoring. If hardware uses X51 for fan monitoring, use this parameter. If it is used for LCL temperature monitoring, use P2.3.1.10 LCL Temperature Monitoring X51.

This signal is normally used in cabinet installations. If the status of the LCL fan is not monitored in the system, choose the option "0 = Not used".

See parameter P2.3.1.2 for the list of values.

P2.3.1.6 FAULT RESET ID1208

This parameter defines which digital input is used to reset faults.

See parameter P2.3.1.1 for the list of values.

P2.3.1.7 *EXTERNAL FAULT ID1214*

This parameter defines if the drive monitors the status of the External fault input. The response to the fault can be selected with the parameter P2.7.2.

See parameter P2.3.1.2 for the list of values.

P2.3.1.8 *RUN ENABLE ID1212*

This parameter defines which digital input is used for the external Run Enable signal. If Run Enable is used, the drive does not go to Ready state until the Run Enable goes high.

See parameter P2.3.1.1 for the list of values.

P2.3.1.9 *COOLING MONITOR ID750*

OK input from the cooling unit.

P2.3.1.10 *LCL TEMPERATURE MONITOR X51 ID750 "LCL TEMP. X51"*

This parameter defines if the drive monitors the status of the LCL over temperature switch signal from X51. This wire is marked as "X51" when not using integrated DC/DC power supply.

Check from hardware if LCL is using X51 for fan monitoring or for LCL Temperature monitoring. If hardware uses X51 for temperature monitoring, use this parameter. If it is used for LCL fan monitoring, use P2.3.1.5 LCL Fan Monitoring (X51).

This signal is normally used in cabinet installations. If LCL Over temperature monitoring signal is not used in the system, choose the option "0 = Not used".

See parameter P2.3.1.2 for the list of values.

7.3.2 ANALOGUE INPUTS

P2.3.2.1 ANALOG INPUT 1 MINIMUM ID1227

Minimum voltage or Current level at AI1.

0=0V / 0mA,

1=2V / 4mA

P2.3.2.2 ANALOG INPUT 1 FILTER TIME ID1228

Filter time in seconds for the filtering of signal connected to AI1. The range of time can be selected from 0.01 sec to 10.00 sec.

P2.3.2.3 ANALOG INPUT 2 MINIMUM ID1231

This parameter defines the minimum voltage or current on the AI2 terminal on OPT-A1 board.

0=0V / 0mA,

1=2V / 4mA

P2.3.2.4 ANALOGUE INPUT 2 FILTER TIME ID1232

Filter time in seconds for the filtering of signal connected to AI2. The range of time can be selected from 0.01 sec to 10.00 sec.

7.4 OUTPUT SIGNALS

7.4.1 DIGITAL OUTPUTS

P2.4.1.1 DO1 ID1216

This parameter defines which signal is connected to digital output 1.

0 = Digital output can be set from Fieldbus (Auxiliary Control Word, bit 13).

1 = Ready

2 = Running

3 = Fault

4 = No Fault

5 = Warning

6 = At Reference

7 = Regen Active (Unit is regenerating power)

8 = Charge DC

This output function is used to charge DC. This function can be used only when the Run Enable function is also in use. When run enable is HIGH and there are no active faults, the rising edge on the start command will start the DC charging and if charging is successful, the drive will go to Run State.

9 = Ready / Warning (blink).

10 = Over temperature fault (Drive over temperature or Fan not working)

11 = DC voltage above limit set with parameter P2.5.6.1

P2.4.1.2 DO2 ID1217

Select the signal for controlling the R01 of OPT-A2 option board.

See parameter P2.3.1.1 for the list of values.

P2.4.1.3 DO3, SLOT B: OUTPUT 2 (RO2) ID1218

This output control Main Contactor. Function cannot be changed.

P2.4.1.4-

P2.4.1.13 DO4- DO12 ID1385 - ID1429

These parameters are only visible when there are option cards with digital outputs installed in the AFE. If, for example, the option card OPT-B5 has been installed, the parameters for outputs DO3-DO5 become visible.

See parameter P2.3.1.1 for the list of values.

7.4.2 ANALOGUE OUTPUTS

NOTE! This menu is visible in the panel, if Analogue Input 1 is not used for PT100 measurement (P2.2.2.2 = 0).

P2.4.2.1 ANALOGUE OUTPUT 1 SIGNAL ID ID1233

Set the ID number of the signal to be connected to AO1. For example, to connect the DC-link voltage to Analog output 1, enter 1108 as the parameter value.

NOTE! If Analogue input has been chosen to be used for PT100 measurement (P2.2.2.2 > 0), the Analogue Output 1 is forced to 10mA level.

P2.4.2.2 ANALOGUE OUTPUT 1 OFFSET ID1234

This parameter defines the minimum voltage or current at Analog Output 1.

0 = 0V/0mA,

1 = 4mA

P2.4.2.3 ANALOGUE OUTPUT FILTER TIME ID1235

This parameter defines the filtering time of the analogue output signal.

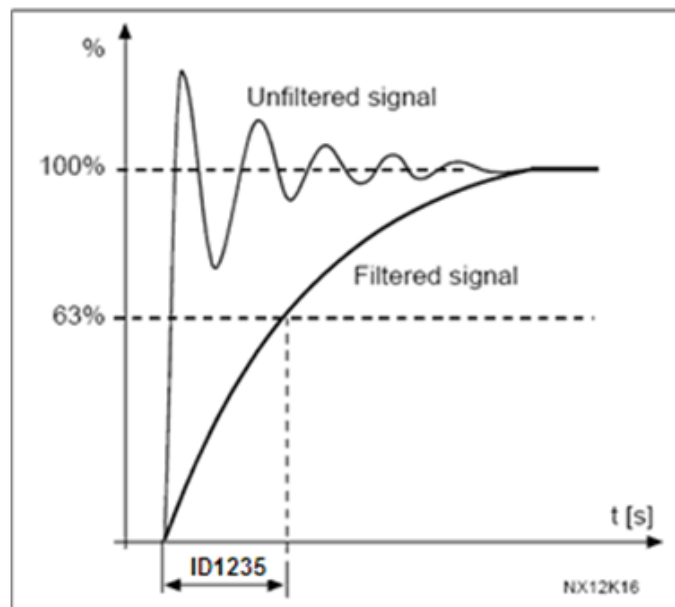

11288_uk

Figure 9. Analogue output filtering

P2.4.2.4 ANALOGUE OUTPUT MAXIMUM VALUE ID1236

Maximum value of a signal selected for AO1. This will correspond to +10V/20mA

P2.4.2.5 ANALOGUE OUTPUT MINIMUM VALUE ID1237

Minimum value of a signal selected for AO1. This will correspond to 0V/0mA or 2V/4mA depending on the offset parameter.

7.5 LIMIT SETTINGS

7.5.1 CURRENT LIMITS

P2.5.1.1 CURRENT LIMIT [A] ID107

Sets the current limit for the regenerative supply unit. Set this to correspond to the maximum required load or peak overload of the unit, bearing in mind that the load might consist of several motor drive units.

Maximum value $2 * I_H$ depends on the unit size.

7.5.2 POWER LIMITS

P2.5.2.1 POWER LIMIT MOTORING SIDE ID1289

This parameter sets the power limit for the motor side operation of the regenerative unit. 100.0% is equal to nominal power. Motoring Side operation means that the power flows from AC side to DC side.

P2.5.2.2 POWER LIMIT GENERATOR SIDE ID1290

This parameter sets the power limit for the generator side operation of the regenerative unit. 100.0% is equal to nominal power. The Generator Side operation means that the power flows from DC side to AC side. Setting a too low value may lead to overvoltage fault. In some cases, the power can not be fed to the ship grid and AFE is used for purely low harmonic requirements. In these cases, the BCU may be needed to consume the excess energy.

7.5.3 AUTO START STOP FUNCTION

P2.5.3.1 START FUNCTION

The parameter determines how the unit behaves when starting and stopping.

0 = Normal. Regenerative unit starts only with the run request.

1 = Auto. Regenerative unit will start automatically when the energy is to be fed back to the main network (regeneration) and stops when there is no regeneration.

P2.5.3.2 AUTO STOP LEVEL

Active current level when regeneration is stopped in Auto mode. When the active current value is higher than this value, regeneration will be stopped.

P2.5.3.3 MINIMUM RUN TIME ID1281 "MINIMUM RUN TIME"

This parameter defines the minimum running time when AFE starting is triggered by rising DC voltage. This parameter is applicable only when operating in Auto mode (P2.5.3.1 = 1).

P2.5.3.4 STOP DELAY ID1282 "STOP DELAY"

This parameter defines time period when internal DC reference is ramped to minimum before stopping the AFE, if no regenerative power is detected during this time. This parameter is applicable only when operating in Auto mode (P2.5.3.1 = 1).

7.5.4 DC VOLTAGE LIMIT PARAMETERS

P2.5.4.1 DC VOLTAGE SUPERVISION LIMIT ID1454

This parameter sets a supervision limit for the DC link voltage. If the voltage increases above this, this signal goes HIGH. This signal can be connected to digital output and it is copied to Main Status Word, Bit 10. This value does not limit the DC-link voltage but it can be used for monitoring purposes.

7.6 DRIVE CONTROL

P2.6.1 SWITCHING FREQUENCY ID601

The switching frequency of the IGBT bridge in kHz. Changing the default value may impact on the LCL filter operation.

P2.6.2 REGEN OPTIONS 1 ID1463

P2.6.3 REGEN OPTIONS 2 ID1464

This packed bit word is made for enabling/disabling different control options for regeneration control:

B0 = Disable DCV reduction with reactive reference generation with high line voltage.

B1 = Disable LCL reactive power compensation.

B5 = Disable all harmonic elimination compensation

This is active by default. When activated, this function will reduce a little the 5th and 7th harmonics. This will not reduce harmonics of the grid, only drive's own harmonics.

B8 = Enable double pulse synchronization

This option will generate two synchronization pulses instead of one. This may help synchronization on a weak grid.

B9 = Enable soft synchronization (\geq FI9)

This function enables zero crossing detection on FI9 and bigger units. When it is active and there is a connection to grid while drive is in stop state, the Supply Frequency is updated by detected frequency.

B12 = Enable floating DC reference. DC-link voltage will follow line voltage.

While run state drive can detect the Supply Voltage, if supply voltage changes, also the internal DC Reference is changed so that the DC Voltage is:

DC Voltage = Measured Supply Voltage * 1.35 * DC Reference

B13 = Enable use of D7 board for start synchronization.

When OPT-D7 board is installed this bit will activate synchronization by using voltage angle and frequency information from D7 board. Note that the phase order needs to be the same both in OPT-D7 and input phases. It is also recommended to keep frequency on positive side. Note that the frequency of the D7 board can be the same as the Supply Frequency but the phase order can still be wrong.

P2.6.4 START UP DELAY ID1500

This parameter defines a starting delay when the run command is given. When programming different delays to the paralleled units, the units will start in sequence. This is needed in parallel units so that synchronization does not happen simultaneously with all drives. Simultaneous starting may lead to failed synchronization. The recommended value between the drives is 500 ms.

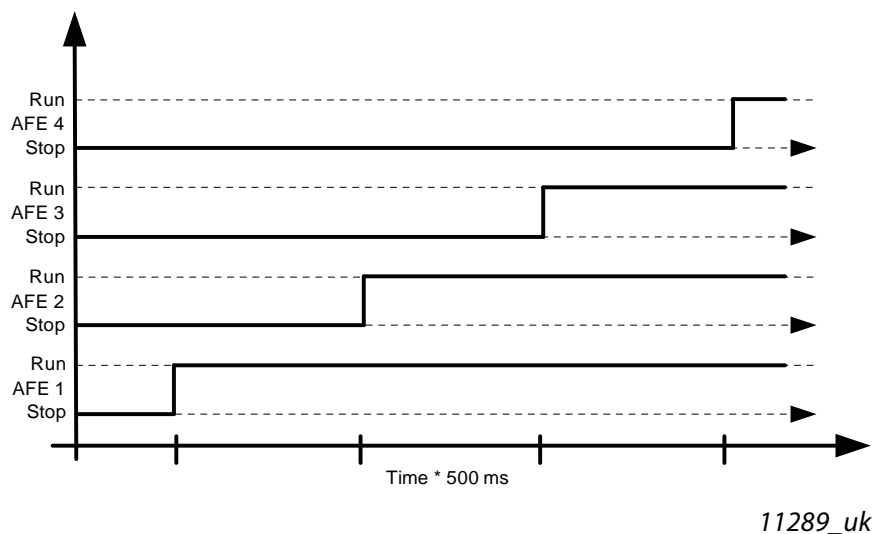

Figure 10. Start up delay

P2.6.5 MODULATOR TYPE ID1516

This parameter is for changing the modulator type. With the ASIC (HW) modulator the current distortion is lower, but losses are higher compared to a software modulator. It is recommended to use a software modulator.

0 = Hardware modulator: ASIC modulator with classic third harmonic injection. Spectrum is slightly better compared to Software 1 modulator.

1 = Software modulator 1: Symmetric vector modulator with symmetrical zero vectors. Current distortion is less than with software modulator 2 if boosting is used.

2 = Software modulator 2: Symmetric BusClamb in which one switch always conducts 60 degrees either to negative or positive DC-rail. Switching losses are reduced without different heating of upper and lower switches. Spectrum is narrow. Not recommended for parallel units.

3 = Software modulator 3: Unsymmetric BusClamb in which one switch always conducts 120 degrees to negative DC-rail to reduce switching losses. Drawback is that upper and lower switches are unevenly loaded and spectrum is wide. Not recommended for parallel units.

4 = Software modulator 4: Pure sine wave, sinusoidal modulator without harmonic injection. Dedicated to be used in back-to-back test benches etc. to avoid circulating third harmonic current. Drawback is that required DC voltage is 15% higher compared to other modulator types.

P2.6.6 CONTROL OPTIONS ID1798

B05 = +32 = Use ENC C1 as fast RunEnable.

B06 = +64 = Enable Fan Fault while no DC Voltage.

B12 = +4096 = Disable Dead Time Hw Compensation.

B13 = +8192 = Enable MCB Fault autoreset.

B14 = +16384 = Enable MCB Fault when feedback is lost in Run state.

P2.6.6 OPERATION TIME ID1855

Stored Operation Time. When application is reloaded, the operation hours will go to zero if this parameter is not updated.

Monitoring signal is in hours with two decimals.

Parameter is in the following format:

xx (Years) XX (Months) XX (Days) XX (Hours) XX Minutes

1211292359 -> 12 years, 11 months, 29 days, 23 hours and 59 minutes.

7.6.1 DRIVE CONTROL**P2.6.8.1 VOLTAGE CONTROLLER Kp ID1451**

This parameter sets the gain for the DC link PI voltage controller.

P2.6.8.2 VOLTAGE CONTROLLER Ti ID1452

This parameter sets the time constant in ms of the DC link PI controller.

P2.6.8.3 ACTIVE CURRENT CONTROLLER Kp ID1455

This parameter sets the gain of the controller for the active current of the regenerative unit.

P2.6.8.4 ACTIVE CURRENT CONTROLLER Ti ID1456

This parameter sets the time constant of the controller for the active current of the regenerative unit (15 equals 1.5ms).

P2.6.8.5 SYNC Kp ID1457

This parameter sets the gain of the synchronisation controller used to synchronise the switching to the supply.

P2.6.8.6 SYNC Ti ID1458

This parameter sets the time constant of the controller used to synchronise the switching to the supply (15 equals 7ms).

P2.6.8.7 MODULATOR INDEX LIMIT ID655

This parameter can be used to control how the drive modulates the output voltage. The lower value may improve the current waveform, but causes the DC voltage to increase when the line voltage is high.

P2.6.8.8 MAIN CONTACTOR START DELAY ID1519

Main contactor On delay. The delay from the Main contactor acknowledge signal to the modulation start. If the main contactor feedback function is bypassed, this time is internally set to 2 seconds.

P2.6.8.9 CAPACITOR SIZE ID1460

This parameter defines the reactive current going to the LCL filter capacitor. It compensates the LCL effect to the reactive current by adjusting the reactive current reference internally. The inductor size is also added to compensation. If set correctly, the power factor on the grid side will be 1.

P2.6.8.10 *INDUCTOR SIZE ID1461*

This parameter defines voltage losses in percentage of the nominal voltage at 100% active current. This value is internally added to the reactive current reference thus giving power factor 1 on the grid side, if set correctly together with Capacitor Size. The transformer and feeding cables can be compensated by increasing this value.

P2.6.8.11 *DYNAMIC SUPPORT KP ID1797*

7.7 FIELD BUS PARAMETERS

P2.7.1 -

P2.7.8 FIELD BUS DATA OUT 1-8 SELECTION ID1490-ID1497

Using these parameters, you can monitor any monitoring or parameter value from the fieldbus. Enter the ID number of the item you wish to monitor for the value of these parameters.

P2.7.9 -

P2.7.16 FIELD BUS DATA IN 1-8 SELECTION ID876-ID883

Using these parameters, you can control any parameter from the fieldbus. Enter the ID number of the item you wish to control for the value of these parameters.

P2.7.17 CONTROL SLOT SELECTOR ID1440 "CONTROL SLOT SEL."

This parameter defines which slot is used as the main control place when two fieldbus boards have been installed in the drive. When values 6 or 7 are selected, the drive uses the Fast Profibus profile. When the Fast Profibus profile is used, the type 'B' boards or other C type boards cannot be used.

NOTE: Set first the Slave Address and the PPO type before selecting the Fast Profibus mode.

0 = All slots

4 = Slot D

5 = Slot E

6 = Slot D, Fast Profibus support

7 = Slot E, Fast Profibus support

7.8 PROTECTIONS

P2.8.1.1 RESPONSE TO THERMISTOR FAULT ID732

0 = No response

1 = Warning

2 = Fault (the drive will stop modulation leaving main contactor closed)

3 = Fault, DC off (main contactor open)

Setting the parameter to 0 will deactivate the protection.

P2.8.1.2 RESPONSE TO DRIVE OVERTEMPERATURE FAULT ID1517

2 = Fault

3 = Fault, DC off (main contactor open)

For the warning and tripping limits, see the User manual of the AC drive. Note that air cooled and liquid cooled limits are different.

P2.8.1.3 RESPONSE TO OVERVOLTAGE FAULT ID1507

2 = Fault

3 = Fault, DC off (main contactor open)

P2.8.1.4 RESERVED ID1990

P2.8.1.5 RESPONSE TO INPUT FILTER OVER TEMPERATURE ID1505

This parameter defines a response to the LCL over temperature fault. The LCL fault is monitored through the digital input defined in group G2.3.1.

0 = No response

1 = Warning

2 = Fault (the drive will stop modulation leaving the main contactor closed)

3 = Fault, DC off (main contactor open)

P2.8.1.6 MAX CHARGE TIME ID1522

When the drive charging options is used, this parameter defines the maximum time limit for charging.

P2.8.1.7 MAIN CONTACTOR ON FAULT ID1510

This parameter defines a response to ANY fault that occurs in the AFE.

0 = Main Contactor is kept closed in case of fault

- Faults that have been defined to open the Main Contactor are still active.

1 = Any fault in the drive will open the Main Contactor.

NOTE! F1 over current, F31 IGBT HW and F41 IGBT SW will always open Main Circuit Breaker (MCB).

P2.8.1.8 MAIN CONTACTOR OPEN FAULT DELAY ID1521

Delay for Main contactor open fault. The delay between the main contactor control relay close command and the main contactor acknowledge signal. If the acknowledge signal is not received within this time, a fault F64 will be triggered.

P2.8.1.9 RESPONSE TO INPUT PHASE SUPERVISION ID1518

- 0 = No response
- 1 = Warning
- 2 = Fault
- 3 = Fault, DC off (main contactor open)

The input phase supervision ensures that the input phases of the AC drive has an approximately equal current.

P2.8.1.10 RESPONSE TO EXTERNAL FAULT ID701

This parameter defines a response to external fault. If the drive monitors the state of the external fault input (value of P2.2.1.7 > 0) and a fault occurs the drive can be set to respond to the fault.

- 0 = No response
- 1 = Warning
- 2 = Fault (the drive will stop modulation leaving main contactor closed)
- 3 = Fault, DC off (main contactor open)

P2.8.1.11 FAN FAULT RESPONSE ID1524

This parameter defines a response for the Fan fault.

Drive Fan and LCL inverter controlled fan

- 1 = Warning
- 2 = Fault
- 3 = Fault, DC off (main contactor open)

P2.8.1.12 INPUT FILTER FAN FAULT RESPONSE ID1509

This parameter defines a response to the Input Filter Fan fault. If the drive monitors the state of the input filter fan (value of P2.2.1.5 > 0) and a fault occurs the drive can be set to respond to the fault.

- 0 = No response
- 1 = Warning
- 2 = Fault (the drive will stop modulation leaving main contactor closed)

P2.8.1.13 COOLINGFLT.DELAY

Protection for liquid cooled units. An external sensor is connected to the drive (DI: Cooling Monitor) to indicate if cooling liquid is circulating. If the drive is in Stop state this is only a warning. In Run state, the drive will issue a fault with a coast stop.

This parameter defines the delay after which the drive goes to fault state when 'Cooling OK' signal is missing.

7.8.1 PT100 TEMPERATURE**P2.8.2.1 PT100 INPUT SELECTION ID1221**

Selects the analogue input to be used for the temperature measurement using a PT100 sensor.

If the Analogue input has been used for the PT100 measurement, the Analogue Output 1 is forced to 10mA level and it is used as a power supply for the PT100 sensor. The connection has been illustrated in Figure .

0 = Not used

1 = AI1

2-6 = Measurements are taken from PT-100 board

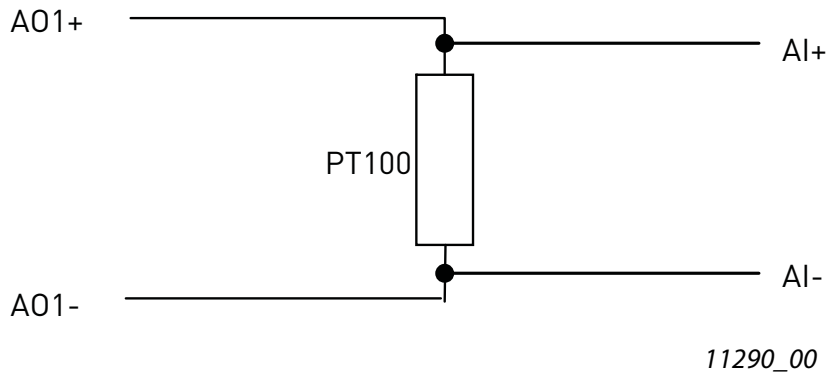

Figure 11. PT100 connection, with Analogue input configuration

P2.8.2.2 **RESPONSE TO PT100 FAULT ID740**

0 = No response

1 = Warning

2 = Fault

3 = Fault, DC off (main contactor open)

Setting the parameter to 0 will deactivate the protection.

P2.8.2.3 **PT100 WARNING LIMIT ID741**

Set here the limit at which the PT100 warning will be activated.

P2.8.2.4 **PT100 FAULT LIMIT ID742**

Set here the limit at which the PT100 fault will be activated.

7.8.2 **EARTH FAULT**

The earth fault protection ensures that the sum of the output phase currents is zero. The overcurrent protection is always working and protects the AC drive from earth faults with high currents.

P2.8.3.1 **RESPONSE TO EARTH FAULT ID1332**

The earth fault protection ensures that the sum of the phase currents is zero. The overcurrent protection is always working and protects the AC drive from earth faults with high currents.

0 = No response

1 = Fault

P2.8.3.2 **EARTH FAULT CURRENT ID1333**

Max. level of Earth current in percentage of unit current.

P2.8.3.3 **EARTH FAULT DELAY ID774 "EARTH FAULTDELAY"**

Delay before Earth fault is generated.

7.8.3 **FIELDBUS**

P2.8.4.1 RESPONSE TO FIELDBUS FAULT ID733 "FBCOMM.FAULTRESP"

Set here the response for a fieldbus fault if the active control place is fieldbus. For more information, see the respective Fieldbus Board Manual.

0 = No response

1 = Warning

2 = Fault

P2.8.4.1 FIELDBUS WATCH DOG DELAY ID1354

Defines the delay after which a fault is generated when the watch dog pulse is missing from fieldbus. Set the time to zero to disable watchdog monitoring.

P2.8.5 DATA LOGGER RESET ID1857

Parameter to reset the data logger to its defaults. We recommend you to reset settings after the initial commissioning if you changed them.

7.9 AUTO RESTART

P2.9.1 WAIT TIME ID717

Defines the time for the attempted fault reset after the fault trigger has passed. The wait time count starts only when the cause of the fault has been removed. E.g. external fault digital input is not in fault state.

P2.9.2 TRIAL TIME ID718

If the fault trigger appears more often than defined by parameters P2.9.3 to P2.9.5 inside the trial time, a permanent fault is generated.

P2.9.3 NUMBER OF TRIES AFTER OVERVOLTAGE TRIP ID721

This parameter determines how many automatic restarts can be made during the trial time set by parameter P2.9.2 after an overvoltage trip.

0 = No automatic restart after overvoltage fault trip.

>0 = Number of automatic restarts after overvoltage fault trip. The fault is reset and the drive is started automatically after the DC-link voltage has returned to the normal level.

P2.9.4 NUMBER OF TRIES AFTER OVERCURRENT TRIP ID722

NOTE! IGBT temp fault also included.

This parameter determines how many automatic restarts can be made during the trial time set by the parameter P2.9.2.

0 = No automatic restart after overcurrent fault trip

>0 = Number of automatic restarts after overcurrent trip and IGBT temperature faults.

P2.9.5 NUMBER OF TRIES AFTER EXTERNAL FAULT TRIP ID725

This parameter determines how many automatic restarts can be made during the trial time set by the parameter P2.9.2.

0 = No automatic restart after External fault trip

>0 = Number of automatic restarts after External fault trip

P2.9.6 FAULT SIMULATION ID1569 "FAULT SIMULATION"

With this parameter it is possible to simulate different faults without actually causing e.g. overcurrent fault situation.

B00 = +1 = Simulates overcurrent fault (F1)

B01 = +2 = Simulates overvoltage fault (F2)

B02 = +4 = Simulates undervoltage fault (F9)

B03 = +8 = Simulates output phase supervision fault (F11)

B04 = +16 = Simulates earth fault (F3)

B05 = +32 = Simulates system fault (F8)

B06 = +64 = Reserved

B07 = +128 = Simulates over temperature warning (W14)

B08 = +256 = Simulates over temperature fault (F14)

7.10 DIN ID CONTROL

This function is used to control any parameter between two different values with a digital input. Different values are given for DI 'low' and DI 'high'.

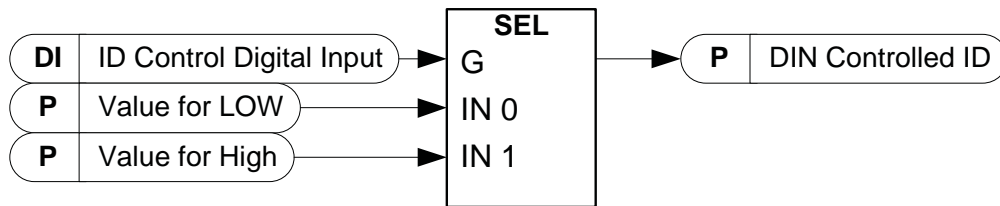

11291_uk

Figure 12. DIN ID control

P2.10.1 ID CONTROL DIGITAL INPUT ID1570 "ID CONTROL DIN"

Select the digital input to be used for controlling the parameter selected by P2.10.2.

P2.10.2 DIN CONTROLLED ID ID1571 "CONTROLLED ID"

Select the parameter ID controlled by P2.10.1.

P2.10.3 VALUE FOR LOW DIGITAL INPUT (FALSE) ID1572 "FALSE VALUE"

Set here the controlled parameter value when the digital input (P2.10.1) is LOW for the parameter selected by P2.10.2. The function does not recognize decimals. Give, therefore, e.g. 10.00 Hz as '1000'.

P2.10.4 VALUE FOR HIGH DIGITAL INPUT (TRUE) ID1573 "TRUE VALUE"

Set here the controlled parameter value when the digital input (P2.10.1) is HIGH for the parameter selected by P2.10.2. The function does not recognize decimals. Give, therefore, e.g. 10.00 Hz as '1000'.

7.11 KEYPAD CONTROL

P3.1 CONTROL PLACE ID1403

The active control place can be changed with this parameter.

NOTE! Keypad is the default control place.

- 0 = Fieldbus
- 1 = I/O terminal
- 2 = Keypad (Default)

8. FIELDBUS PROFILE FOR VACON® REGENERATIVE DRIVE

This chapter describes the fieldbus profile for the AFE application. The tables below give details for bypass operation of such fieldbus boards that natively support bypass type of operation or can be parameterized to operate in bypass mode. DeviceNet is an exception, see tables specified for DeviceNet fieldbus board.

8.1 SIGNALS FROM OVERRIDING SYSTEM TO VACON® REGENERATIVE DRIVE

Table 41. Signals from overriding system

Profibus Data Name	Signal Name	Min	Max	FB Scale	Scaling Description
Control Word	Main Control Word				See bitwise description below
Reference	Voltage Reference	105	130 for 500V 115 for 690V		DC Voltage reference as a percentage of the nominal DC voltage when the unit is controlled from Fieldbus.
Process Data IN1					Reserved for future use.
Process Data IN2	Aux. Control Word 1				See bitwise description below
Process Data IN3					Reserved for future use.
Process Data IN4					Reserved for future use.
Process Data IN5					Reserved for future use.
Process Data IN6					Reserved for future use.
Process Data IN7					Reserved for future use.
Process Data IN8					Reserved for future use.

8.2 SIGNALS FROM VACON® DRIVE TO OVERRIDING SYSTEM

Table 42. Signals to overriding system

Profibus Data Name	Signal Name	FB Scale	Scaling Description
Main Status Word	Main Status Word		See bitwise description below
DC Voltage	DC Voltage	1=1V	DC Voltage in Volts
ProcessDataOut1	Total current	10=1A	Total Current
ProcessDataOut2	Alarm Word 1		See bitwise description below
ProcessDataOut3	Fault Word1		See bitwise description below
ProcessDataOut4	Fault Word2		See bitwise description below
ProcessDataOut5	Digital Input Status Word 1		See bitwise description below
ProcessDataOut6	Digital Input Status Word 2		See bitwise description below
ProcessDataOut7			Reserved for future use.
ProcessDataOut8	Supply Voltage	1=1V	Supply voltage in volts

8.3 MAIN CONTROL WORD

Table 43. Main Control Word ID1160

FALSE		TRUE
B00	DC charge Contactor close	0 = No Action 1 = Close DC charge contactor (can be used to control external charge circuit by connecting this signal to digital output, see group G2.4.1).
B01	OFF2 =Stop	0 =stop Active. Regenerative control is stopped. 1 =stop not active
B02		Reserved for future use.
B03	Run	0 = Regeneration control not active 1 = Regeneration control active
B04		Reserved for future use.
B05		Reserved for future use.
B06		Reserved for future use.
B07	Reset	0>1 Reset fault.
B08	Set DC Voltage Ref 1	DC Voltage Reference 1 = 115% of Nominal DCVlt-age.
B09	Set DC Voltage Ref 2	DC Voltage Reference 2 = 120% of Nominal DCVlt-age.
B10	Fieldbus Control	0 = No control from fieldbus 1 =Control from fieldbus
B11	Watchdog	0>1>0>1...1 sec square wave clock. This is used to check data communication between fieldbus master and the drive. Used to generate FB Comm. Fault. This monitoring can be switched off by setting P2.8.4.2 FB Watchdog Delay=0. The drive's internal communication monitoring is still active at this time.
B12		Reserved for future use.
B13		Reserved for future use.
B14		Reserved for future use.
B15		Reserved for future use.

B00: FALSE = No Action, TRUE = PreCharge DC

ON: Drive will start precharge if the function is activated by digital output and the control place is fieldbus.

When control place is not fieldbus, precharging is started from the normal start command.

For fieldbus B10 also needs to be active.

B01: FALSE = Coast stop (OFF 2), TRUE = ON 2

Coast Stop: Drive will make coasting stop.

ON 2: No Coast Stop command

B03: FALSE = Stop Request, TRUE = Start Request

Stop Request: Drive will stop.

Start Request: Start Command to the drive.

B07: FALSE = No significance, TRUE = Fault Acknowledge

Fault Acknowledge: The group signal is acknowledged with a positive edge.

8.4 FB REFERENCE CONTROL

When the DC reference from fieldbus is below 5 (FW: FBSpeedReference < 5), the reference from fieldbus is ignored. When the reference is below 105 (FW: FBSpeedReference < 105), the reference is limited to 105.00%. The FB Reference cannot be activated when the control place is IO Control. MainControlWord B8 and B9 reference function is activated by Aux Control Word B12. MainControlWord B8 and B9 reference function is activated by Aux Control Word B12.

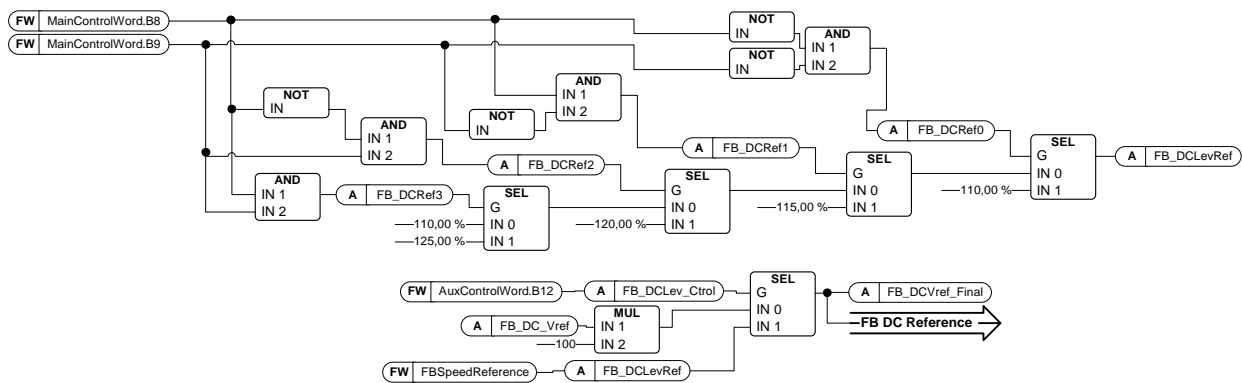

11292_00

Figure 13. FB DC Reference Chain

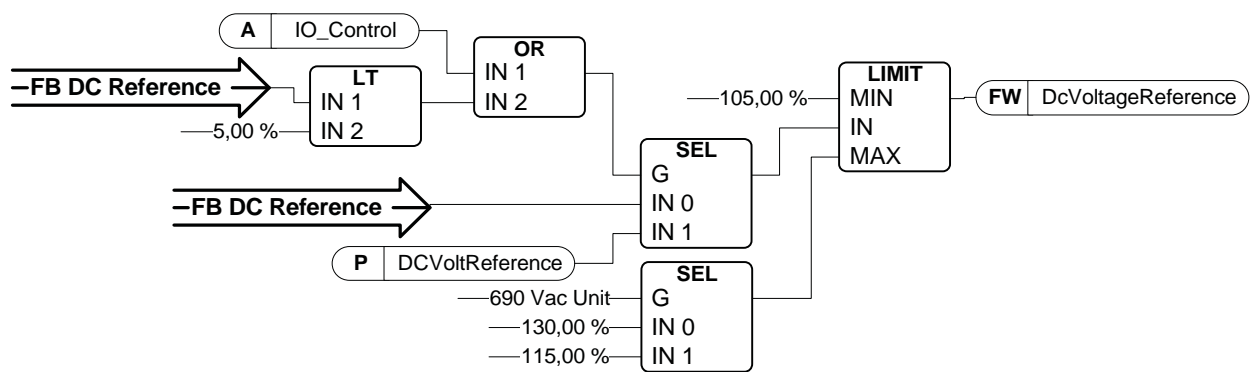

11285_00

Figure 14. DC Voltage Reference Chain

B08: FALSE = No Function, TRUE = DC Ref 1

B09: FALSE = No Function, TRUE = DC Ref 2

Table 44. FB DC Ref Bit control

DC Ref	110.00%	115.00%	120.00%	125.00%
B08	FALSE	TRUE	FALSE	TRUE
B09	FALSE	FALSE	TRUE	TRUE

B10: FALSE = FB Control disabled TRUE = FB Control Enabled

FB Control Disabled: Drive will not follow main control word from Fieldbus. If removed while running, the drive will make a coasting stop.

FB Control Enabled: Drive follows control word from fieldbus

B11: FALSE = FB WD Pulse Low, TRUE = FB WD Pulse High

Watch dog pulse: This pulse is used to monitor that PLC is alive. If pulse is missing, the drive will go to fault state. This function is activated by P2.8.4.2 FB WD Delay. When value is zero, the pulse is not monitored.

8.5 MAIN CONTROL WORD (IN DEVICENET)

NOTE: When using DeviceNet option board, use the following Control Word. (See also Auxiliary Control Word)

Table 45. Main Control Word (in DeviceNet)

	FALSE	TRUE
b0	Run	0= Regeneration control not active 1= Regeneration control active
b1		
b2	Reset	0>1 Reset fault.
b3		
b4		
b5	Fieldbus Control	0= No control from fieldbus 1=Control from fieldbus
b6		
b7		
b8		
b9		
b10		
b11		
b12		
b13		
b14		
b15		

B00: FALSE = Stop Request, TRUE = Start Request

Stop Request: Drive will stop.

Start Request: Start Command to the drive.

B02: FALSE = No significance, TRUE = Fault Acknowledge

Fault Acknowledge: The group signal is acknowledged with a positive edge.

B05: FALSE = FB Control disabled TRUE = FB Control Enabled

FB Control Disabled: Drive will not follow main control word from Fieldbus. If removed when running, the drive will make a coasting stop.

FB Control Enabled: Drive follows control word from fieldbus

8.6 MAIN STATUS WORD

Table 46. Main Status Word

	FALSE	TRUE
b0	Ready On	0=Drive not ready to switch on 1=Drive ready to switch Main Contactor ON
b1	Ready Run	0=Drive not ready to run 1=Drive ready and Main Contactor is ON
b2	Running	0=Drive not running 1=Drive running with Regenerative control ON
b3	Fault	0=No active fault 1=Fault is active
b4	Off2 Status	0= Stop command Active. Regenerative control is stopped. 1= stop command not active
b5		Reserved for future use.
b6		Reserved for future use.
b7	Warning	0=No warning 1=Warning active
b8	At Reference	0= DC Voltage Ref and Act DC Voltage are not same.
b9	Fieldbus Control Active	0=Fieldbus control not active 1=Fieldbus control active
b10	Above Limit	0= DC Voltage is below the level specified by P2.5.6.1 1=The DC Voltage is above the specified level by P2.5.6.1
b11		Reserved for future use.
b12		Reserved for future use.
b13		Reserved for future use.
b14		Reserved for future use.
b15	Watchdog	Same as received on bit 11 of the main control word.

B00: FALSE = Not Ready to Switch On, TRUE = Ready to Switch On

Not Ready to Switch On:

Ready to Switch On:

B01: FALSE = Not Ready To Operate, TRUE = Ready To Operate

Not Ready To Operate:

Ready To Operate:

B02: FALSE = Drive is not operating, TRUE = Drive is operational

Drive is not operating: Drive is not run state (modulating)

Drive is operational: Drive is in run state and modulating.

B03: FALSE = No Fault, TRUE = Fault Present

No Fault: Drive is not on fault state.

Fault Present: Drive is in fault state.

B04: FALSE = Coast Stop Activated, TRUE = Coast Stop Not Activated

Coast Stop Activated: "Coast Stop (OFF 2)" command is present.

Coast Stop Not Activated: Coast stop command is not active.

B07: FALSE = No Warning, TRUE = Warning Present

No Warning: There is no warning or the warning has disappeared again.

Warning Present: Drive still works; warning in the service/maintenance parameter; no acknowledgement.

B08: FALSE = DC Voltage out of tolerance TRUE = DC Voltage within tolerance

DC Error Out Of Tolerance Range:

DC Error Within Tolerance Range:

B09: FALSE = No Control Requested, TRUE = Control Requested

No Control Requested: Control by the automation system is not possible, only possible at the device or by another interface.

Control Requested: The automation system is requested to assume control.

B10: FALSE = DC Not Reached, TRUE = DC Reached Or Exceeded

f Or n Not Reached: DC is below P2.5.6.1 DC Voltage Supervision Limit

f Or n Reached Or Exceeded: DC is above P2.5.6.1 DC Voltage Supervision Limit

B15: FALSE = FB WD Feedback Low, TRUE = FB WD Feedback High

FB WD Feedback: FB Control Word B11 is echoed back to the Fieldbus. Can be used to monitor the communication status from the drive.

8.7 FAULT WORD 1

Table 47. Fault Word 1

Fault		Comment
b0	Over Current	F1
b1	Overvoltage	F2
b2	Under voltage	F9
b3	Not used	
b4	Earth Fault	F3
b5	Not used	
b6	Unit Over Temperature	F14
b7	Over Temperature	F59, F56, F71
b8	Input Phase loss	F11
b9	Not used	
b10	Device Fault	F37, F38, F39, F40, F44, F45
b11	Not used	
b12	Not used	
b13	Not used	
b14	Not used	
b15	Not used	

8.8 FAULT WORD 2

Table 48. Fault Word 2

FALSE		TRUE
b0	Not used	
b1	Charging Switch Fault	F5
b2	Not used	
b3	Drive Hardware fault	F4, F7
b4	Under Temperature	F13
b5	EPROM or Checksum fault	F22
b6	External fault	F51
b7	Not used	
b8	Internal Communication	F25
b9	IGBT Temperature	F31, F41
b10	Not used	
b11	Cooling fan	F32, F70
b12	Application fault	F35
b13	Drive Internal fault	F33, F36, F8, F26
b14	Main Switch open	F64
b15	Not used	

8.9 WARNING WORD 1

Table 49. Warning Word 1

FALSE		TRUE
b0	Not used	
b1	Temperature protection	W29: Thermistor warning, W56: FPT100 warning or W71: LCL over temperature warning
b2		
b3	Supply Phase Warning	W11
b4	Not used	
b5	Not used	
b6	Not used	
b7	Drive over temperature	W14
b8	Not used	
b9	Not used	
b10	Fan Warning	W32: Fan Cooling W70: LCL Fan monitor warning
b11	Not used	
b12	Not used	
b13	Not used	
b14	Not used	
b15	Not used	

8.10 AUXILIARY CONTROL WORD

Table 50. Auxiliary Control Word

FALSE		TRUE
b0		Reserved for future use.
b1		Reserved for future use.
b2		Reserved for future use.
b3		Reserved for future use.
b4		Reserved for future use.
b5		Reserved for future use.
b6		Reserved for future use.
b7		Reserved for future use.
b8		Reserved for future use.
b9		Reserved for future use.
b10		Reserved for future use.
b11		Reserved for future use.
b12	Enable DC Level control from MCW	0 = DC Voltage Level control from Main Control Word (MCW) is not active and DC Voltage reference is from fieldbus data (reference value). 1 = DC Voltage Level control from MCW is enabled
b13	DO control	This signal can be connected to digital output with group G2.4.1 parameters
b14		Reserved for future use.
b15		Reserved for future use.

B12: FALSE = DC Ref FB Speed Ref, TRUE = DC Ref controlled by Bits

DC Ref FB Speed Ref: Fieldbus reference is given by FBSpeedReference process data. Reference scaling 110 = 110.00% DC Reference.

DC Ref Controlled By Bits: DC Reference is controlled by main control word bits B08 and B09.

B13: FALSE = DO Control Low, TRUE = DO Control High

DO Control Low: DO is controlled Low.

DO Control High: DO is controlled High

8.11 AUXILIARY CONTROL WORD (IN DEVICENET)

Table 51. Auxiliary Control Word (in DeviceNet)

FALSE		TRUE
b0	DC charge Contactor close	0 = No Action 1 = Close DC charge contactor (can be used to control external charge circuit by connecting this signal to digital output, see group G2.4.1).
b1	OFF2 =Stop	0 =stop Active. Regenerative control is stopped. 1 =stop not active
b2	Set DC Voltage Ref 1	DC Voltage Reference 1 = 115% of Nominal DCVoltage.
b3	Set DC Voltage Ref 2	DC Voltage Reference 2 = 120% of Nominal DCVoltage.
b4	Watchdog	0>1>0>1...1 sec square wave clock. This is used to check the data communication between fieldbus master and the drive. Used to generate FB Comm. Fault. This monitoring can be switched off by setting P2.8.4.2 FB Watchdog Delay=0. The drive's internal communication monitoring is still active at this time.
b5		Reserved for future use.
b6		Reserved for future use.
b7		Reserved for future use.
b8		Reserved for future use.
b9		Reserved for future use.
b10		Reserved for future use.
b11		Reserved for future use.
b12	Enable DC Level control from MCW	0 = DC Voltage Level control from Main Control Word (MCW) is not active and DC Voltage reference is from fieldbus data (reference value). 1 = DC Voltage Level control from MCW is enabled
b13	DO control	This signal can be connected to digital output with group 2.4.1 parameters.
b14		Reserved for future use.
b15		Reserved for future use.

B00: FALSE = No Action, TRUE = PreCharge DC

ON: Drive will start precharge if the function is activated by digital output and the control place is fieldbus.

When control place is not fieldbus precharging is started from normal start command.

For fieldbus B10 also needs to be active.

B01: FALSE = Coast stop (OFF 2), TRUE = ON 2

Coast Stop: Drive will make coasting stop.

ON 2: No Coast Stop command

8.12 FB REFERENCE CONTROL (DEVICE NET)

When the DC reference from fieldbus is below 5 (FW: FBSpeedReference < 5), the reference from fieldbus is ignored. When the reference is below 105 (FW: FBSpeedReference < 105), the reference is limited to 105.00%. FB Reference cannot be activated when the control place is IO Control. MainControlWord B8 and B9 reference function is activated by Aux Control Word B12.

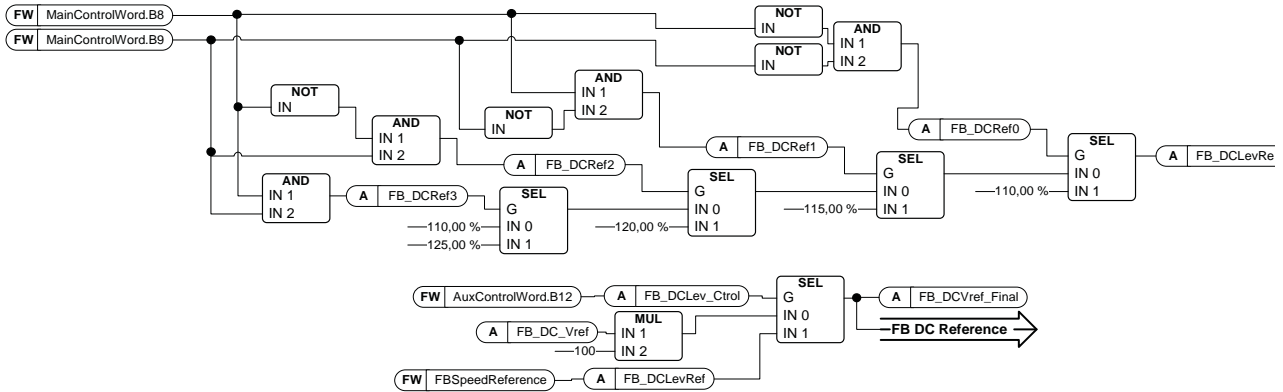

11292 0

Figure 15. FB DC Reference Chain

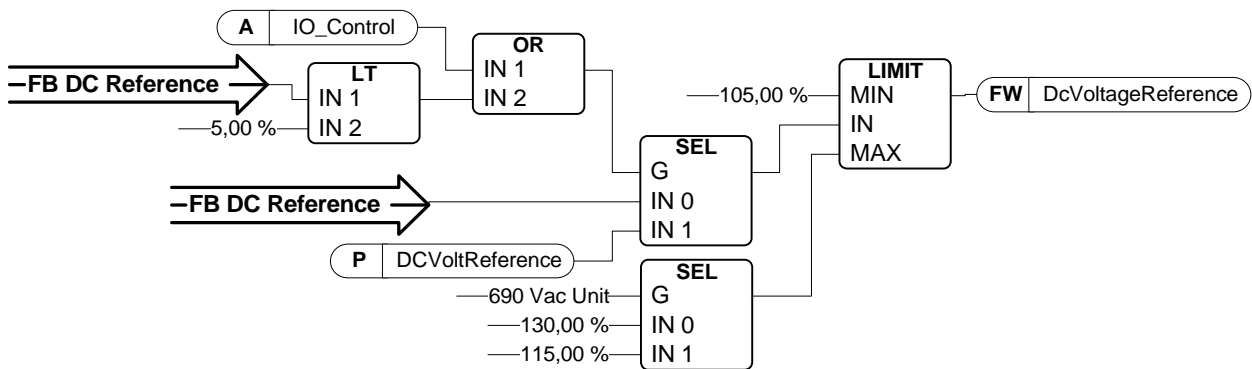

11285_00

Figure 16. DC Voltage Reference Chain

B02: FALSE = No Function, TRUE = DC Ref 1

B03: FALSE = No Function, TRUE = DC Ref 2

Table 52. FB DC Ref Bit control

DC Ref	110.00%	115.00%	120.00%	125.00%
B02	FALSE	TRUE	FALSE	TRUE
B03	FALSE	FALSE	TRUE	TRUE

B04: FALSE = FB WD Pulse Low, TRUE = FB WD Pulse High

Watch dog pulse: This pulse is used to monitor that PLC is alive. If the pulse is missing, the drive will go to fault state. This function is activated by P2.7.6 FB WD Delay. When the value is zero, the pulse is not monitored.

B12: FALSE = DC Ref FB Speed Ref, TRUE = DC Ref controlled by Bits

DC Ref FB Speed Ref: Fieldbus reference is given by FBSpeedReference process data. Reference scaling 110 = 110.00% DC Reference.

DC Ref Controlled By Bits: DC Reference is controlled by main control word bits B08 and B09.

B13: FALSE = DO Control Low, TRUE = DO Control High

DO Control Low: DO is controlled Low.

DO Control High: DO is controlled High

8.13 AUX STATUS WORD ID 1163

Table 53. Aux Status Word

	FALSE	TRUE
b0		
b1		
b2		
b3		
b4		
b5		
b6		
b7		
b8		
b9		
b10		
b11		
b12		
b13		
b14		
b15		

B00: FALSE = No Function, TRUE = No Function

No Function:

No Function:

8.14 STATUS WORD (APPLICATION) ID 43

Application Status Word combines different drive statuses to one data word.

Table 54. Application Status Word ID43

	FALSE	TRUE
b0		
b1	Not in Ready state	Ready
b2	Not Running	Running
b3	No Fault	Fault
b4		
b5		
b6	Run Disabled	Run Enable
b7	No Warning	Warning
b8		Charging Switch closed (internal)
b9		Main Contactor Control (DO Final)
b10		Main Contactor Feedback
b11		
b12	No Run Request	Run Request
b13		
b14		F1, F31 or F41 active
b15		

B01: FALSE = Not Ready, TRUE = Ready

Not Ready: DC Voltage low, Fault active

Ready: Drive in ready state, start command can be given.

B02: FALSE = Not Running, TRUE = Running

Not Running: Drive is not modulating

Running: Drive is modulating.

B03: FALSE = No Fault, TRUE = Fault Active

No Faults: Drive does not have active faults.

Fault: Drive has active faults.

B06: FALSE = Run Enable Low, TRUE = Run Enable High

Run Enable Low: Run Enable command to motor control is low

Run Enable High: Run Enable command to motor control is high.

B07: FALSE = No Warning, TRUE = Warning Active

No Warning: No warning signals active in the drive

Warning: Drive has an active warning signal. The warning signal does not stop the operation.

B08: FALSE = Charging Switch Open, TRUE = Charging Switch closed

Charging Switch Open: DC voltage level has neither reached closing level nor has dropped below the opening level. This information is from the drive motor control.

Charging switch Closed: DC voltage level is above closing limit and no interlocks are active internally.

B09: FALSE = Main contactor Open command, TRUE = Main contactor closed command

Main Contactor Open Command: Final command to open the main contactor from application logic.

Main Contactor Close Command: Final close command to the main contactor from application logic.

B10: FALSE = Main contactor Open, TRUE = Main contactor closed

Main Contactor Open: Feedback from the main contactor, contactor open.

Main Contactor Closed: Feedback from the main contactor, contactor closed.

B10: FALSE = No Run Request, TRUE = Run Request

No Run Request: Final Run Request command has not been given to the motor control.

Run Request: Final Run Request command has been given to the motor control.

9. FAULT CODES

The fault codes, their causes and correcting actions are presented in the table below.

NOTE: When contacting a distributor or the factory because of a fault condition, always write down all texts and codes on the keypad display. The best way is to send the parameter file and service info to VACON® technical support.

This chapter includes all fault codes that are possible. Some faults are not possible in AFE application. Some fault descriptions may be different when compared to standard AC drive.

Table 55. Fault codes

Fault code	Fault name	Description	Possible cause	Remedy
F1	Over current fault	Drive has detected a high current in the output phase.	Sudden increase in load.	Check the DC-Link load.
		S1 = Hardware trip: Current above 4*Ih	Short circuit in cables. Voltage dip in grid.	Check the cables.
F2	Overvoltage fault	DC-link voltage has exceeded the drive protection limits.	Too short a deceleration time in units connected to DC-Link.	Increase deceleration time. Use brake chopper and brake resistor. Use brake chopper unit.
		S1 = Hardware trip. 500 Vac unit DC voltage above 911 Vdc 690 Vac unit DC voltage above 1200 Vdc S2 = Overvoltage control supervision (only 690 Vac unit). DC voltage has been above 1100 Vdc for too long.	High overvoltage spikes in supply. Too low Generator power limit or current limit.	Check input voltage.
F3	Earth fault	Earth fault protection ensures that the sum of the phase currents is zero. The over current protection is always working and protects the AC drive from earth faults with high currents.	Insulation failure in cables.	
		S1 = Sum of output phase current is not zero		

Table 55. Fault codes

Fault code	Fault name	Description	Possible cause	Remedy
F5	Charge switch	Charge switch status is not correct when the start command is given. S1 = Charge switch was open when START command was given.	Charge switch was open when the START command was given.	Check the connection of the feedback from charging relay Reset the fault and restart. Should the fault re-occur, contact your local distributor.
F7	Saturation fault	S1 = Hardware failure		Cannot be reset from the keypad. Switch off power. DO NOT RE-CONNECT POWER! Contact your local distributor.
F8	System Fault	A system fault indicates several different fault situations in drive operation. S7 = Charge switch S8 = No power to driver card S9 = Power unit communication (TX) S10 = Power unit communication (Trip) S11 = Power unit comm. (Measurement) S30 = Safe disable inputs are in different state (OPT-AF) S31 = Thermistor short circuit detected (OPT-AF) S32 = OPT-AF board has been removed S33 = OPT-AF board EEPROM error	Disturbance. Driver board or IGBT broken. FR9 and the bigger size drives, which do not include star coupler: ASIC board (VB00451) is broken. FR8 and smaller size drives: control board broken. FR8 and smaller size drives: if the boards VB00449 / VB00450 are in use, failure might be in there.	Reset the unit and try again. If there is a star coupler in the unit, check the fibre connections and phase order.
F9	Undervoltage fault	DC-link voltage is below the fault voltage limit of the drive. S1 = DC-link too low during run S2 = No data from power unit S3 = Undervoltage control supervision	Too low a supply voltage. AC drive internal fault. One of the input fuses is broken. External charge switch has not been closed. Voltage dip in a grid.	In case of temporary supply voltage break, reset the fault and restart the AC drive. Check supply voltage. Check function of DC charge. Contact your local distributor.

Table 55. Fault codes

Fault code	Fault name	Description	Possible cause	Remedy
F10	Line Synchronization Fault	S1 = Phase supervision diode supply S2 = Phase supervision active front end	Input line phase is missing. Rated current of supply is too low compared to the AFE unit. Grid frequency is too high or too low. Main Circuit Breaker is open. DC-Link has too high motoring power during AFE start.	Check supply voltage, fuses and cable.
F11	Line phase supervision	Current measurement has detected that there is no current in one phase or one phase current is considerably different from the other phases.		Check the cables.
F13	Drive under temperature fault		Heatsink temperature is under -10 C.	
F14	Drive over temperature fault		Heatsink temperature is over acceptable limits. Overtemperature warning is issued before the actual trip limit is reached.	Check the correct amount and flow of the cooling air. Check the heatsink for dust. Check ambient temperature. Make sure that switching frequency is not too high in relation to the ambient temperature and motor load.
F18	Unbalance (Warning only)		Unbalance between power modules in paralleled units. Subcode in T.14: S1 = Current unbalance S2 = DC-Voltage unbalance	Should the fault re-occur, contact your local distributor.
F22	EEPROM checksum fault		Parameter save fault. Faulty operation. Component failure.	Should the fault re-occur, contact your local distributor.
F24	Counter fault		Values displayed on counters are incorrect.	Have a critical attitude towards values shown on counters.

Table 55. Fault codes

Fault code	Fault name	Description	Possible cause	Remedy
F25	Microprocessor watchdog fault		Start-up of the drive has been prevented. Run request is ON when a new application is loaded to the drive.	Reset the fault and restart. Should the fault re-occur, contact your local distributor.
F26	Start-Up prevention		Start-up of the drive has been prevented.	Cancel the prevention of the start-up if this can be done safely.
			Run request is ON when a new application is loaded to the drive.	Remove Run Request.
F29	Thermistor fault	The thermistor input of the option board has detected too high motor temperature.	Motor is overheated.	Check the motor cooling and load.
			Thermistor cable is broken.	Check the thermistor connection (If thermistor input of the option board is not in use it has to be short circuited).
F31	IGBT temperature	IGBT Inverter Bridge over temperature protection has detected too high short term overload current.	Too high load.	Check load.
			Identification run has not been made which causes the motor to start under magnetized.	Check motor size.
				Make identification Run.
F32	Fan cooling		Cooling fan of the AFE or LCL filter (with integrated power supply) does not start or is not running when ON command is given.	Contact your local distributor.
F37	Device change	Option board or power unit changed.	New device of same type and rating.	Reset. Device is ready for use.
F38	Device added	Option board added.		Reset. Device is ready for use. Old board settings will be used.
F39	Device removed	Option board removed.		Reset. Device no longer available.
F40	Device unknown	Unknown option board or drive. S1 = Unknown device S2 = Power1 not same type as Power2		Contact the distributor near to you.

Table 55. Fault codes

Fault code	Fault name	Description	Possible cause	Remedy
F41	IGBT temperature	IGBT inverter bridge over-temperature protection has detected too high short term overload current.		Check load.
F44	Device changed (Default param.)		Option board or power unit changed. New device of different type or different rating from the previous one.	Reset. Set the option board parameters again if the option board was changed. Set the AC drive parameters again if the power unit was changed.
F45	Device added (default param.)		Option board of different type added.	Reset Set the option board parameters again.
F51	External fault		Digital input fault.	Remove fault situation from the external device.
F52	Keypad communication		The connection between the control keypad or NCDrive and the AC drive is broken.	Check the keypad connection and possible keypad cable.
F53	Fieldbus communication		The data connection between the fieldbus Master and the fieldbus board is broken.	Check installation. If installation is correct contact the nearest distributor.
F54	Slot fault		Defective option board or slot.	Check board and slot. Contact the nearest distributor.
F56	PT100 temperature fault	PT100 protection function is used to measure the temperature and give a warning and/or fault when the set limits are exceeded.	Temperature limit values set for the PT100 board parameters have been exceeded.	Find the cause of temperature rise.
F60	Cooling	Protection for the liquid-cooled units. An external sensor is connected to the drive (DI: Cooling Monitor) to indicate if cooling liquid is circulating. If the drive is in Stop state, only a warning is issued. In Run state a fault is issued and the drive makes a coast stop.	The cooling circulation of the liquid cooled drive has failed.	Check the reason for the cooling failure from the external system.

Table 55. Fault codes

Fault code	Fault name	Description	Possible cause	Remedy
F64	MCC State Fault	A1 = Code given by V139 and older versions. A2 = MCB open while controlled close. A3 = MCB closed while controlled open. A4 = MCB opened externally while AFE unit was in run state.	Main contactor has opened while the drive controls it to close. Main contactor is closed while the drive controls it to open.	Check the main contactor functionality.
F70	LCL Fan Fault		LCL Fan feedback signal to digital input indicates that LCL fan is not running.	Check the connections. Check if the LCL filter (with external DC-power supply) fan is running or not. Check the external power supply if the fan is not running. Contact the nearest distributor.
F71	LCL Temperature	LCL Temperature has reached a warning limit.		
F80	Charging Fault	Drive has not reached the needed voltage at set time	Too high load in DC bus. Charging current too low.	Check the charging current.

VACON[®]

www.danfoss.com

Vacon Ltd
Member of the Danfoss Group
Runsorintie 7
65380 Vaasa
Finland

Document ID:



DPD00905B

Rev. B

Sales code: DOC-APPLAFE+DLUK