

Ground Bar Kit for FK11/FB11 and FK12/FB12 iC7 Series Frequency Converters

1 Overview

1.1 Description

The ground bar kit fits iC7 Series Frequency Converters in the following frames:

- FB11 (IP54/UL Type 12)
- FK11 (IP21/UL Type 1)
- FB12 (IP54/UL Type 12)
- FK12 (IP21/UL Type 1)

The frame and protection rating are listed on the frequency converter product label.

1.2 Kit Numbers

Use these instructions with the following kit.

Table 1: Number for Ground Bar Kits

Number	Kit description
176F4188	Ground bar kit for FK11/FB11, FK12/FB12

1.3 Items Supplied

The following parts are contained in the kit.

Table 2: Items Supplied in Ground Bar Kit

Item	Quantity
Ground bar	2
Angle bracket	2
M5x18 mm screw	4
M6 hex nut	4

2 Installation

2.1 Safety Information

NOTICE

QUALIFIED PERSONNEL

Only qualified, Danfoss authorized personnel are allowed to install the parts described in these installation instructions.

- Disassembly and reassembly of the frequency converter must be done in accordance with the service guide.
- Use the standard fastener torque values from the service guide, unless the torque value is specified in these instructions.

⚠ WARNING ⚠

DISCHARGE TIME (40 MINUTES)

The frequency converter contains DC-link capacitors, which can remain charged even when the frequency converter is not powered. High voltage can be present even when the warning LED indicator lights are off. Failure to wait 40 minutes after power has been removed before performing service or repair work can result in death or serious injury.

- Stop the motor.
- Disconnect AC mains and remote DC-link power supplies, including battery back-ups, UPS, and DC-link connections to other frequency converters.
- Disconnect or lock the motor.
- Disconnect any brake option.
- Disconnect any DC connector option.
- Wait 40 minutes for the DC-link capacitors to discharge fully.
- Before performing any service or repair work, measure the voltage level to verify that the capacitors are fully discharged.

⚠ WARNING ⚠

ELECTRICAL SHOCK HAZARD

The frequency converter contains dangerous voltages when connected to mains voltage. Improper installation, and installing or servicing with power connected, can cause death, serious injury, or equipment failure.

- Only use qualified electricians for the installation.
- Disconnect the frequency converter from all power sources before installation or service.
- Treat the frequency converter as live whenever the mains voltage is connected.
- Follow the guidelines in these instructions and local electrical safety codes.

NOTICE

ELECTROSTATIC DISCHARGE

Electrostatic discharge can damage components.

- Ensure electrostatic discharge before touching internal frequency converter components, for example by touching a grounded, conductive surface or by wearing a grounded armband.

2.2 Assembling the Ground Bars

The ground bar kit includes 2 ground bars, 1 for the mains input side and 1 for the motor side of the frequency converter. Use the following steps to assemble the ground bars before installation.

1. Place the 1st ground bar over the 2 threaded posts on 1 of the angle brackets.
2. Fasten 2 M6 hex nuts (T30) to the bracket posts, 1 on each post.

Torque to 3.9 Nm (35 in-lb).

3. Repeat for remaining ground bar and angle bracket.

Position the 2nd ground bar with the long end oriented in the opposite direction on the bracket. When correctly assembled, the 2 ground bars mirror each other.

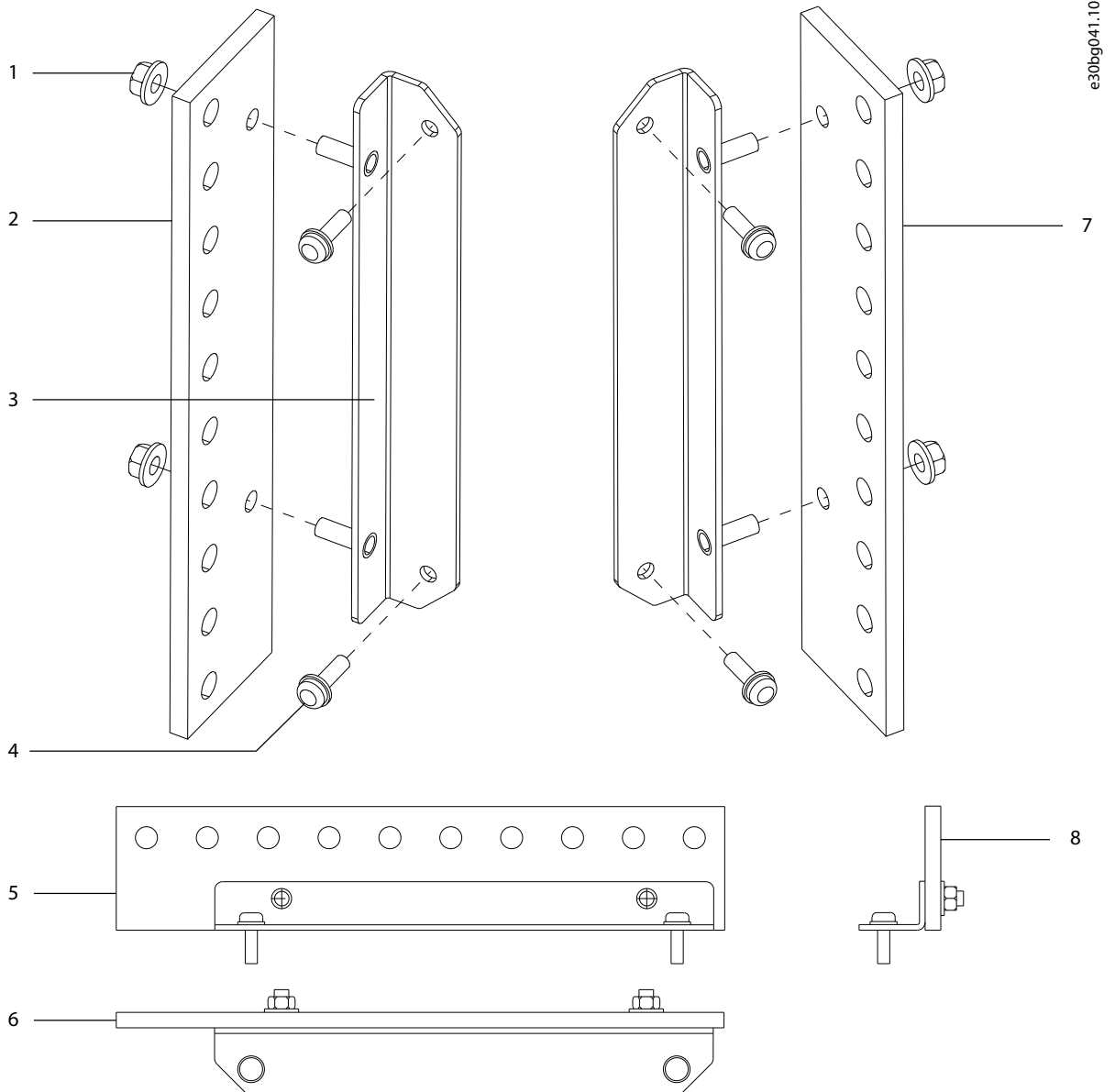

Illustration 1: Assembly of Ground Bars and Angle Brackets

1	M6 hex nut	5	Side view of assembled ground bar and bracket
2	Ground bar assembly for mains side	6	Front view of assembled ground bar and bracket
3	Angle bracket	7	Ground bar assembly for motor side
4	M5x18 mm screw	8	End view of assembled ground bar and bracket

2.3 Installing the Ground Bars

After assembling the ground bars, use the following steps to install them in the frequency converter.

1. Remove 4 screws from the mounting holes in the midplate, 2 from each side of the frequency converter.

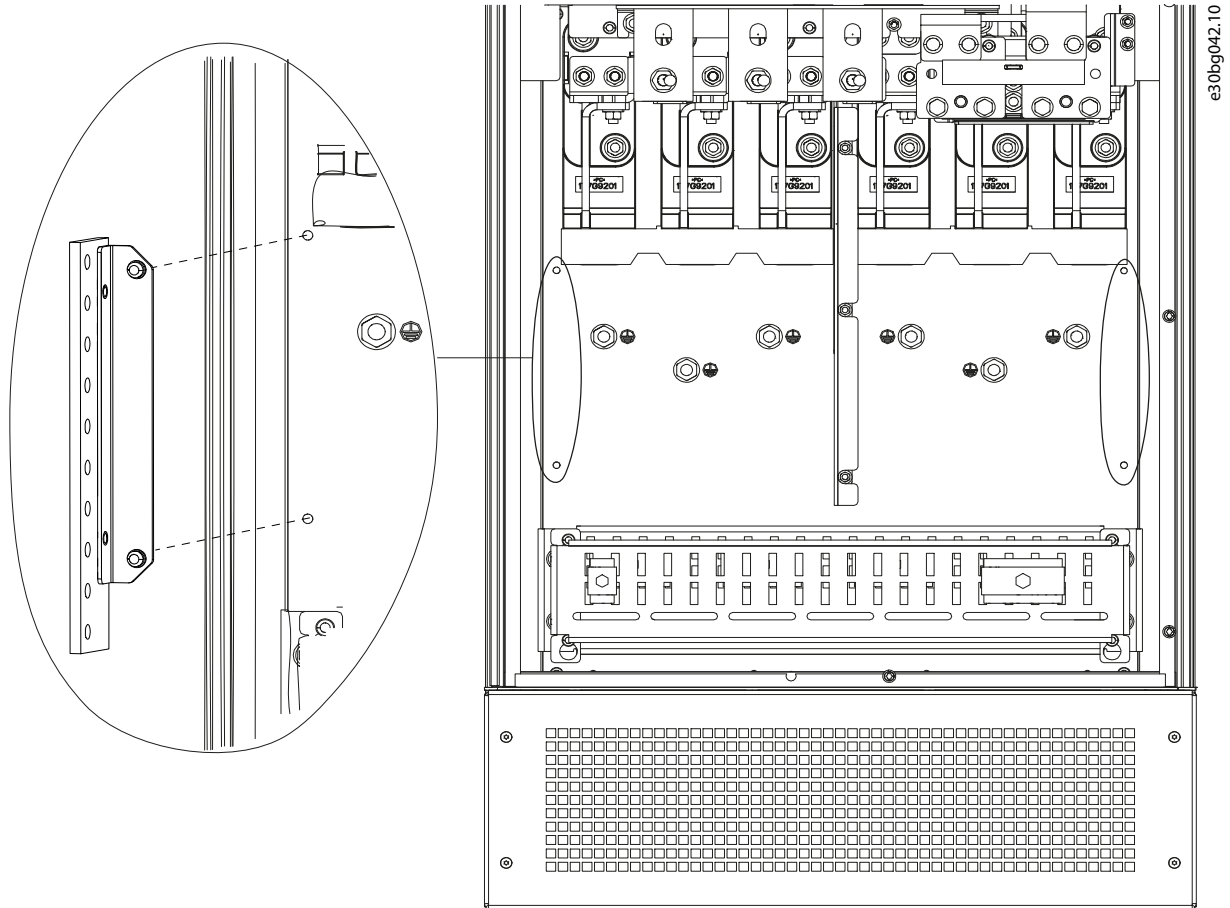

Illustration 2: Location of Ground Bar Mounting Holes in Midplate

2. Position the 2 angle brackets with attached ground bars over the mounting holes in the midplate.
3. Fasten angle brackets to the midplate with 4 M5x18 mm screws (T25), 2 in each angle bracket.

Tighten to 2.3 Nm (20 in-lb).

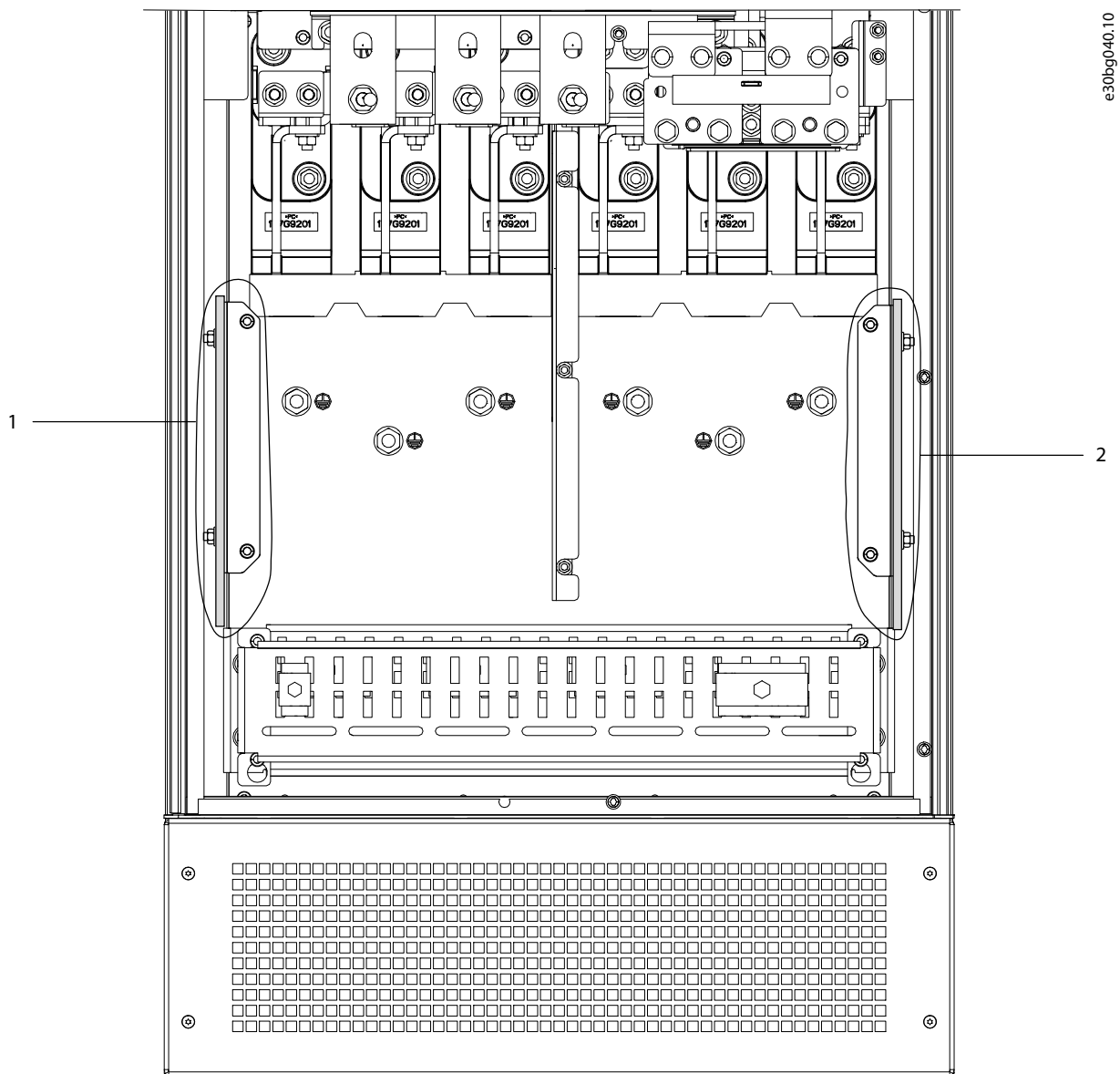

Illustration 3: Installation of Ground Bars and Angle Brackets

- | | |
|---|-----------------------|
| 1 | Mains side ground bar |
| 2 | Motor side ground bar |

Danfoss A/S
Ulsnaes 1
DK-6300 Graasten
drives.danfoss.com

Any information, including, but not limited to information on selection of product, its application or use, product design, weight, dimensions, capacity or any other technical data in product manuals, catalogues descriptions, advertisements, etc. and whether made available in writing, orally, electronically, online or via download, shall be considered informative, and is only binding if and to the extent, explicit reference is made in a quotation or order confirmation. Danfoss cannot accept any responsibility for possible errors in catalogues, brochures, videos and other material. Danfoss reserves the right to alter its products without notice. This also applies to products ordered but not delivered provided that such alterations can be made without changes to form, fit or function of the product. All trademarks in this material are property of Danfoss A/S or Danfoss group companies. Danfoss and the Danfoss logo are trademarks of Danfoss A/S. All rights reserved.

