

In-back/Out-back Cooling Kit for FA09-FA10 iC7 Series Frequency Converters

1 Overview

1.1 Description

The in-back/out-back cooling kit fits FA09 and FA10 frequency converters mounted in Rittal TS8 cabinets. When the kit is installed, air flows into the lower back duct and out through the upper back duct of the frequency converter. See [Illustration 1](#).

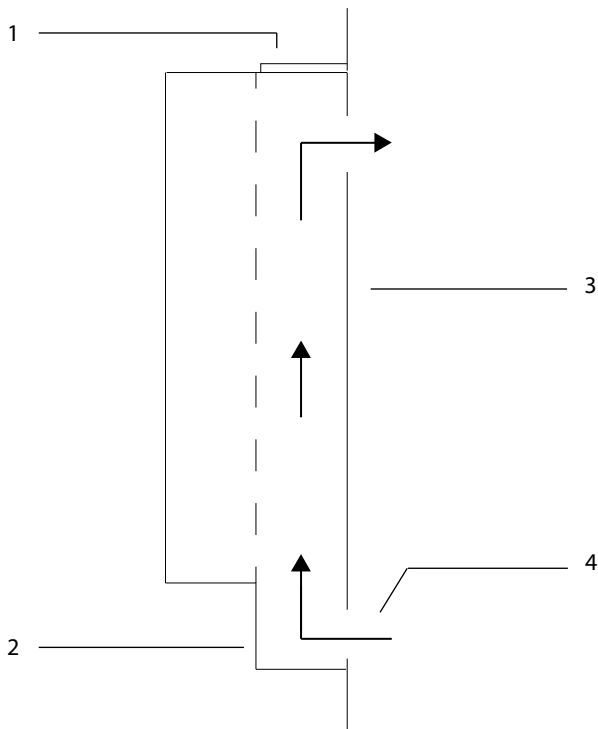

e30bx518.10

Illustration 1: Direction of Airflow with the Kit Installed

1	Top cover	3	Airflow direction
2	Cooling back channel	4	Lower duct (intake)

1.2 Kit Numbers

Use these instructions with the following kits.

Table 1: In-back/Out-back Cooling Kits

Number	Kit description
176F4045	In-back/out-back cooling kit for FA09 frequency converter
176F4046	In-back/out-back cooling kit for FA10 frequency converter

1.3 Items Supplied

The kit contains the following parts:

Table 2: Contents of In-back/Out-back Cooling Kit

Item	Quantity
Top cover	1
Top cover gasket	1
Strip gasket	1
Upper back vent	1
Upper vent gasket	2
Lower back vent	1
Lower vent gasket	2
Clip-on nut	12
M5x18 screw	12–16
M6x12 screw	10–12
Mounting plate gasket (upper)	2
Mounting plate gasket (lower)	2
Seal plate gasket	2
Seal plate	2
Lower duct frame	1
Front cover, lower duct	1
Front gasket, lower duct	1
Top gasket, lower duct	1
Grill gasket, lower duct	1
Back grill, lower duct	1
Side gasket, lower duct	2
Base cover, lower duct	1
Base gasket, lower duct	1
Drainage tube	1
M5x10 taptite screw	12–14
M5x12 screw	33–35
M10 hex nut	4
M5 hex nut	21–24

2 Installation

2.1 Safety Information

NOTICE

QUALIFIED PERSONNEL

Only qualified personnel are allowed to install the parts described in these installation instructions.

- Disassembly and reassembly of the frequency converter must be done in accordance with the corresponding service guide.
- Use the standard fastener torque values from the service guide, unless the torque value is specified in these instructions.

⚠ WARNING ⚠

ELECTRICAL SHOCK HAZARD

The frequency converter contains dangerous voltages when connected to mains voltage. Improper installation, and installing or servicing with power connected, can cause death, serious injury, or equipment failure.

- Only use qualified electricians for the installation.
- Disconnect the frequency converter from all power sources before installation or service.
- Treat the frequency converter as live whenever the mains voltage is connected.
- Follow the guidelines in these instructions and local electrical safety codes.

⚠ WARNING ⚠

DISCHARGE TIME (20 MINUTES)

The frequency converter contains DC-link capacitors, which can remain charged even when the frequency converter is not powered. High voltage can be present even when the warning indicator lights are off.

Failure to wait 20 minutes after power has been removed before performing service or repair work can result in death or serious injury.

- Stop the motor.
- Disconnect AC mains, permanent magnet type motors, and remote DC-link supplies, including battery back-ups, UPS, and DC-link connections to other frequency converters.
- Wait 20 minutes for the capacitors to discharge fully before performing any service or repair work.
- Measure the voltage level to verify full discharge.

NOTICE

ELECTROSTATIC DISCHARGE

Electrostatic discharge can damage components.

- Ensure discharge before touching internal frequency converter components, for example by touching a grounded, conductive surface or by wearing a grounded armband.

2.2 Installation Overview

NOTICE

APPLYING GASKETS

This kit contains self-adhesive gaskets to ensure a proper seal between metal parts.

- Before affixing a gasket, check that the part matches the gasket and that no holes are covered.

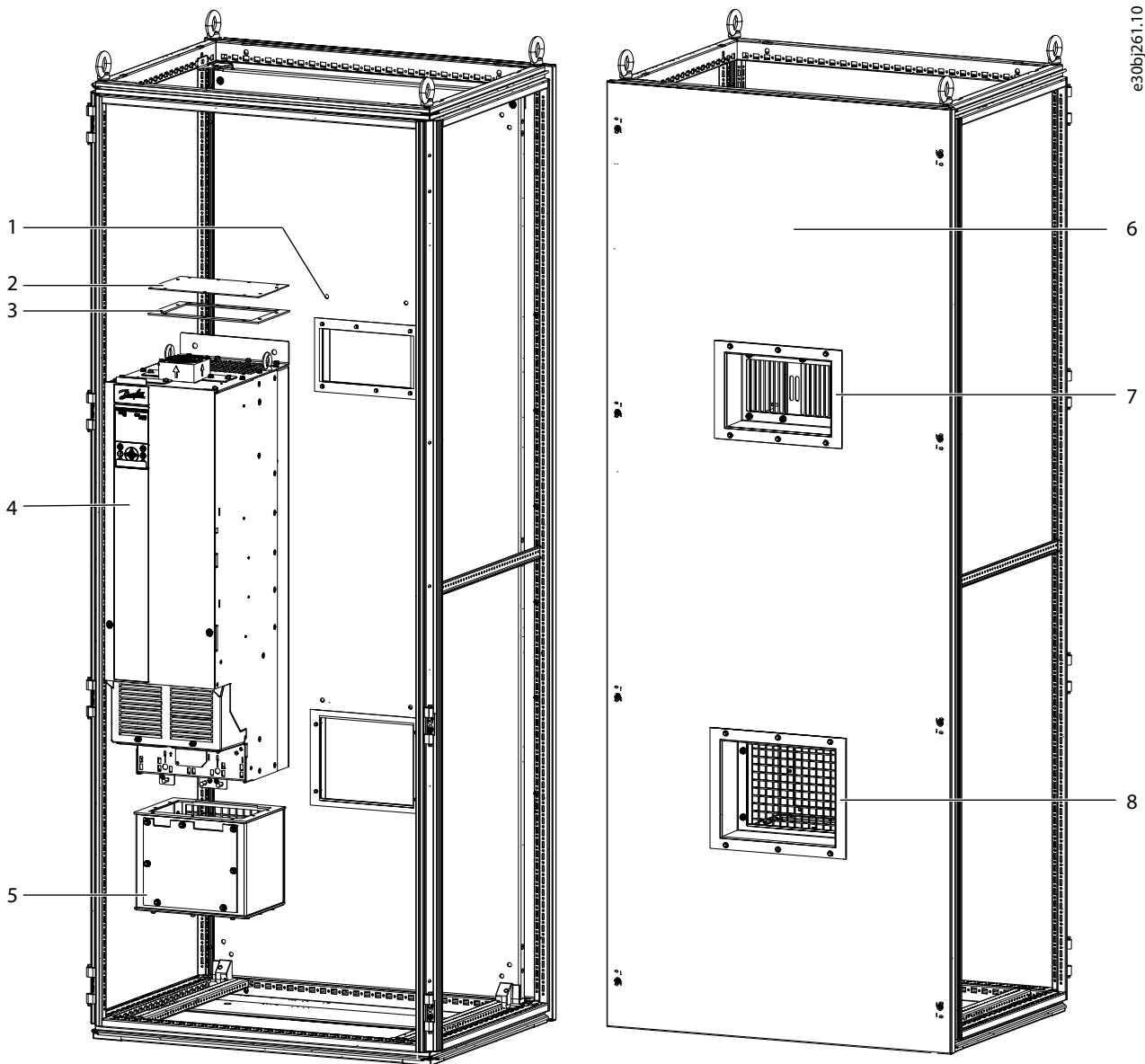

Illustration 2: Overview of In-bottom/Out-top Cooling Kit

1	Mounting holes	5	Lower duct
2	Top cover	6	Cabinet backplate
3	Top cover gasket	7	Upper back vent
4	Frequency converter	8	Lower back vent

2.3 Preparing the Mounting Plate

To create mounting holes and vent holes in the mounting plate, use the following steps. Refer to [Illustration 3](#) for FA09 frequency converters, and [Illustration 4](#) for FA10 frequency converters.

Procedure

1. Drill 4 mounting holes in the mounting plate using the dimensions in the FA09 or FA10 template.

The holes must match the holes in the frequency converter.

2. Insert 4 M10 pem studs (not supplied) in the mounting holes.
3. Cut out the 2 vent openings in the mounting plate using the dimensions in the FA09 or FA10 template.

The openings must match the upper and lower duct openings.

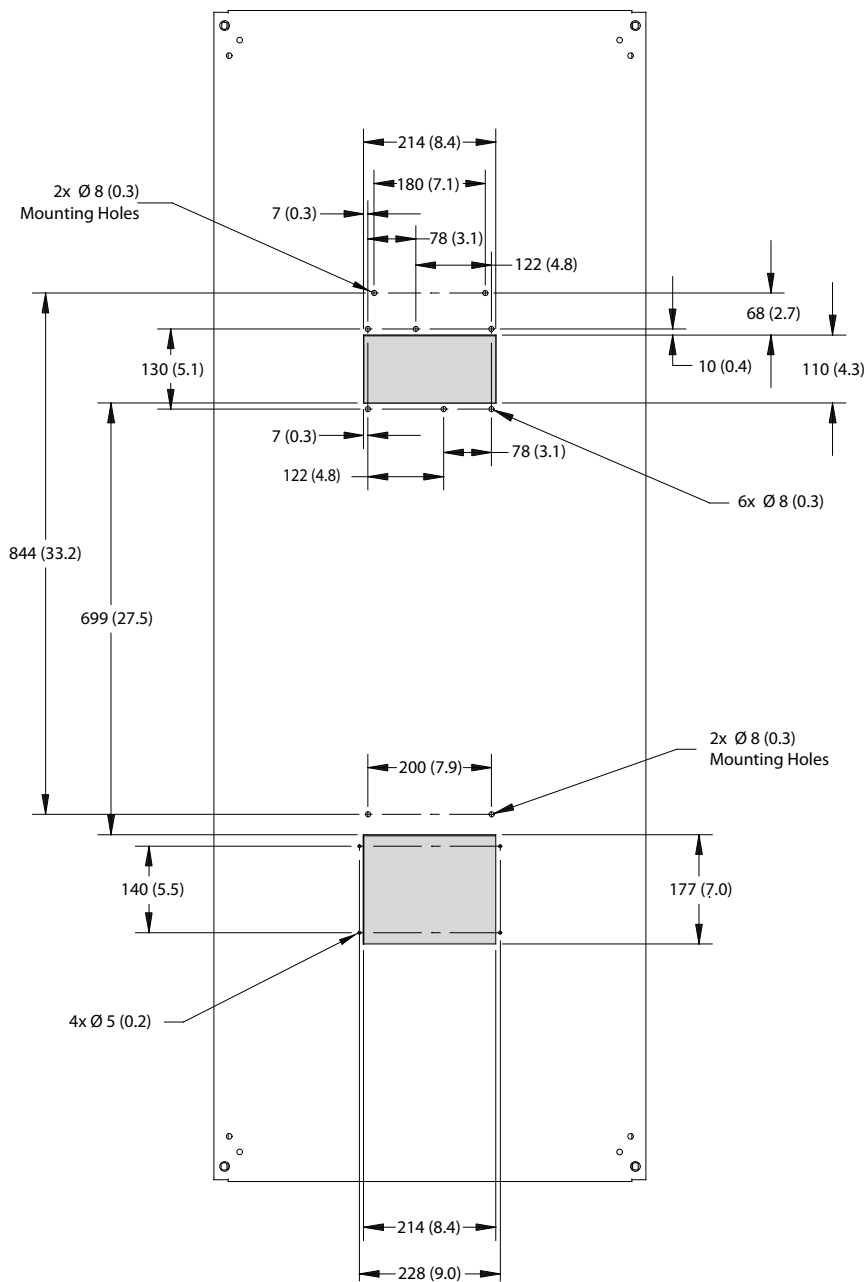

e30bj160.10

Illustration 3: FA09 Mounting Plate Template for In-back/Out-back Cooling

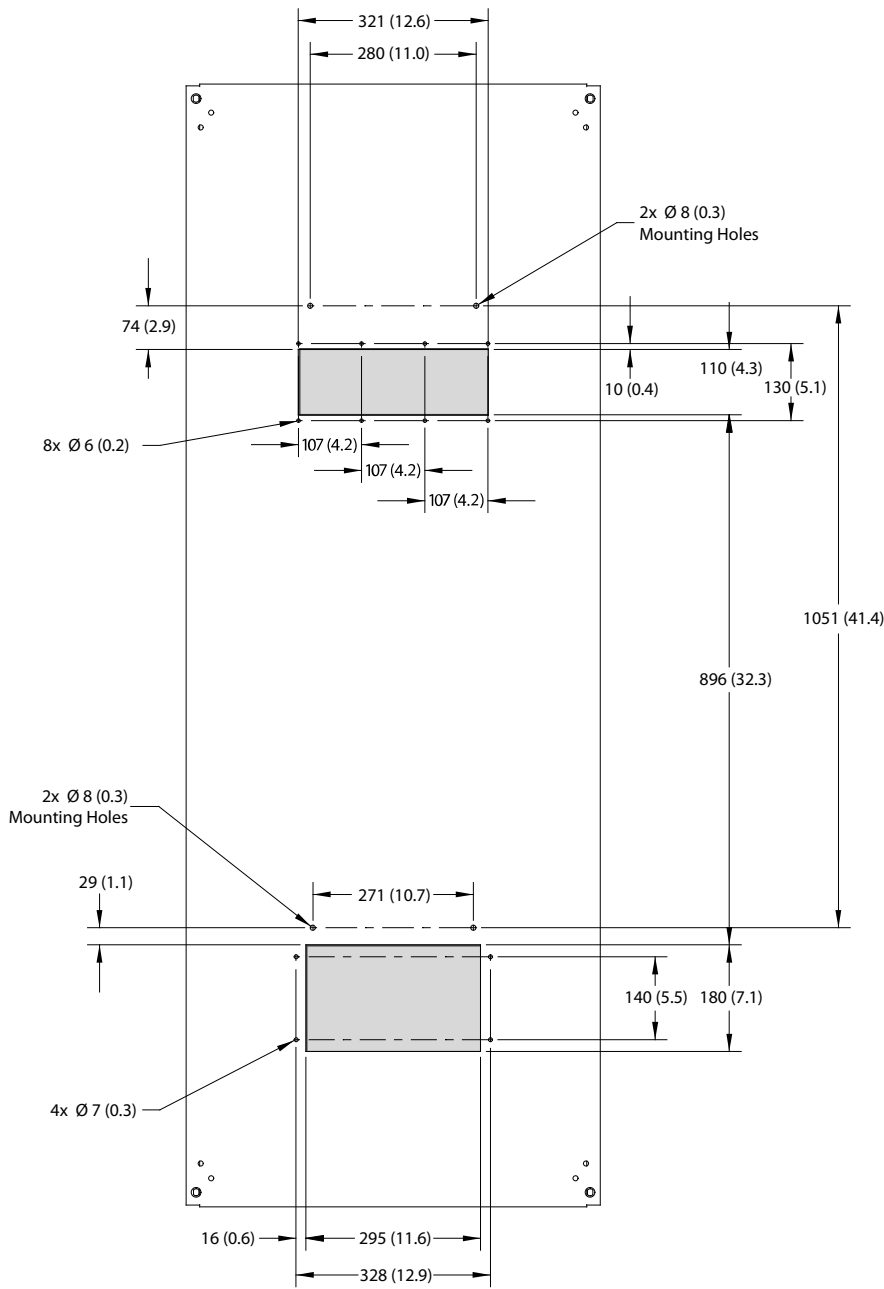

Illustration 4: FA10 Mounting Plate Template for In-back/Out-back Cooling

2.4 Preparing the Backplate

To create vent openings in the cabinet backplate to match the openings in the mounting plate, use the following steps. Refer to [Illustration 5](#) for FA09 frequency converters and [Illustration 6](#) for FA10 frequency converters.

Procedure

1. Cut out the vent openings in the cabinet backplate using the dimensions in the FA09 or FA10 template.

The openings must match the mounting plate openings.

2. Drill screw holes (6 mm) around the vent openings.

The FA09 requires 6 holes around each vent opening, and the FA10 requires 8 holes around each. The holes must align with the holes in the outer flanges of the ducts.

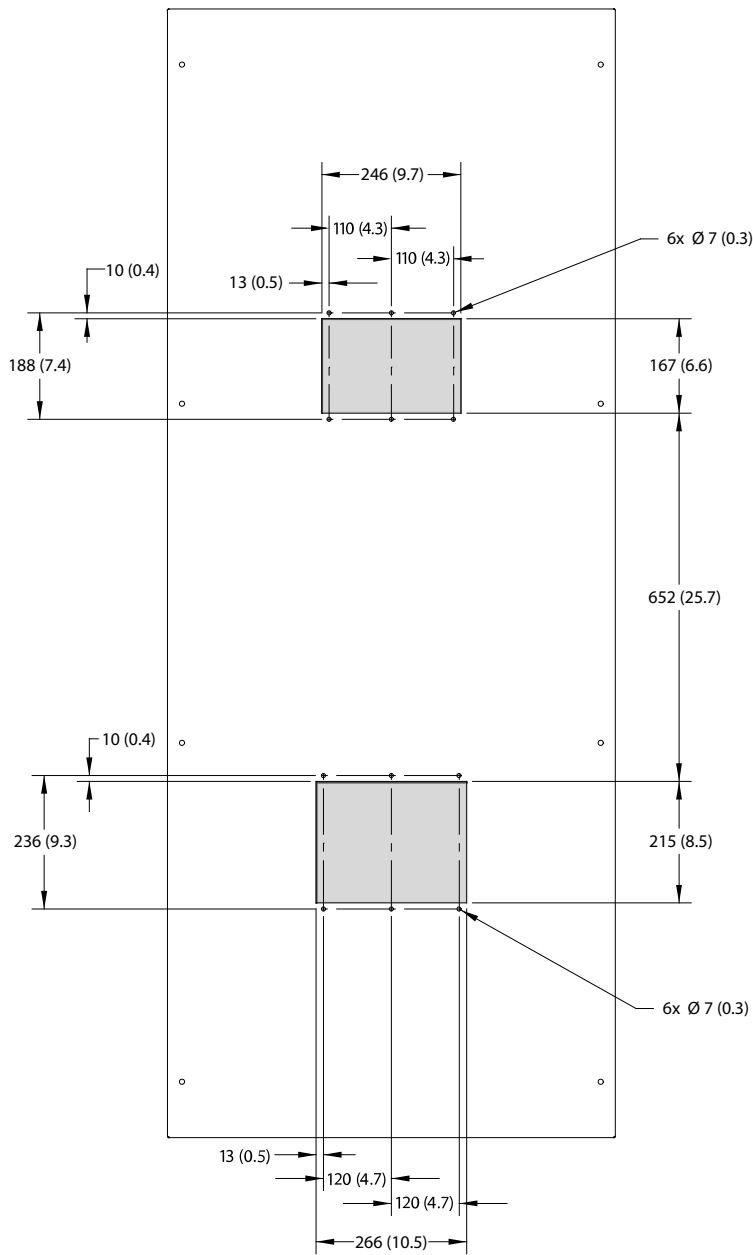

Illustration 5: FA09 Cabinet Backplate Template for In-back/Out-back Cooling

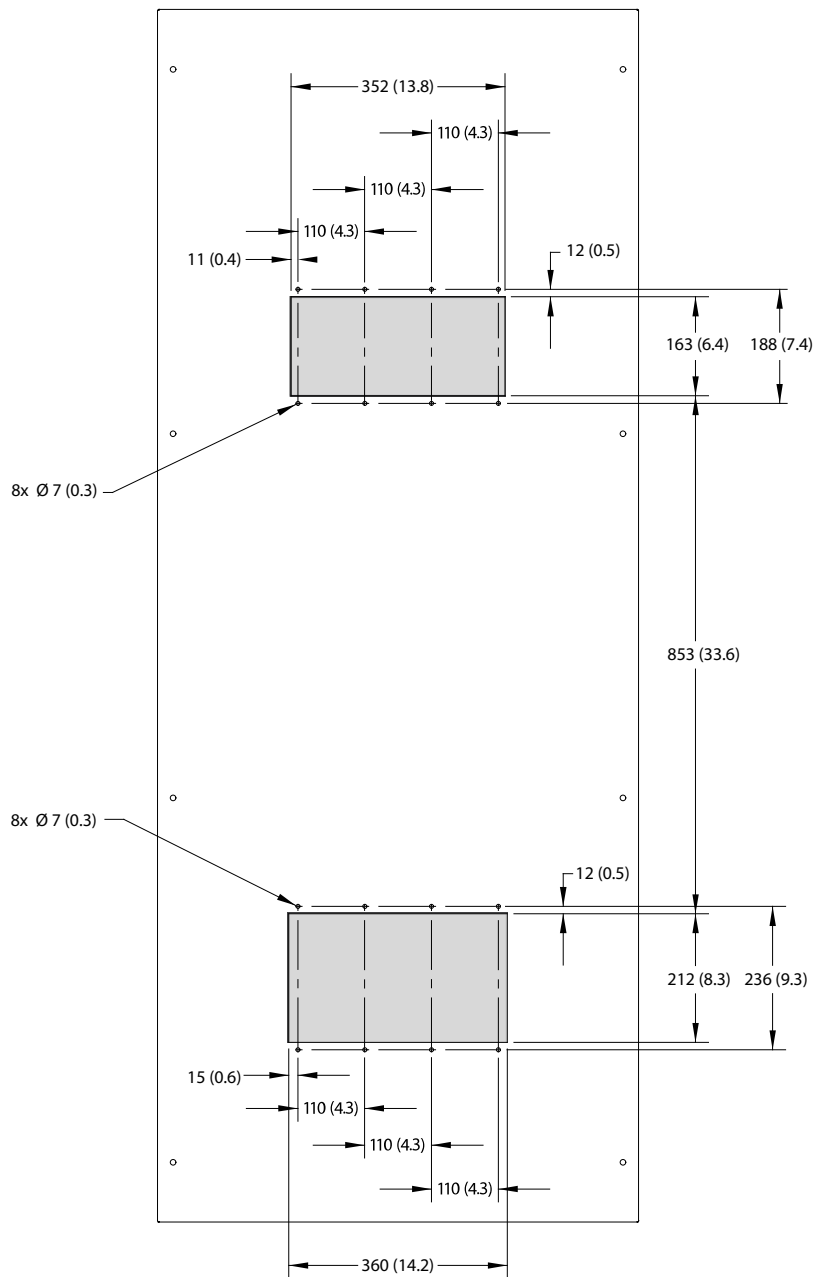

Illustration 6: FA10 Cabinet Backplate Template for In-back/Out-back Cooling

2.5 Installing the Top Cover

To install the top cover of the cooling kit, use the following steps. See [Illustration 7](#).

Procedure

1. Remove the paper backing from the top cover gasket to expose the adhesive.
2. Adhere the top cover gasket to the underside of the top cover.
3. Remove 8 M5x14 screws (T25) surrounding the sides and back of the vent in the top of the frequency converter. Retain the screws.
4. Remove 3 M5x12 screws (T25) at the front of the vent in the top surface of the frequency converter.
5. Slide the edge of the top cover under the 3 loosened screws, positioning the cover over the vent in the top of the frequency converter.
6. Secure the top cover to the frequency converter with the M5x14 screws (T25) removed previously in step 3.

Torque all screws to 2.3 Nm (20 in-lb).

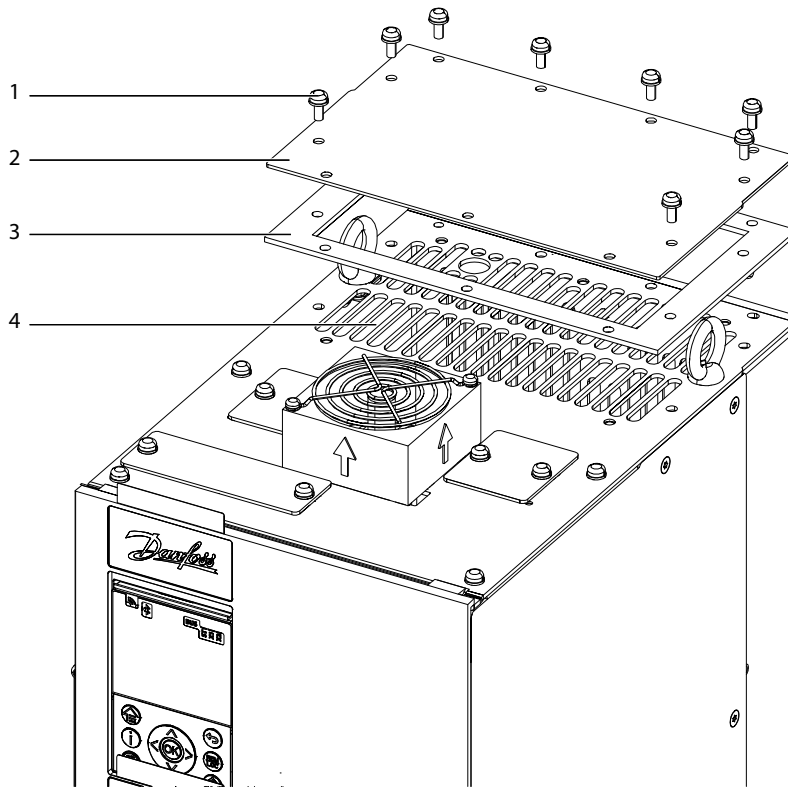

Illustration 7: Installation of the Top Cover

1	M5x14 screws	3	Top cover gasket
2	Top cover	4	Top vent

2.6 Mounting the Frequency Converter

To install the mounting plate and frequency converter in the Rittal cabinet, use the following steps. Refer to [Illustration 8](#).

Procedure

1. Remove the backing paper from the 2 self adhesive upper mounting plate gaskets.
2. Affix the gaskets around the upper opening, 1 on each side of the mounting plate.
3. Remove the backing paper from the 2 self adhesive lower mounting plate gaskets.
4. Affix the gaskets around the lower opening, 1 on each side of the mounting plate.
5. Attach the mounting plate to the cabinet rails, making sure that the pem studs face the front of the cabinet.
6. Remove the backing paper from the 2 seal plate gaskets.
7. Affix the gaskets to the seal plates, 1 per plate.
8. Fasten 2 M10x30 screws through the seal plates, 1 per plate, and into the M10 nuts at the lower end of the mounting plate.

Check that the screws are secure. The base of the frequency converter rests on the screws.

9. Slightly lean the top of the frequency converter forward and set the notches in the base onto the 2 screws.
10. Slowly push the top of the frequency converter back against the mounting plate until the top 2 pem studs line up with the holes in the frequency converter.
11. Secure the top of the frequency converter using 2 M10 nuts.

Torque all fasteners to 19 Nm (170 in-lb).

e30bj184.10

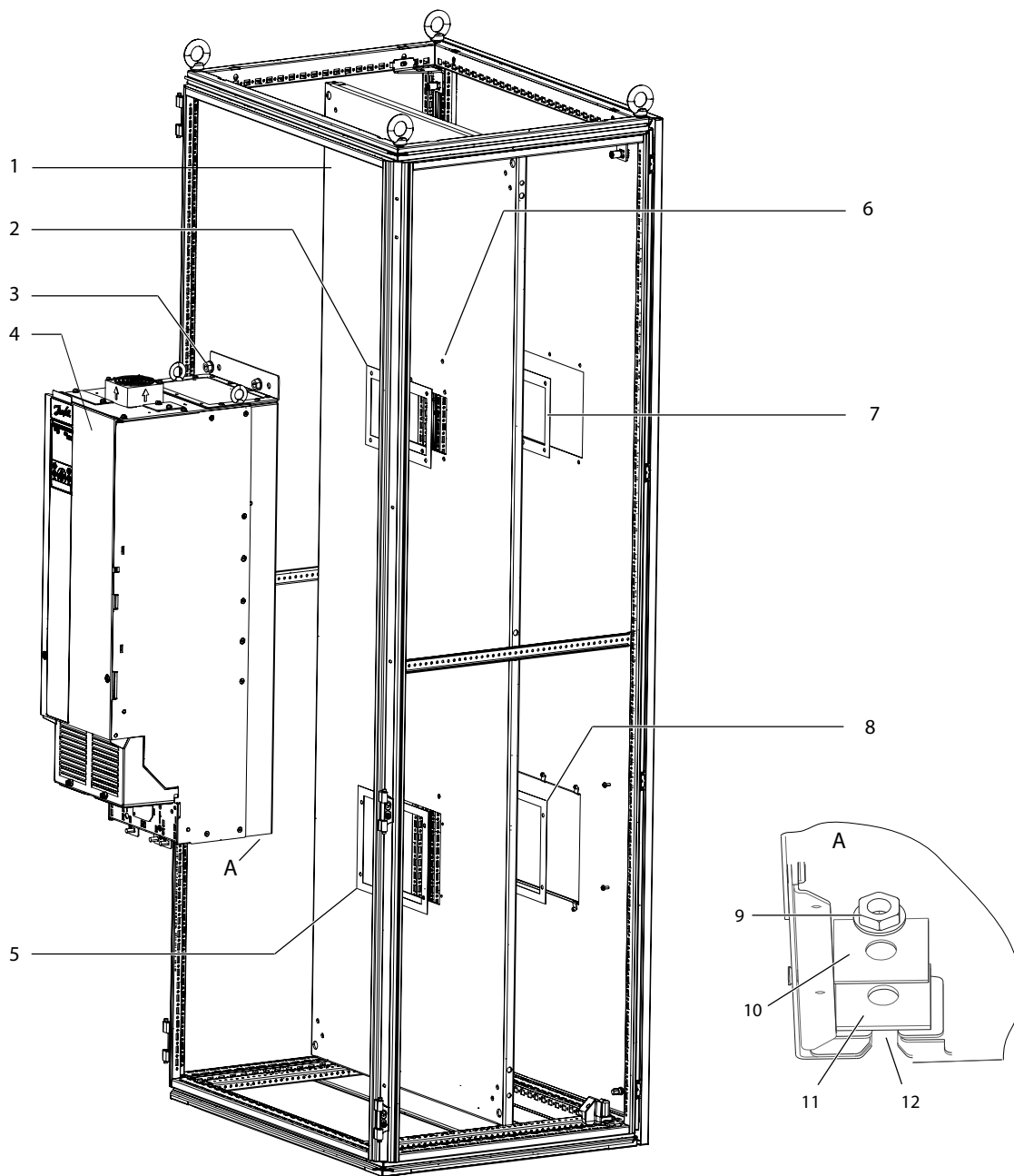

Illustration 8: Installation of the Frequency Converter in the Cabinet

1	Mounting plate	7	Mounting plate gasket (upper)
2	Mounting plate gasket (upper)	8	Mounting plate gasket (lower)
3	M10 nut	9	M10 nut
4	Frequency converter	10	Seal plate gasket
5	Mounting plate gasket (lower)	11	Seal plate
6	Mounting holes	12	Notch in lower edge of frequency converter

2.7 Assembling the Lower Duct

To assemble the lower duct, use the following steps. Refer to [Illustration 9](#).

Procedure

1. Peel the paper from the side gaskets, and press to attach the gaskets to the duct frame.

Align the holes in the side gaskets with the holes in the left and right sides of the back opening of the duct frame.

2. Place the grill over the left and right gaskets, with the threaded studs in the grill going through the middle holes in the gasket and into the duct frame.
3. Secure the grill to the duct frame using 1 M5 nut on each stud.

Torque to 2.3 Nm (20 in-lb).

4. Affix the grill gasket to the outer side of the back grill.
5. Affix the duct base gasket to the duct base cover.
6. Secure the base cover to the underside of the duct frame with 12 M5 nuts (for FA09) or 14 M5 nuts (for FA10).

Torque to 2.3 Nm (20 in-lb).

7. Place the front gasket on the front side of the duct frame, making sure the holes in the frame and gasket align.
8. Affix the top gasket to the top of the duct frame.

Wait to attach the front duct cover until the lower duct assembly is installed in the cabinet.

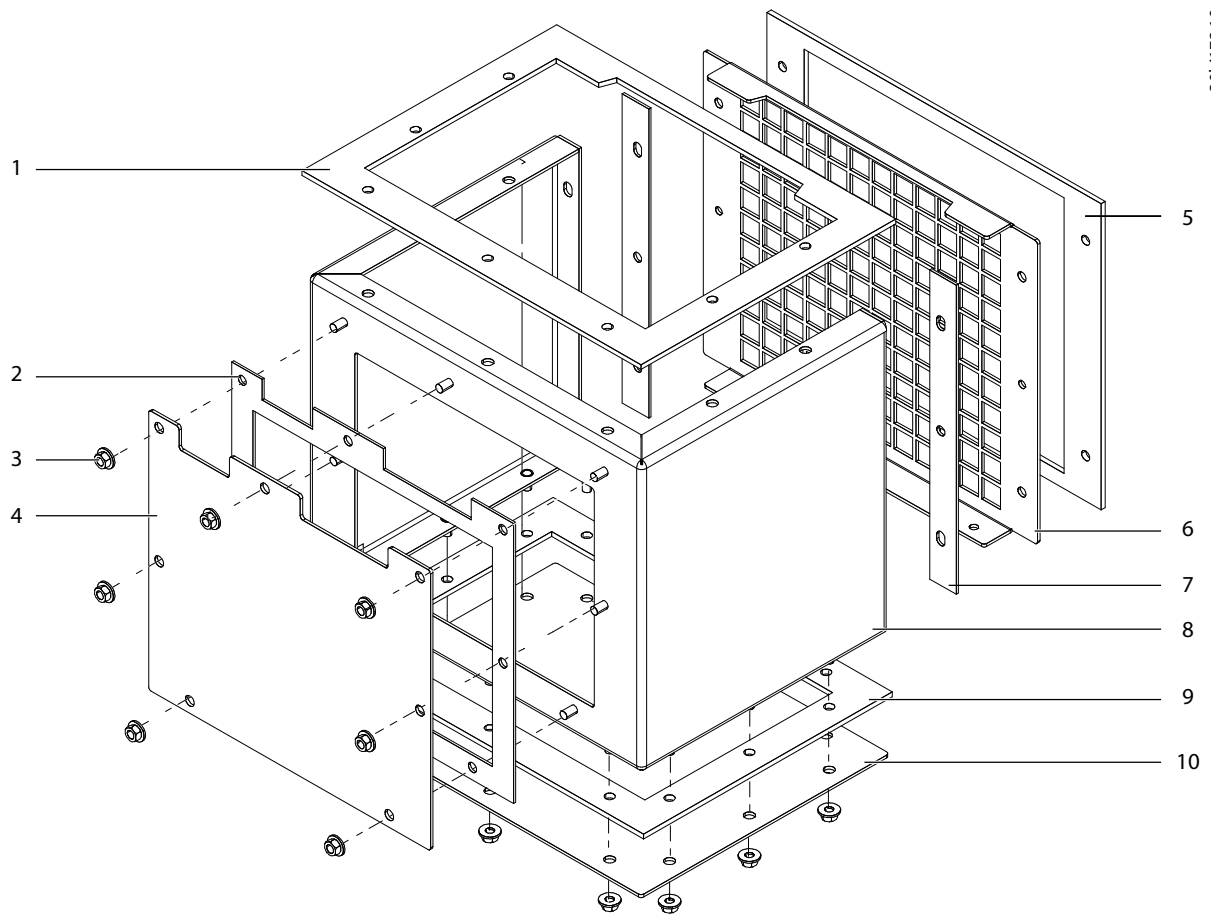

Illustration 9: Assembly of Lower Duct

1	Top gasket	6	Back grill
2	Front gasket	7	Side gaskets, left and right
3	M5 nut	8	Duct frame
4	Front cover	9	Base gasket
5	Grill gasket	10	Duct base cover

2.8 Installing the Lower Duct

To attach the lower duct to the frequency converter, use the following steps.

Procedure

1. Place the strip gasket over the 2 slots at the bottom back of the frequency converter.
2. Remove the cover and gasket from the bottom of the frequency converter by removing 7 screws.

Retain the screws, but discard the cover and gasket.

3. Secure the top flange of the duct to the bottom of the frequency converter using the screws removed in step 2.

Refer to [Illustration 10](#). Torque screws to 2.3 Nm (20 in-lb).

4. Attach the front duct cover.

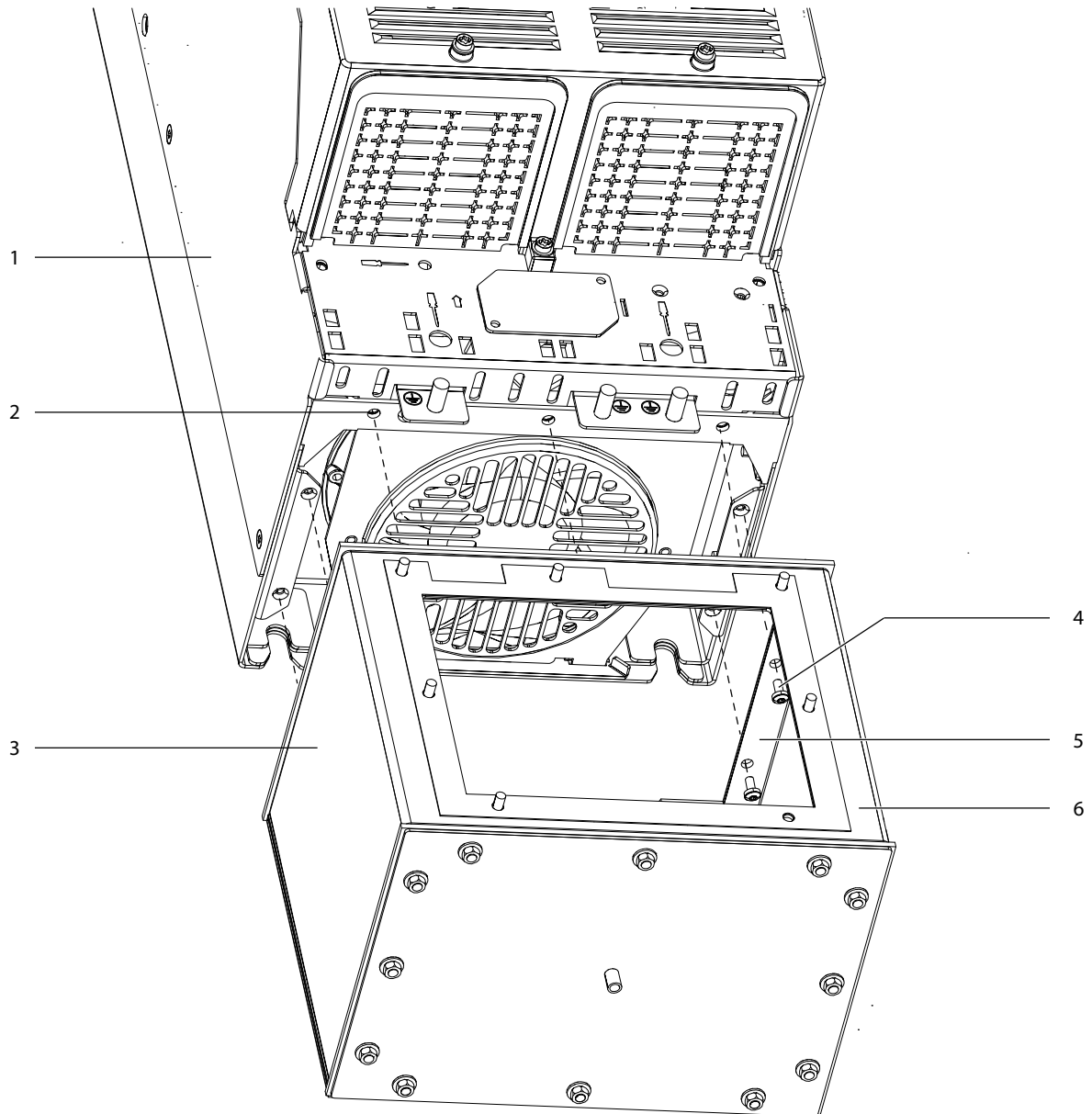

Illustration 10: Installation of Lower Duct

1	Frequency converter	4	Screw
2	Holes for attaching duct	5	Top flange of duct
3	Lower duct	6	Front of duct

2.9 Installing the Back Vents

To install the upper and lower back vents, use the following steps. Refer to [Illustration 11](#).

Procedure

1. To install the upper back vent, use the following steps:
 - a. Slide 6 clip-on nuts over the edge of the upper vent opening in the back plate of the cabinet.
 - b. Seat the clip-on nuts into the 6 holes around the opening.
 - c. Affix 2 upper vent gaskets to the flange of the upper back vent, placing 1 gasket on the inner side and 1 gasket on the outer side of the flange.
 - d. Slide the upper back vent into the opening in the back plate.
 - e. Fasten 6 M6x12 screws around the inner edge of the upper back vent.

- f. Secure the M5x18 screws in the flange of the upper back vent, attaching the vent to the back plate.

Use 6 screws for the FA09 frequency converter, and 8 screws for the FA10 frequency converter.

2. To install the lower back vent, use the following steps.

- a. Slide 6 clip-on nuts over the edge of the lower vent opening in the back plate of the cabinet.
- b. Seat the clip-on nuts into the 6 holes around the opening.
- c. Affix 2 lower vent gaskets to the flange of the lower back vent, placing 1 gasket on the inner side and 1 gasket on the outer side of the flange.
- d. Slide the lower back vent into the opening in the back plate.
- e. Fasten 4 M6x12 screws around the inner edge of the lower back vent.
- f. Secure the M5x18 screws in the outer flange of the lower back vent, attaching the vent to the back plate.

Use 6 screws for the FA09 frequency converter, and 8 screws for the FA10 frequency converter.

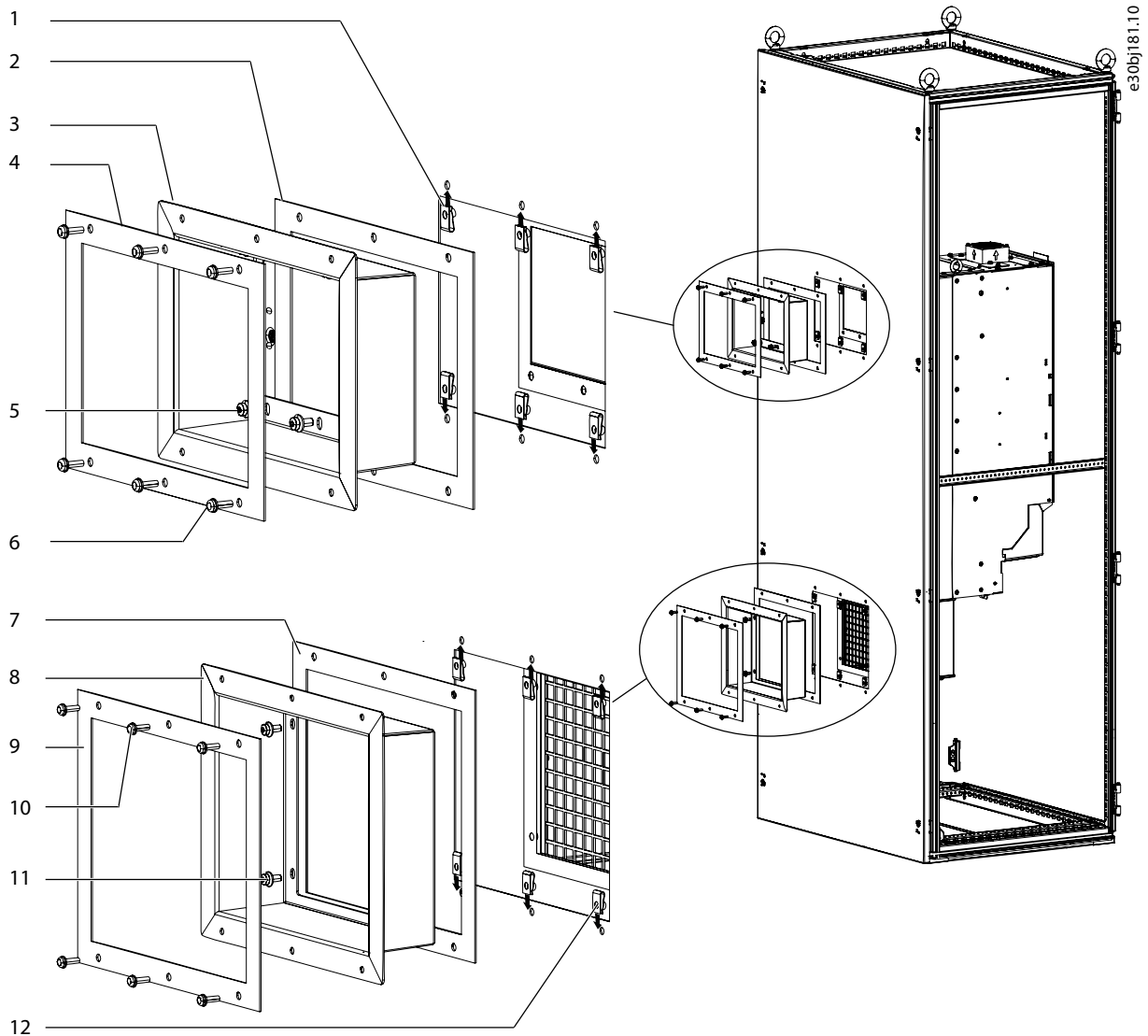

Illustration 11: Installation of Upper and Lower Back Vents

1	Clip-on nut	7	Lower vent gasket (inner)
2	Upper vent gasket (inner)	8	Lower back vent
3	Upper back vent	9	Lower vent gasket (outer)
4	Upper vent gasket (outer)	10	M5x18 screw
5	M6x12 screw	11	M6x12 screw
6	M5x18 screw	12	Clip-on nut

Danfoss A/S
Ulsnaes 1
DK-6300 Graasten
danfossdrives.com

Any information, including, but not limited to information on selection of product, its application or use, product design, weight, dimensions, capacity or any other technical data in product manuals, catalogues descriptions, advertisements, etc. and whether made available in writing, orally, electronically, online or via download, shall be considered informative, and is only binding if and to the extent, explicit reference is made in a quotation or order confirmation. Danfoss cannot accept any responsibility for possible errors in catalogues, brochures, videos and other material.
Danfoss reserves the right to alter its products without notice. This also applies to products ordered but not delivered provided that such alterations can be made without changes to form, fit or function of the product.
All trademarks in this material are property of Danfoss A/S or Danfoss group companies. Danfoss and the Danfoss logo are trademarks of Danfoss A/S. All rights reserved.

