

# In-back/Out-top Cooling Kit for FA09-FA10 iC7 Series Frequency Converters

## 1 Overview

### 1.1 Description

The in-back/out-top cooling kit fits FA09 and FA10 frequency converters mounted in Rittal TS8 and VX25 cabinets. When the kit is installed, air flows into the lower back duct and out through the top of the drive. See [Illustration 1](#).

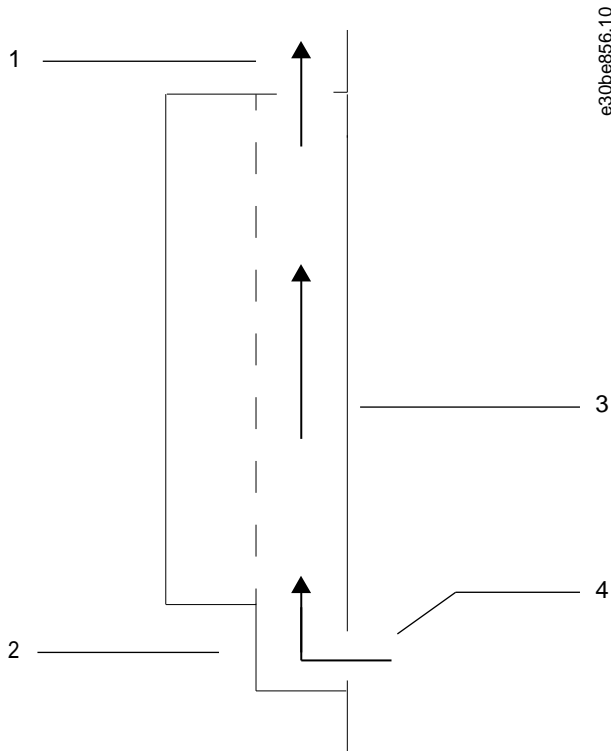

Illustration 1: Direction of Airflow with the Kit Installed

1	Top duct (exhaust)	3	Airflow direction
2	Cooling back channel	4	Lower duct (intake)

### 1.2 Kit Numbers

Use these instructions with the following kits.

Table 1: Kit Numbers for In-back/Out-top Cooling Kits

Kit number	Kit description
176F4042	In-back/out-top cooling kit for FA09 frequency converters
176F4043	In-back/out-top cooling kit for FA10 frequency converters

### 1.3 Items Supplied

The kit contains the following parts:

Table 2: Contents of In-back/Out-top Cooling Kit

Item	Quantity
Strip gasket	1
Cutout gasket	1
Ribbed EPDM rubber seal	1
Telescopic top duct assembly	1
Lower back vent	1
Lower vent gasket	2
Clip-on nut	6
M5x18 screw	10
M6x12 screw	4
Mounting plate gasket	2
Seal plate gasket	2
Seal plate	2
Lower duct frame	1
Front cover, lower duct	1
Front gasket, lower duct	1
Top gasket, lower duct	1
Grill gasket, lower duct	1
Back grill, lower duct	1
Side gasket, lower duct	2
Base cover, lower duct	1
Base gasket, lower duct	1
M10x30 screw	4
M5x10 taptite screw	4
M5x12 screw	7

## 2 Installation

### 2.1 Safety Information

#### NOTICE

##### QUALIFIED PERSONNEL

Only qualified personnel are allowed to install the parts described in these installation instructions.

- Disassembly and reassembly of the frequency converter must be done in accordance with the corresponding service guide.
- Use the standard fastener torque values from the service guide, unless the torque value is specified in these instructions.

#### ⚠ WARNING ⚠

##### ELECTRICAL SHOCK HAZARD

The frequency converter contains dangerous voltages when connected to mains voltage. Improper installation, and installing or servicing with power connected, can cause death, serious injury, or equipment failure.

- Only use qualified electricians for the installation.
- Disconnect the frequency converter from all power sources before installation or service.
- Treat the frequency converter as live whenever the mains voltage is connected.
- Follow the guidelines in these instructions and local electrical safety regulations.

#### ⚠ WARNING ⚠

##### DISCHARGE TIME (20 MINUTES)

The frequency converter contains DC-link capacitors, which can remain charged even when the frequency converter is not powered. High voltage can be present even when the warning indicator lights are off.

Failure to wait 20 minutes after power has been removed before performing service or repair work can result in death or serious injury.

- Stop the motor.
- Disconnect AC mains, permanent magnet type motors, and remote DC-link supplies, including battery backups, UPS, and DC-link connections to other frequency converters.
- Wait 20 minutes for the capacitors to discharge fully before performing any service or repair work.
- To verify full discharge, measure the voltage level.

#### NOTICE

##### ELECTROSTATIC DISCHARGE

Electrostatic discharge can damage components.

- Ensure discharge before touching internal frequency converter components, for example by touching a grounded, conductive surface or by wearing a grounded armband.

### 2.2 Installation Overview

#### NOTICE

##### APPLYING GASKETS

This kit contains self-adhesive gaskets to ensure a proper seal between metal parts.

- Before affixing a gasket, check that the part matches the gasket and that no holes are covered.

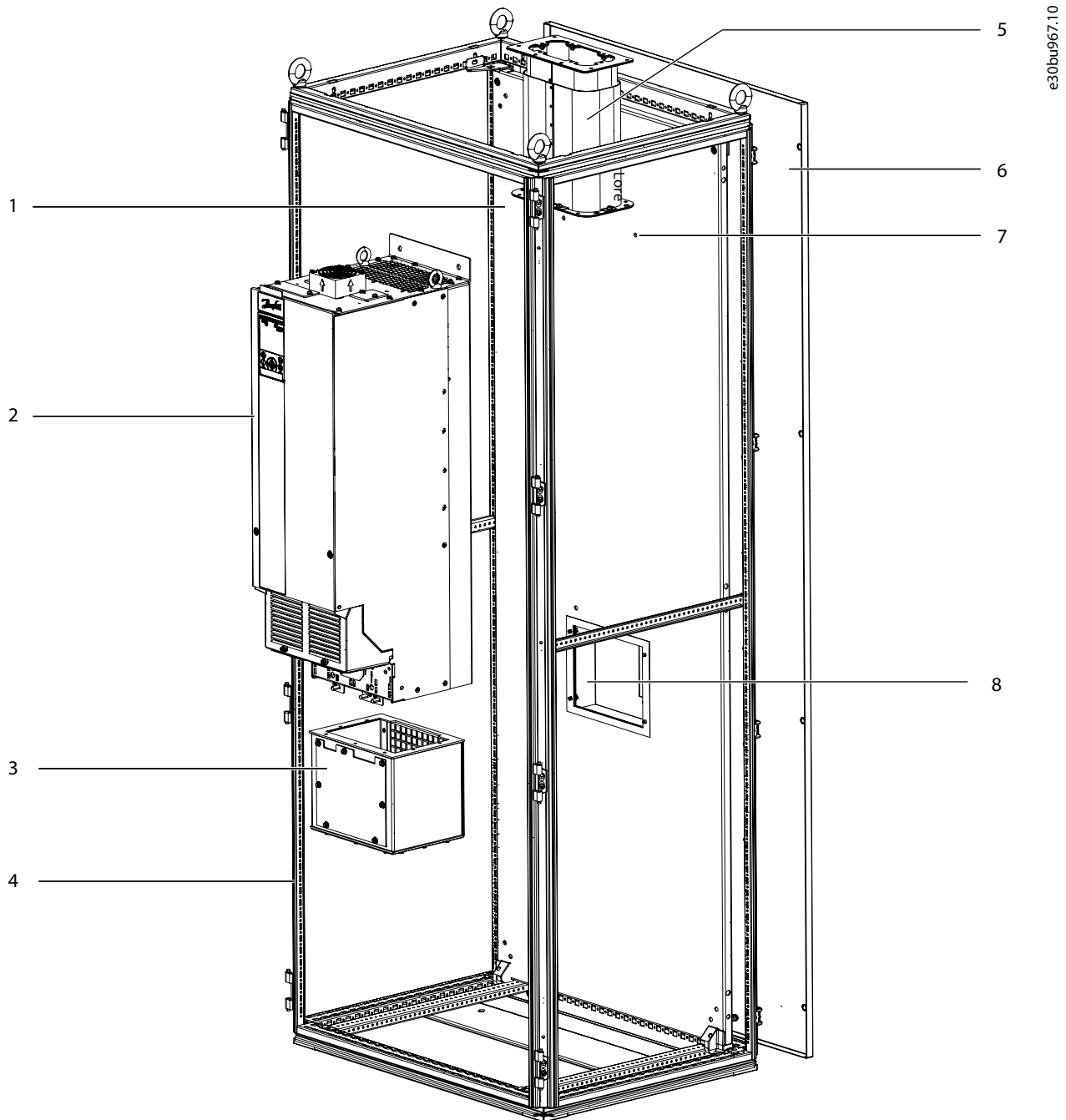

Illustration 2: Overview of In-back/Out-top; Cooling Kit

1	Mounting plate	5	Top duct assembly
2	Frequency converter	6	Backplate
3	Bottom duct assembly	7	Mounting hole
4	Rittal cabinet	8	Back vent

### 2.3 Creating a Vent Opening in the Top Plate

To create a vent opening in the cabinet top plate, use the following steps. Use the dimensions in [Illustration 3](#) for the FA09 top plate, and [Illustration 4](#) for the FA10 top plate.

#### Procedure

1. Cut out the vent opening in the Rittal cabinet top plate using the dimensions in the template.

The opening must match the top duct opening.

2. Drill 6 screw holes (4 mm) around the vent opening using the dimensions in the template.

The holes must match the holes in the upper flange of the top duct.

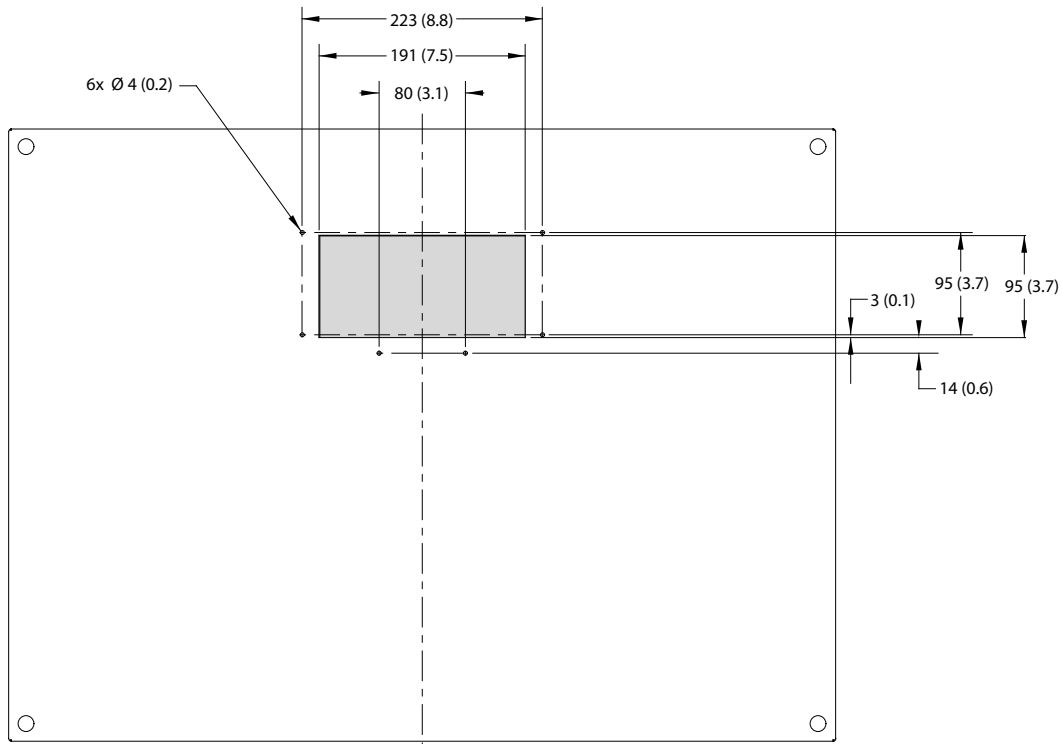

e30bj065.10

Illustration 3: FA09 Rittal Cabinet Top Plate Template

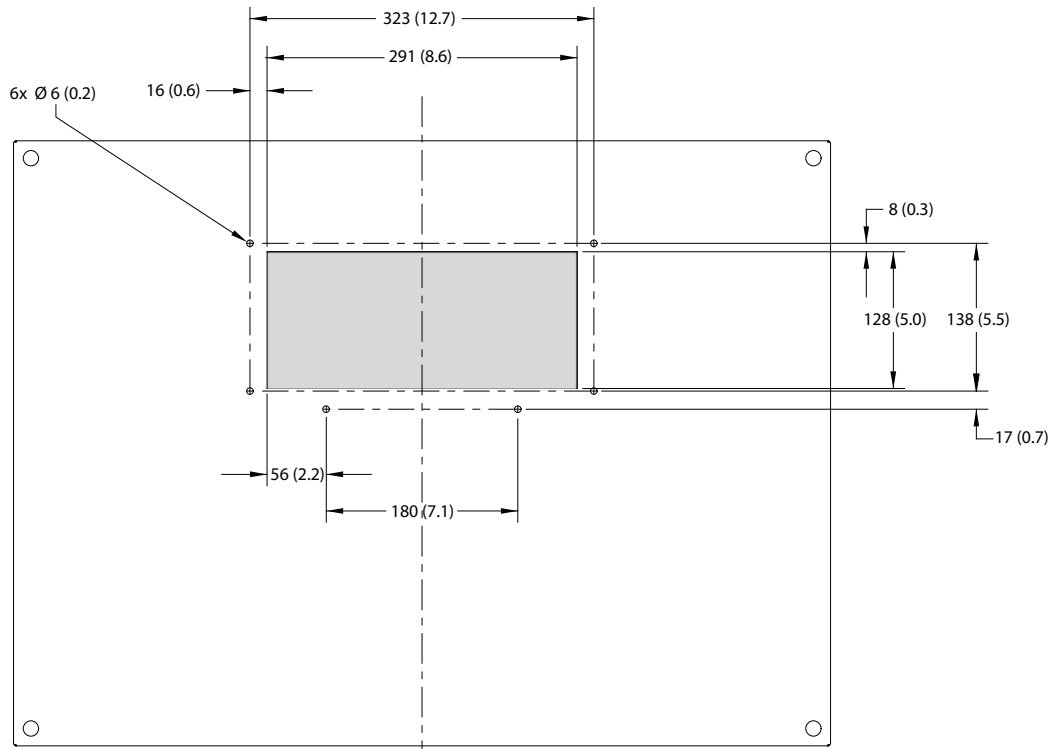

e30bj068.10

Illustration 4: FA10 Rittal Cabinet Top Plate Template

## 2.4 Preparing the Mounting Plate

To create mounting holes and a vent opening in the mounting plate, use the following steps. Use the dimensions in [Illustration 5](#) for FA09 frequency converters, and [Illustration 6](#) for FA10 frequency converters.

### Procedure

1. Drill 4 mounting holes in the mounting plate using the dimensions in the template.

The holes must match the holes in the frequency converter.

2. Insert 4 M10 pem nuts (not supplied) in the mounting holes.
3. Cut out the vent opening in the mounting plate using the dimensions in the template.

The opening must match the opening in the lower duct.

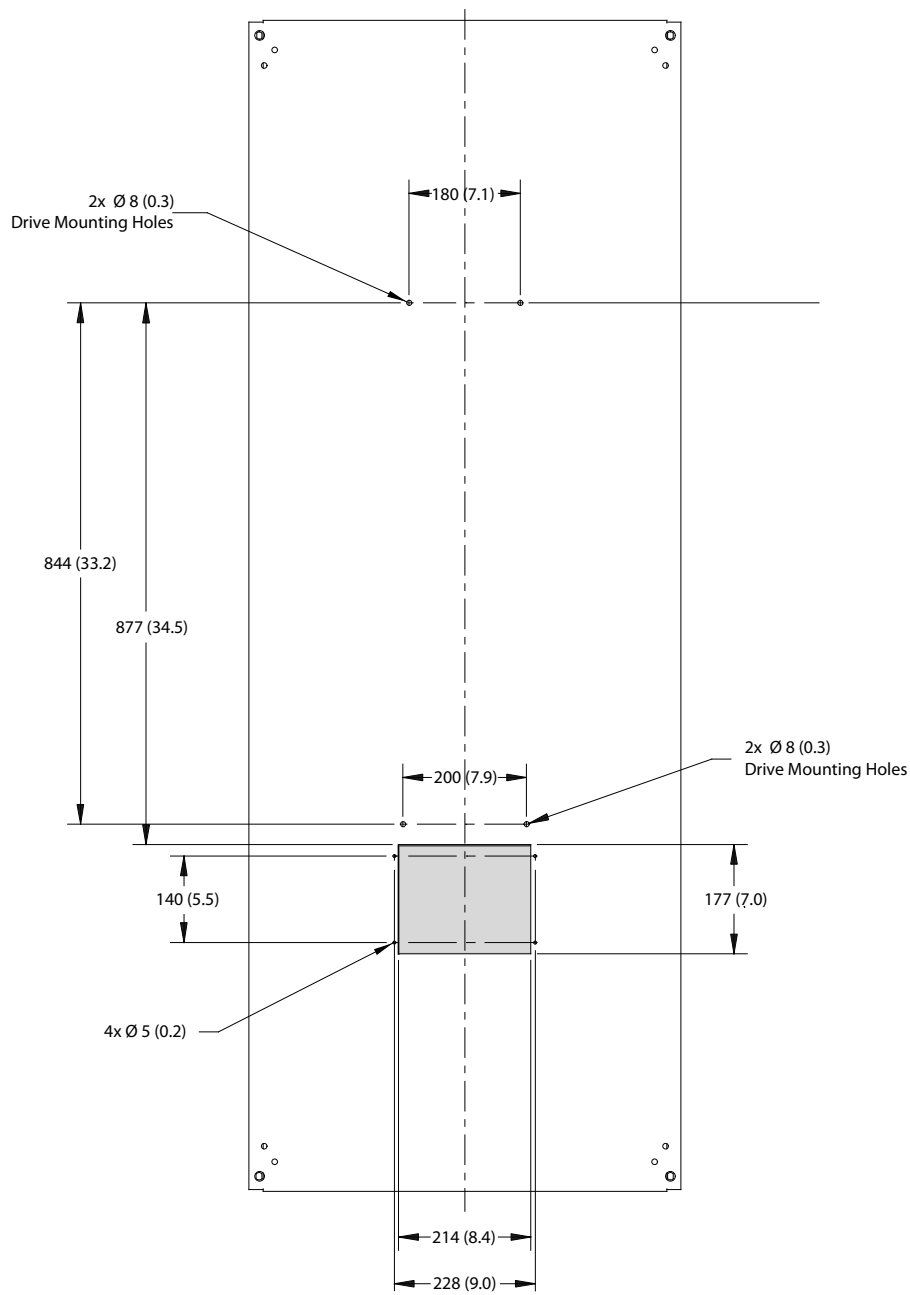

e30bj186.10

Illustration 5: FA09 Mounting Plate Template for In-back/Out-top Cooling

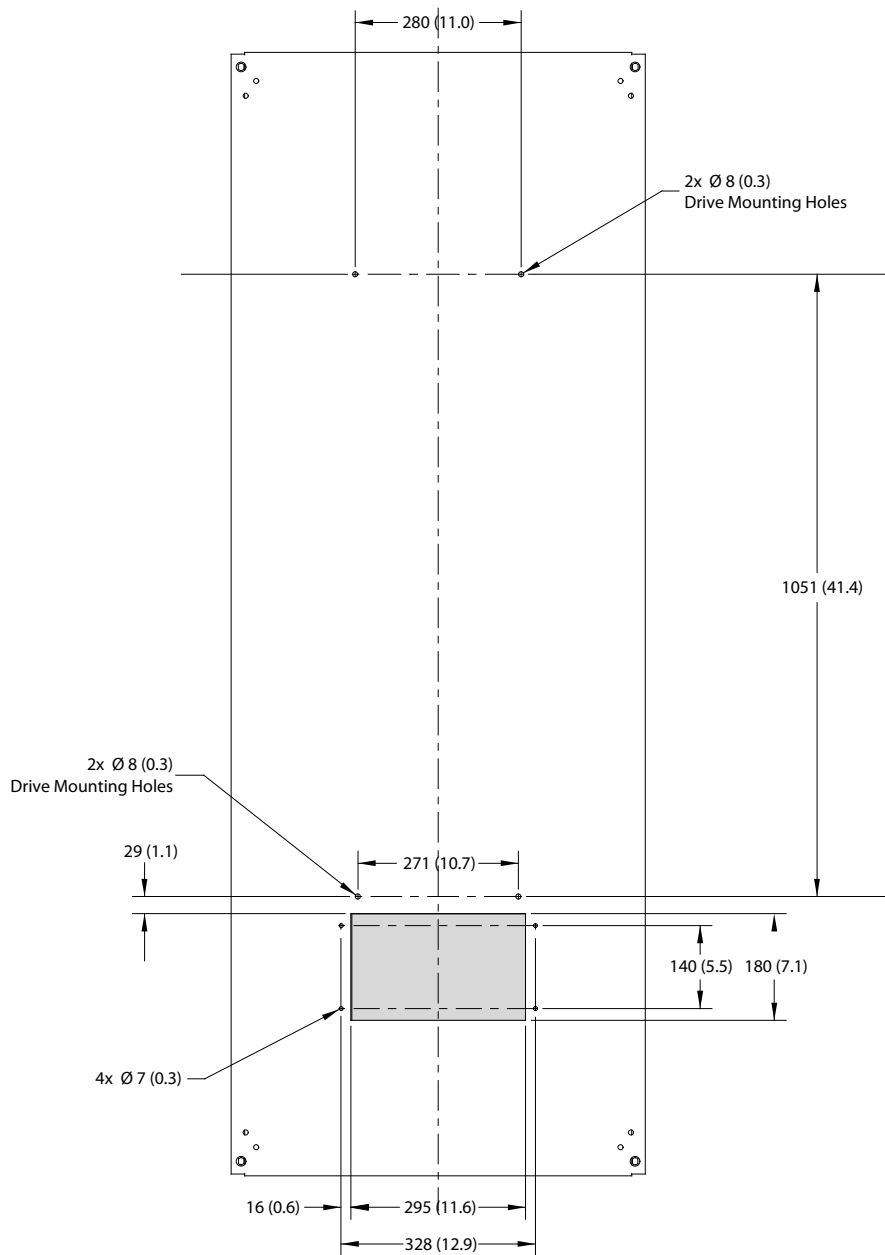

Illustration 6: FA10 Mounting Plate Template for In-back/Out-top Cooling

## 2.5 Preparing the Back Plate

To create a vent opening in the cabinet back plate to match the opening in the mounting plate, use the following steps. Use the dimensions in [Illustration 7](#) for FA09 frequency converters, and [Illustration 8](#) for FA10 frequency converters.

### Procedure

1. Cut out the vent opening in the cabinet back plate using the dimensions in the template.

The opening must match the mounting plate opening.

2. Drill screw holes (6 mm) around the vent opening using the dimensions in the template.

The FA09 requires 6 holes around the vent opening, and the FA10 requires 8 holes around the opening. The holes must align with the holes in the outer flanges of the duct.



Example

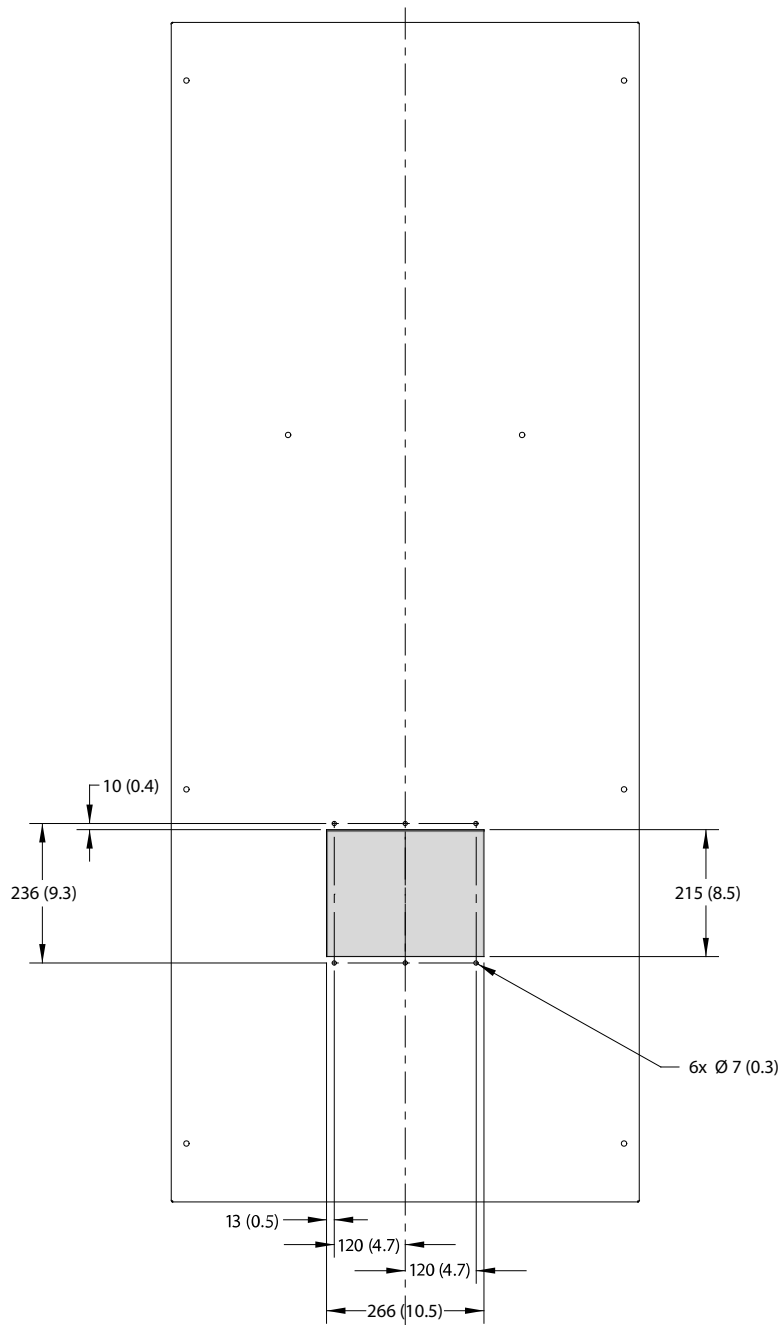

e30bj188.10

Illustration 7: FA09 Cabinet Back Plate Template for In-back/Out-top Cooling

e30bj189.10

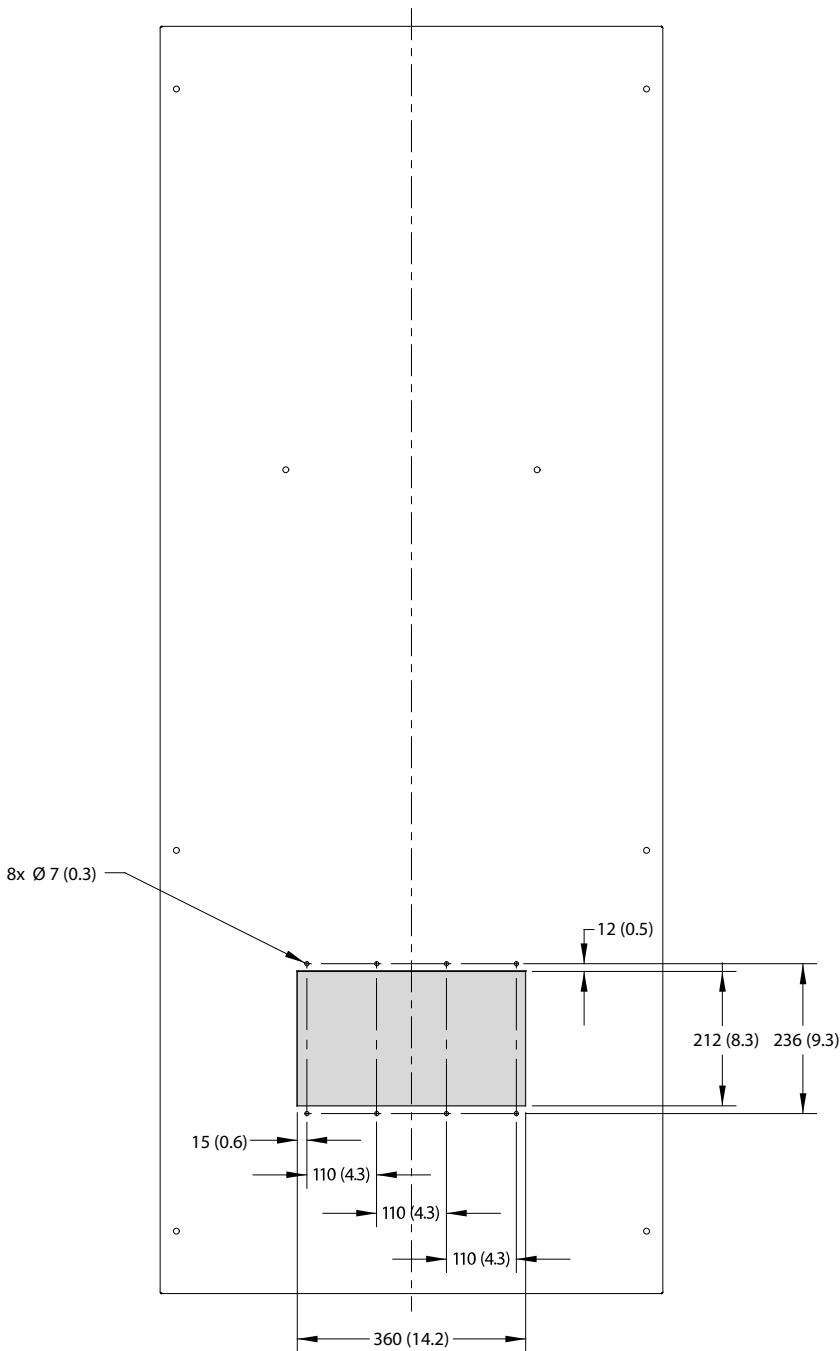

Illustration 8: FA10 Cabinet Back Plate Template for In-back/Out-top Cooling

## 2.6 Mounting the Frequency Converter

To install the mounting plate and frequency converter in the Rittal cabinet, use the following steps. Refer to [Illustration 9](#).

### Procedure

1. Remove the backing paper from the 2 self-adhesive mounting plate gaskets.
2. Affix the gaskets around the lower vent opening, 1 on each side of the mounting plate.
3. Attach the mounting plate to the cabinet rails, making sure that the pem nuts face the front of the cabinet.
4. Remove the backing paper from the 2 seal plate gaskets, and affix the gaskets to the seal plates, 1 per plate.
5. Fasten 2 M10x30 screws through the seal plates, 1 per plate, and into the M10 nuts at the lower end of the mounting plate.

Make sure that the screws are secure. The base of the frequency converter rests on the screws.

6. Slightly lean the top of the frequency converter forward and set the notches in the base onto the 2 screws.

7. Slowly push the top of the frequency converter back against the mounting plate until the top 2 pem nuts line up with the holes in the frequency converter.

Secure the top of the frequency converter using 2 M10x30 screws. Torque all fasteners to 19 Nm (170 in-lb).

Example

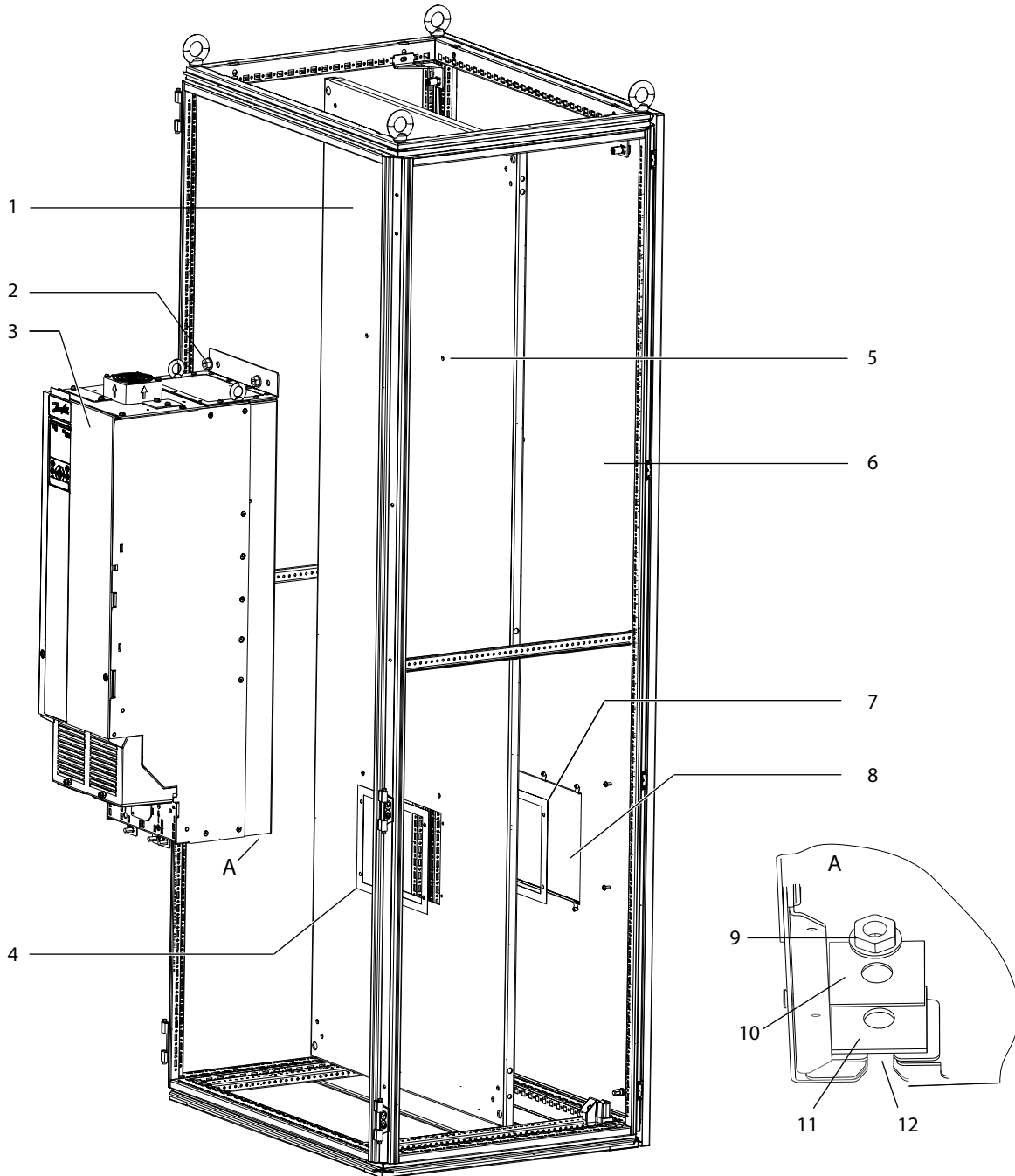

Illustration 9: Installation of the Frequency Converter in the Cabinet

1	Mounting plate	7	Mounting plate gasket (back)
2	M10x30 screw	8	Back vent opening
3	Frequency converter	9	M10 nut
4	Mounting plate gasket (front)	10	Seal plate gasket
5	Mounting holes	11	Seal plate
6	Cabinet back plate	12	Notch in lower edge of frequency converter

### 2.7 Assembling the Top Duct

The top duct is a telescopic duct that collapse to simplify installation. To assemble the duct before installation, use the following steps. Refer to [Illustration 10](#).

#### Procedure

- Cut the strip of ribbed EPDM rubber seal into 2 pieces. Use the following measurements:
  - a. For FA09 frequency converters, cut 2 strips of 581 mm (22.9 in).
  - b. For FA10 frequency converters, cut 2 strips of 849 mm (33.4 in).
- Peel the paper off the self-adhesive seals. Place 1 strip on the outside bottom edge of the inner sleeve of the duct, and 1 strip on the upper inside edge of the outer sleeve of the duct.
- With the rubber seal in place, carefully slide the inner sleeve of the duct into the outer sleeve.

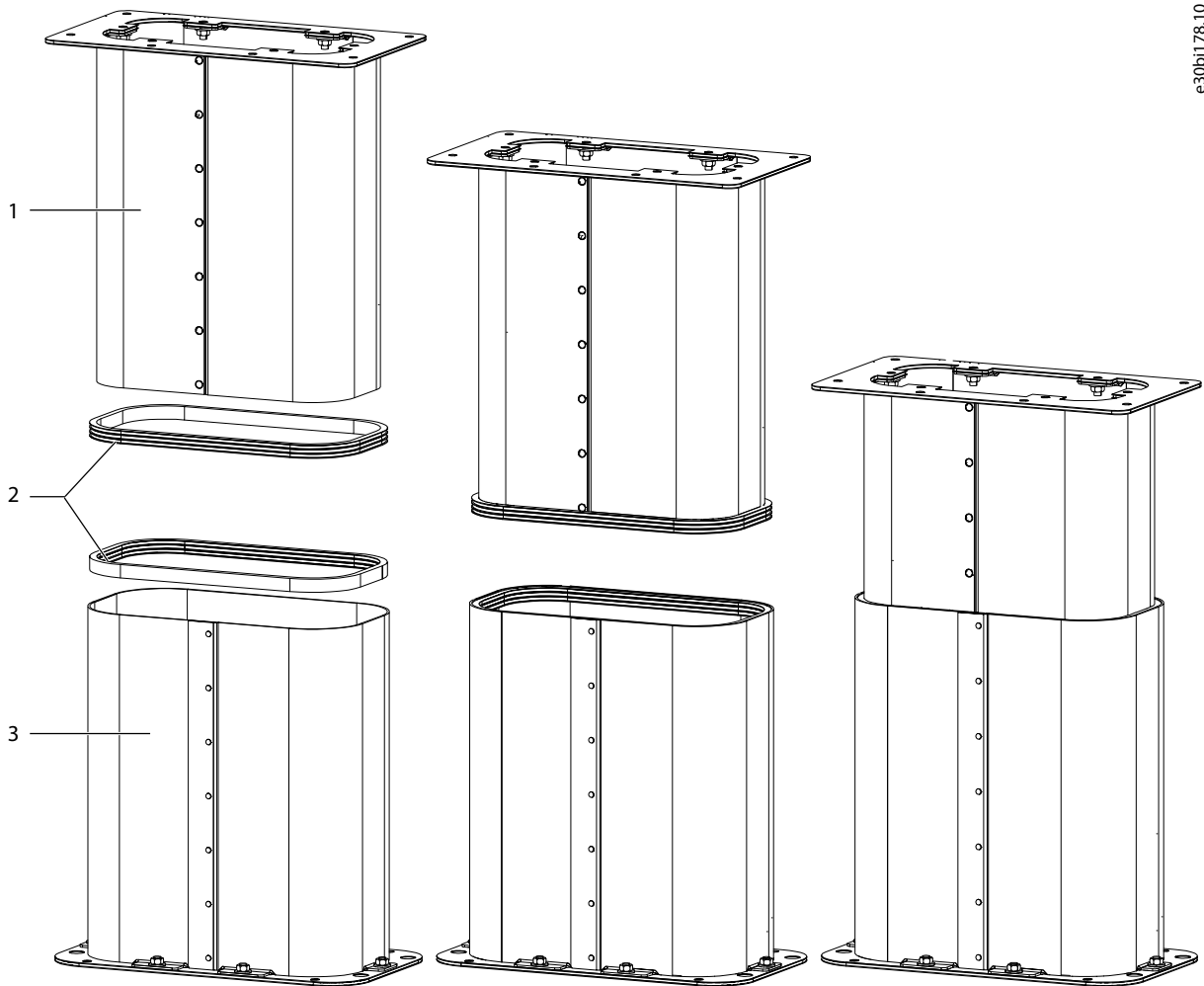

Illustration 10: Assembly of Telescopic Ducts

e30bj178.10

1	Inner sleeve of duct	3	Outer sleeve of duct
2	Ribbed EPDM rubber seal		

## 2.8 Installing the Top Duct

Attach the top telescopic duct between the top of the frequency converter and the cabinet using the following steps. Refer to [Illustration 11](#) (The top plate of the cabinet is removed from the illustration for visibility of parts).

### Procedure

1. Collapse the top duct and position it over the vent in the top of the frequency converter.
2. Secure the duct to the top of the frequency converter with 4 M5x18 screws.
3. Extend the telescopic duct upward until the upper flange of the duct is positioned against the underside of the cabinet top plate.
4. Secure the duct to the top plate with 6 M5x10 screws (T25) through the upper flange of the duct.

Torque fasteners to 2.3 Nm (20 in-lb).

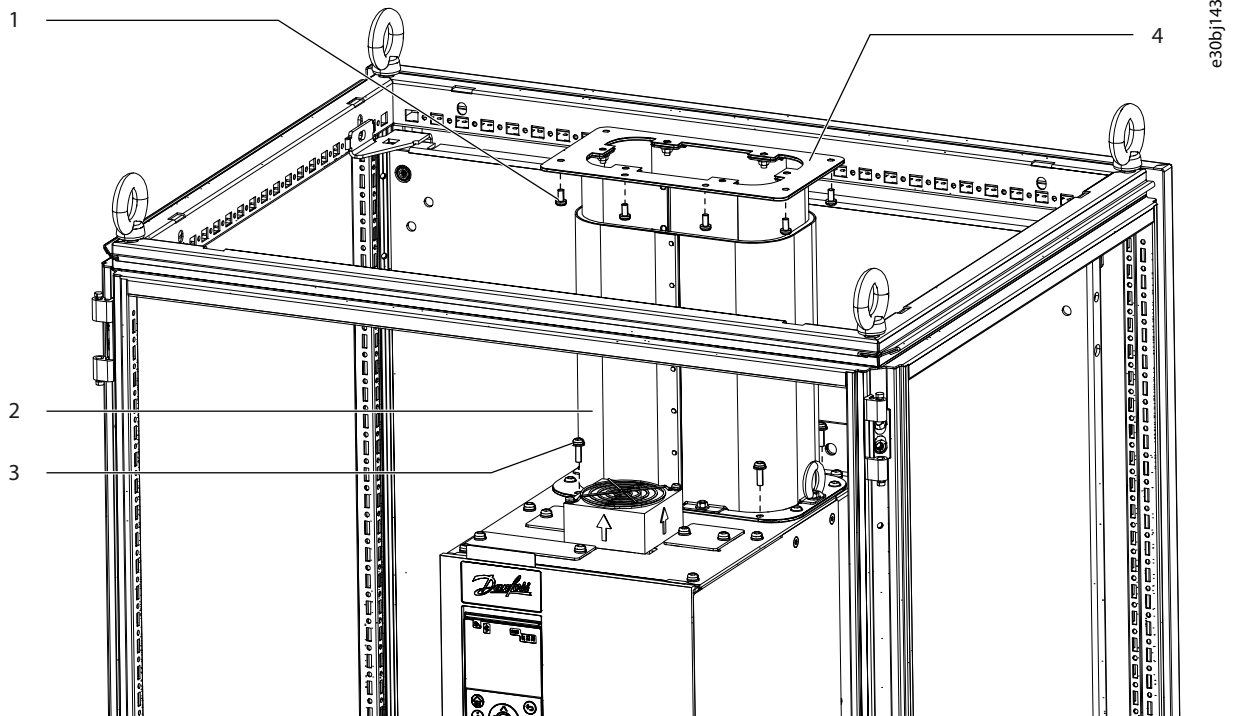

Illustration 11: Installation of the Top Duct

1	M5x10 screw	3	M5x18 screw
2	Telescopic top duct	4	Upper flange of duct

## 2.9 Assembling the Lower Duct

To assemble the lower duct, use the following steps. Refer to [Illustration 12](#).

### Procedure

1. Peel the paper from the side gaskets, and press to attach the gaskets to the duct frame.

Align the holes in the side gaskets with the holes in the left and right sides of the back opening of the duct frame.

2. Place the grill over the left and right gaskets, with the threaded studs in the grill going through the middle holes in the gasket and into the duct frame.

- Secure the grill to the duct frame using 1 M5 nut on each stud.

Torque to 2.3 Nm (20 in-lb).

- Affix the grill gasket to the outer side of the back grill.
- Affix the duct base gasket to the duct base cover.
- Secure the base cover to the underside of the duct frame with 12 M5 nuts (for FA09) or 14 M5 nuts (for FA10).

Torque to 2.3 Nm (20 in-lb).

- Place the front gasket on the front side of the duct frame, making sure the holes in the frame and gasket align.
- Affix the top gasket to the top of the duct frame.

Wait to attach the front duct cover until the lower duct assembly is installed in the cabinet.

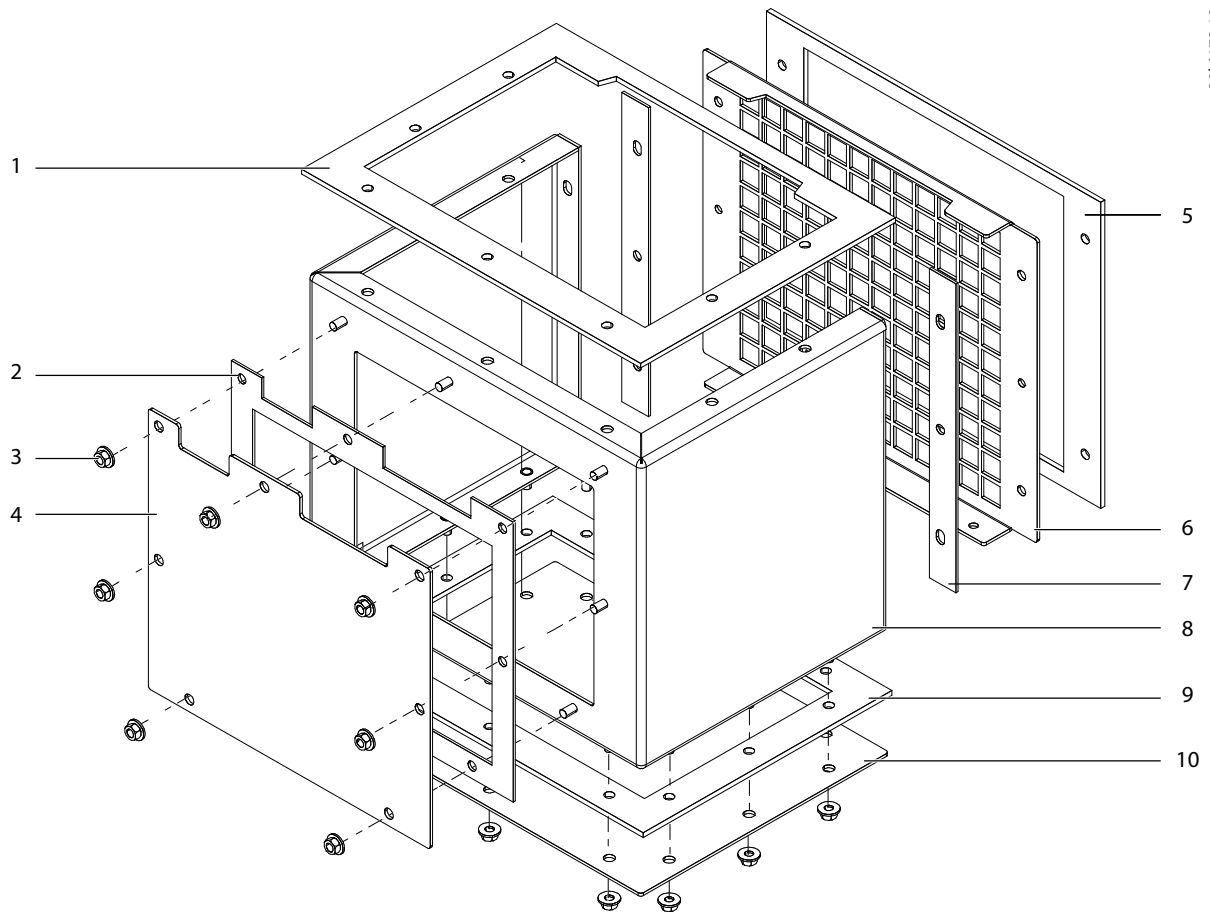

e30bj172.10

Illustration 12: Assembly of Lower Duct

1	Top gasket	6	Back grill
2	Front gasket	7	Side gaskets, left and right
3	M5 nut	8	Duct frame
4	Front cover	9	Base gasket
5	Grill gasket	10	Duct base cover

## 2.10 Installing the Lower Duct

To attach the lower duct to the frequency converter, use the following steps.

### Procedure

1. Place the strip gasket over the 2 slots at the bottom back of the frequency converter.
2. Remove the cover and gasket from the bottom of the frequency converter by removing 7 screws.

Retain the screws, but discard the cover and gasket.

3. Secure the top flange of the duct to the bottom of the frequency converter using the screws removed in step 2.

Refer to [Illustration 13](#). Torque screws to 2.3 Nm (20 in-lb).

4. Attach the front duct cover.

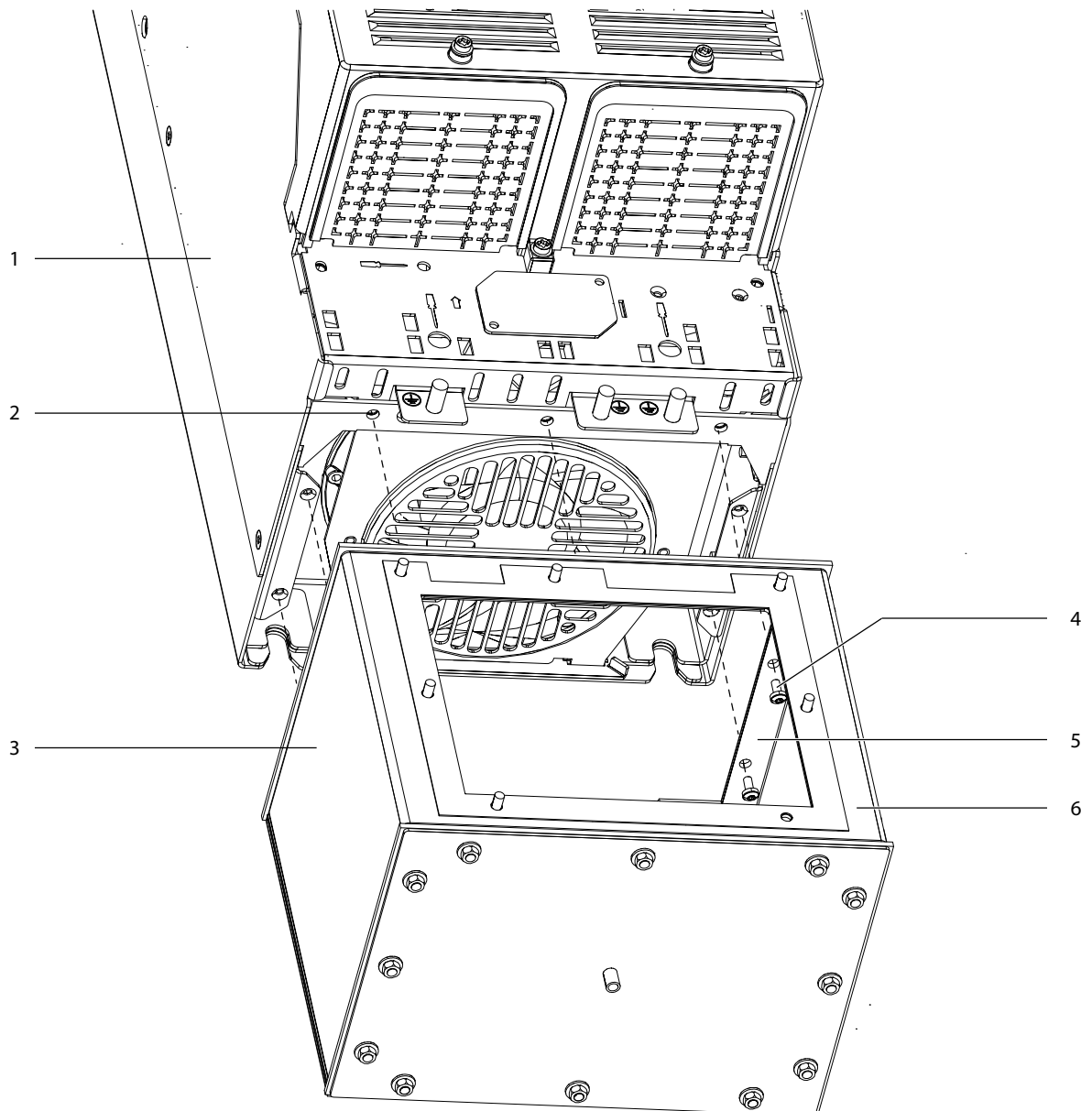

e30bj173.10

Illustration 13: Installation of Lower Duct

1	Frequency converter	4	Screw
2	Holes for attaching duct	5	Top flange of duct
3	Lower duct	6	Front of duct

## 2.11 Installing the Back Vent

To install the back vent, use the following steps. Refer to [Illustration 14](#).

### Procedure

1. Slide 6 clip-on nuts over the edge of the vent opening in the back plate of the cabinet.
2. Seat the clip-on nuts into the 6 holes around the opening.
3. Affix 2 back vent gaskets to the flange of the back vent, placing 1 gasket on the inner side and 1 gasket on the outer side of the flange.
4. Slide the back vent into the opening in the back plate.
5. Fasten 4 M6x12 screws around the inner edge of the back vent.
6. Secure 6 M5x18 screws in the outer flange of the back vent, attaching the vent to the back plate.

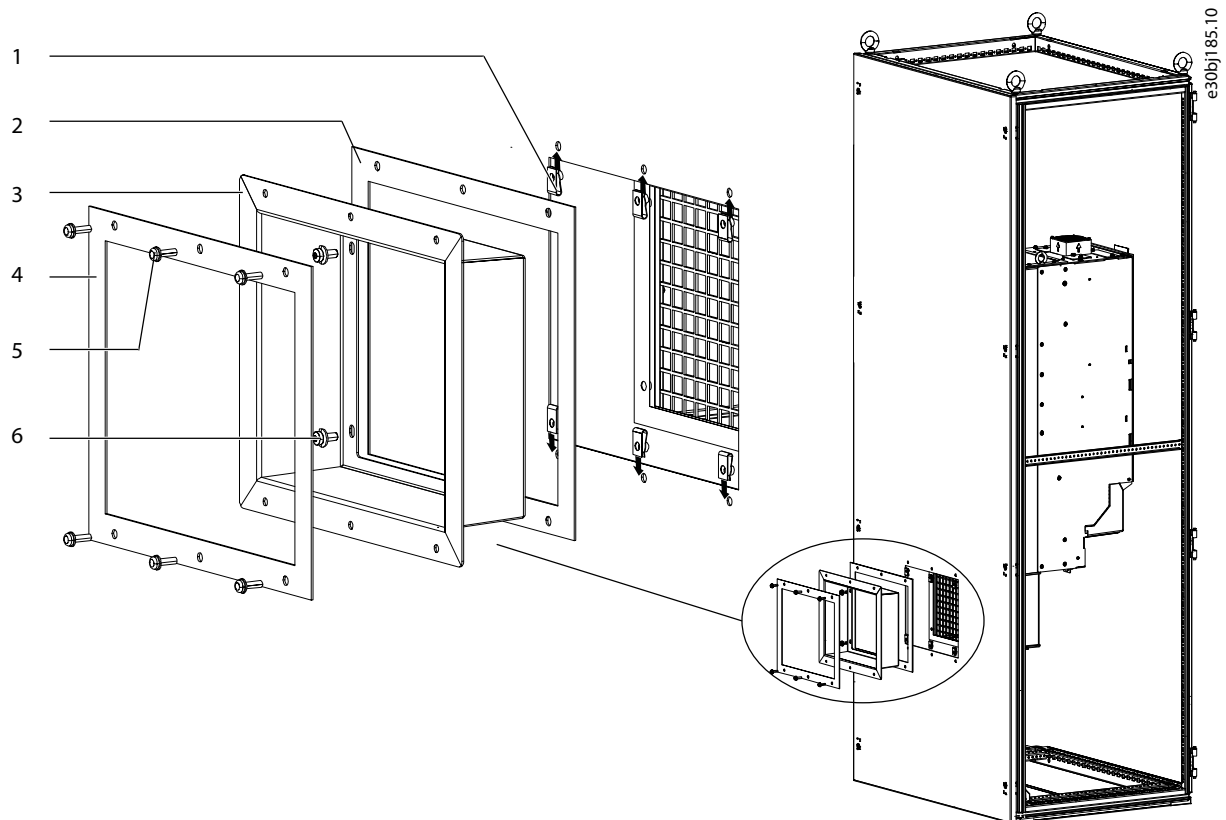

Illustration 14: Installation of the Back Vent

1	Clip-on nut	4	Back vent gasket (outer)
2	Back vent gasket (inner)	5	M5x18 screw
3	Back vent	6	M6x12 screw





**Danfoss A/S**  
Ulsnaes 1  
DK-6300 Graasten  
drives.danfoss.com

Any information, including, but not limited to information on selection of product, its application or use, product design, weight, dimensions, capacity or any other technical data in product manuals, catalogues descriptions, advertisements, etc. and whether made available in writing, orally, electronically, online or via download, shall be considered informative, and is only binding if and to the extent, explicit reference is made in a quotation or order confirmation. Danfoss cannot accept any responsibility for possible errors in catalogues, brochures, videos and other material. Danfoss reserves the right to alter its products without notice. This also applies to products ordered but not delivered provided that such alterations can be made without changes to form, fit or function of the product. All trademarks in this material are property of Danfoss A/S or Danfoss group companies. Danfoss and the Danfoss logo are trademarks of Danfoss A/S. All rights reserved.

