

In-back/Out-top Cooling Kit for FA11-FA12

iC7 Series Frequency Converters

1 Overview

1.1 Description

The in-back/out-top cooling kit fits FA11 and FA12 frequency converters mounted in Rittal TS8 cabinets with widths of 600 mm (24 in) or 800 mm (32 in). When the kit is installed, air flows into the back duct and out through the top duct of the frequency converter. See [Illustration 1](#).

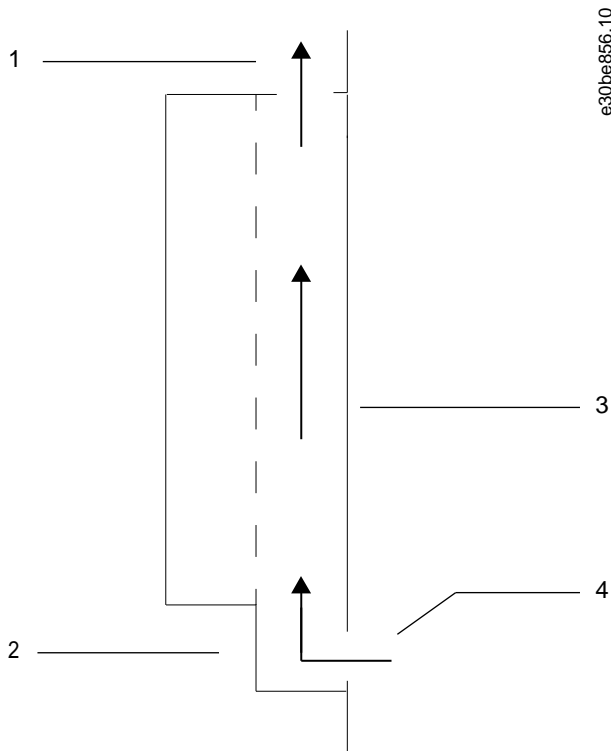

Illustration 1: Direction of Airflow with Kit Installed

1	Top duct (exhaust)	3	Airflow direction
2	Cooling back channel	4	Bottom duct (intake)

1.2 Kit Numbers

Use these instructions with the following kits.

Table 1: In-back/Out-top Cooling Kits

Number	Kit description
176F4061	In-back/out-top cooling kit for FA11 frequency converters
176F4062	In-back/out-top cooling kit for FA12 frequency converters

1.3 Items Supplied

The following parts are contained in the kit.

Table 2: Items Supplied in In-back/Out-top Cooling Kits

Item	Quantity
Bottom cover	1
Bottom gasket	1
Telescopic top duct assembly	1
Ribbed EPDM rubber seal	1
Back duct	1
6-hole back gasket	2
8-hole back gasket	2
Clip-on nut	8
M6x12 screw	6
M5x18 screw	8
M5x14 screw	8-10
M5 hex nut	6

2 Installation

2.1 Safety Information

NOTICE

QUALIFIED PERSONNEL

Only qualified, Danfoss authorized personnel are allowed to install the parts described in these installation instructions.

- Disassembly and reassembly of the frequency converter must be done in accordance with the service guide.
- Use the standard fastener torque values from the service guide, unless the torque value is specified in these instructions.

⚠ WARNING ⚠

DISCHARGE TIME (40 MINUTES)

The frequency converter contains DC-link capacitors, which can remain charged even when the frequency converter is not powered. High voltage can be present even when the warning LED indicator lights are off. Failure to wait 40 minutes after power has been removed before performing service or repair work can result in death or serious injury.

- Stop the motor.
- Disconnect AC mains and remote DC-link power supplies, including battery back-ups, UPS, and DC-link connections to other frequency converters.
- Disconnect or lock the motor.
- Disconnect any brake option.
- Disconnect any DC connector option.
- Wait 40 minutes for the DC-link capacitors to discharge fully.
- Before performing any service or repair work, measure the voltage level to verify that the capacitors are fully discharged.

⚠ WARNING ⚠

ELECTRICAL SHOCK HAZARD

The frequency converter contains dangerous voltages when connected to mains voltage. Improper installation, and installing or servicing with power connected, can cause death, serious injury, or equipment failure.

- Only use qualified electricians for the installation.
- Disconnect the frequency converter from all power sources before installation or service.
- Treat the frequency converter as live whenever the mains voltage is connected.
- Follow the guidelines in these instructions and local electrical safety codes.

NOTICE

ELECTROSTATIC DISCHARGE

Electrostatic discharge can damage components.

- Ensure electrostatic discharge before touching internal frequency converter components, for example by touching a grounded, conductive surface or by wearing a grounded armband.

2.2 Installation Overview

NOTICE

APPLYING GASKETS

This kit contains self-adhesive gaskets to ensure a proper seal between metal parts.

- Before affixing a gasket, check that the part matches the gasket and that no holes are covered.

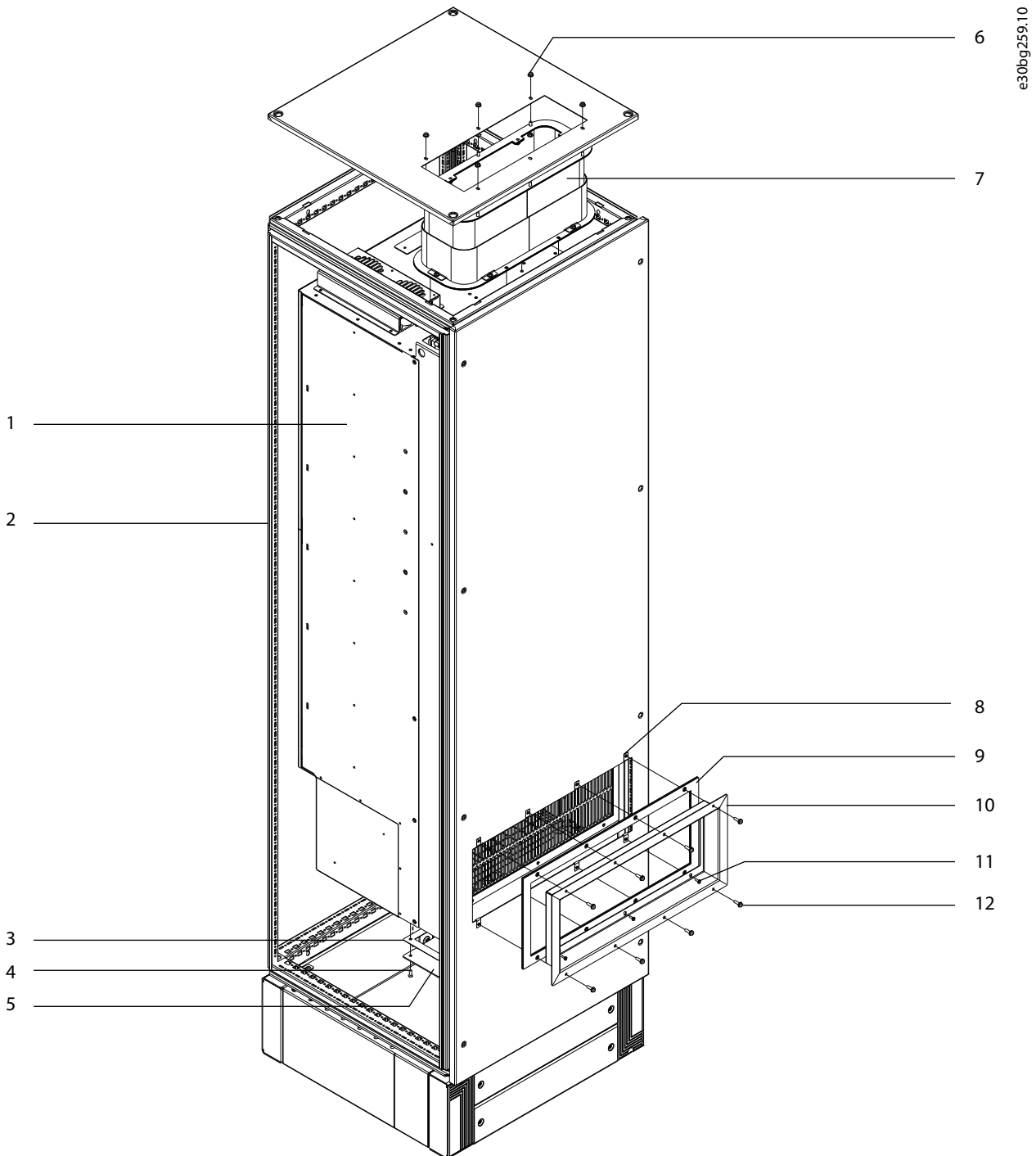

Illustration 2: Overview of In-back/Out-top Cooling Kit

1	Frequency converter	7	Top duct assembly
2	Rittal cabinet	8	Clip-on nut
3	Bottom gasket	9	Back gasket
4	M5x14 screw	10	Back duct
5	Bottom cover	11	M6x12 screw
6	M5 hex nut	12	M5x18 screw

2.3 Creating a Vent Opening in the Mounting Plate

To create mounting holes and a back vent opening in the mounting plate, use the following steps. Use the dimensions in [Illustration 3](#) for 600 mm (24 in) cabinets, or [Illustration 4](#) for 800 mm (32 in) cabinets.

Procedure

1. Drill 6 mounting holes in the back of the frequency converter using the dimensions in the template.
2. Insert 6 M10 pem self-clinching nuts (not supplied) in the mounting holes.
3. Cut out the vent opening in the mounting plate using the dimensions in the template.

The opening must match the frequency converter vent opening.

4. Drill 6 screw holes around the vent opening using the dimensions in the template.

The holes must match the holes in the inner flange of the back duct.

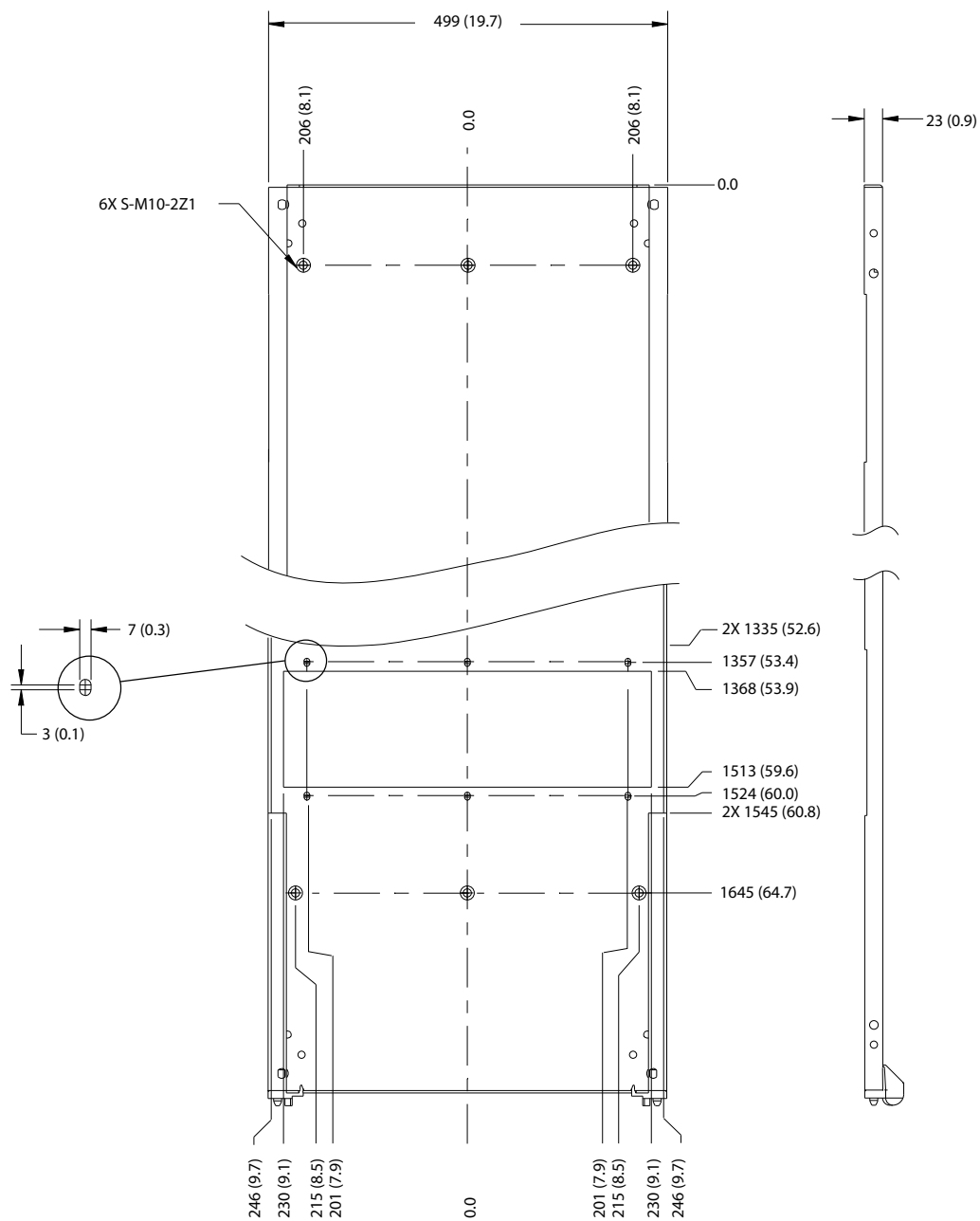

e30bg255.10

Illustration 3: Vent Dimensions for Mounting Plate in 600 mm (24 in) Cabinet

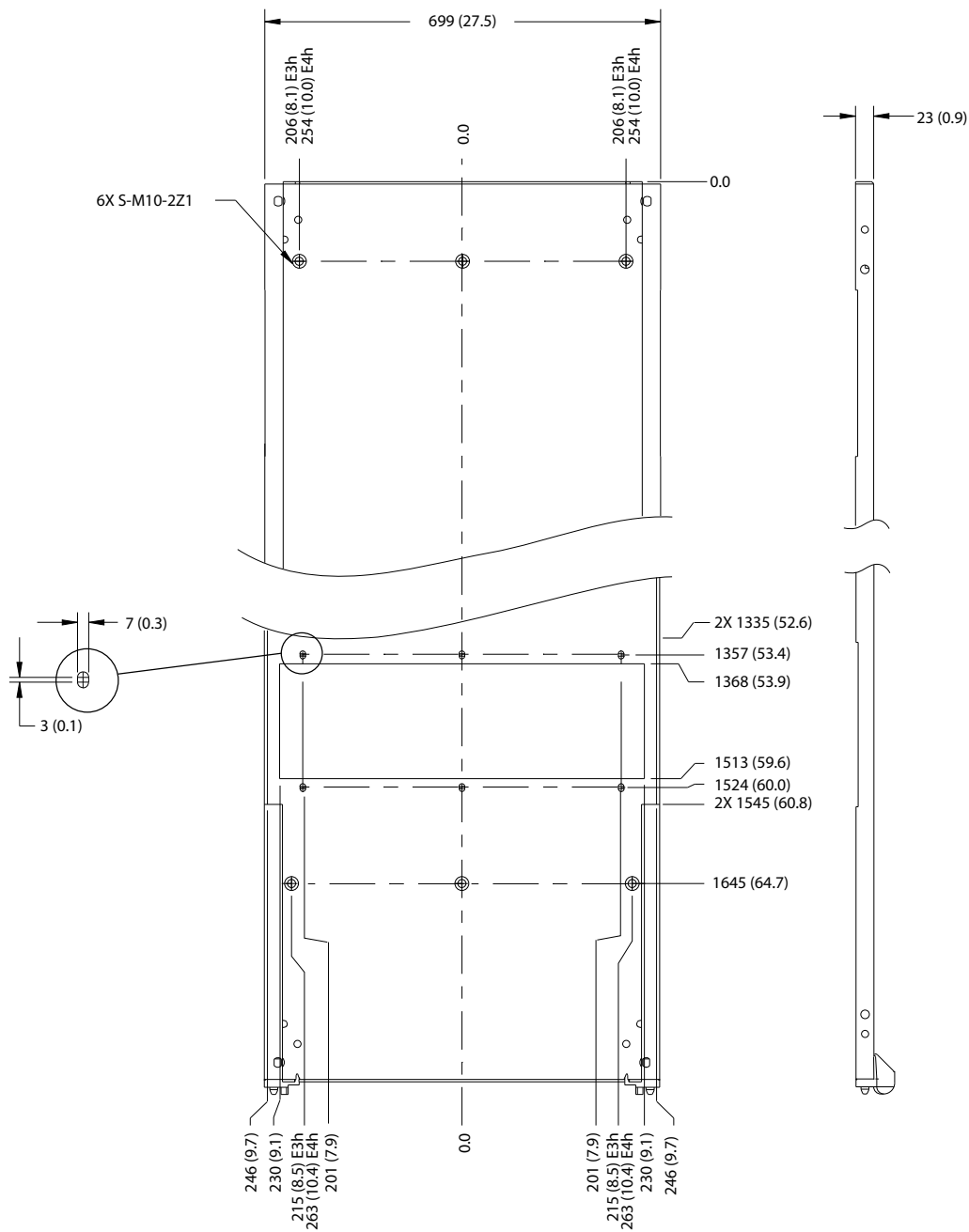

e30bg256.10

Illustration 4: Vent Dimensions for Mounting Plate in 800 mm (32 in) Cabinet

2.4 Creating a Vent Opening in the Backplate

To create a vent opening in the cabinet backplate to match the mounting plate and frequency converter vent, use the following steps. Use the dimensions in [Illustration 5](#) for 600 mm (24 in) cabinets, or [Illustration 6](#) for 800 mm (32 in) cabinets.

Procedure

1. Cut out the vent opening in the cabinet backplate using the template dimensions.

The opening must match the frequency converter vent opening.

2. Drill 8 screw holes (6 mm) around the vent opening using the dimensions in the template.

The holes must match the holes in the outer flange of the back duct.

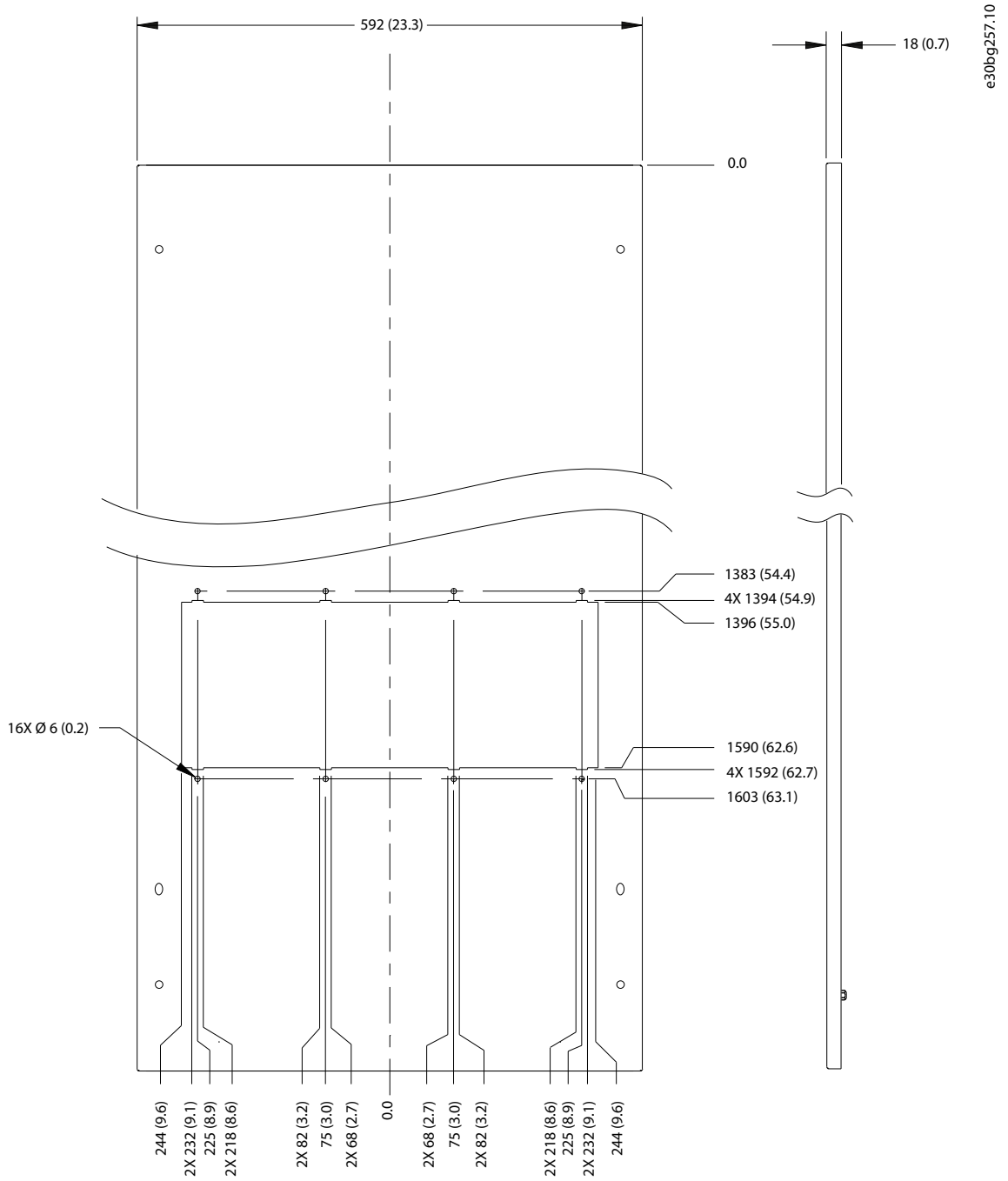

Illustration 5: Vent Dimensions for Backplate in 600 mm (24 in) Cabinet

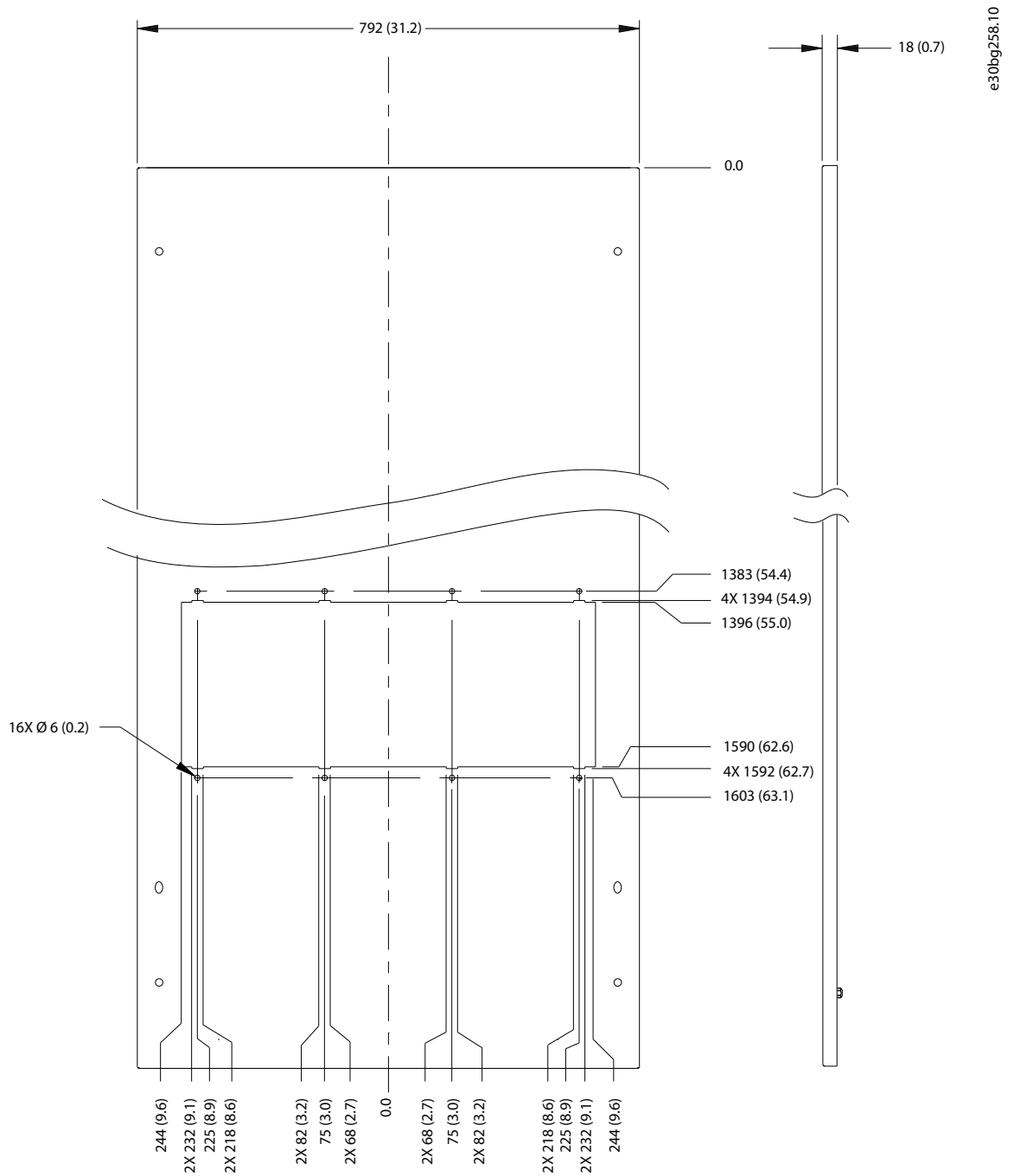

Illustration 6: Vent Dimensions for Backplate in 800 mm (32 in) Cabinet

2.5 Creating a Vent Opening in the Top Plate

To create a vent opening in the cabinet top plate, use the following steps. Refer to [Illustration 7](#) and [Illustration 8](#).

Procedure

1. Cut out the vent opening in the cabinet top plate using the dimensions in the template.

The opening must match the frequency converter vent opening.

2. Drill 6 screw holes (6 mm) around the vent opening using the dimensions in the template.

The holes must match the holes in the upper flange of the top duct.

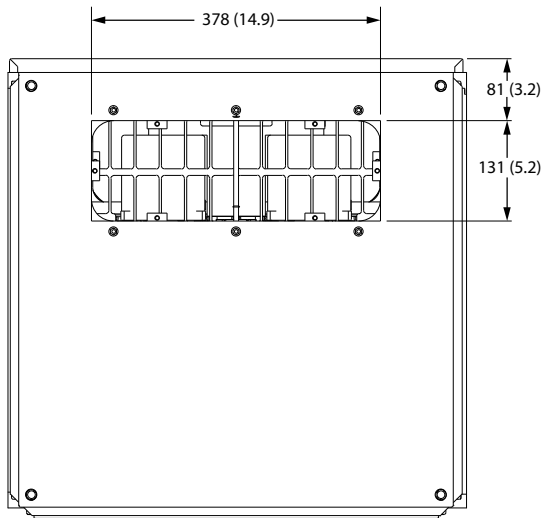

e30bg116.10

Illustration 7: Dimensions of Vent in Top of Frequency Converter

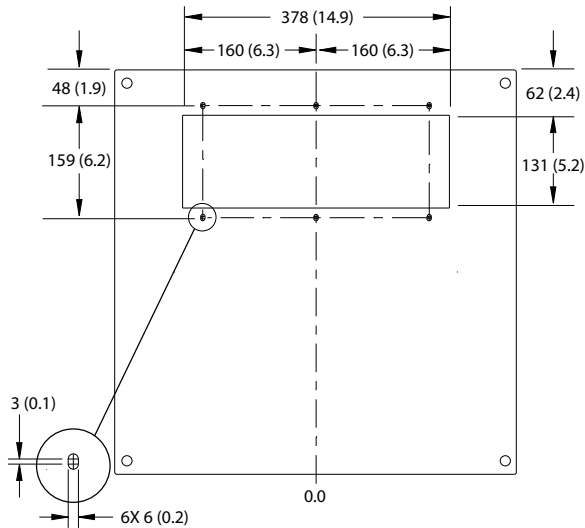

e30bg114.10

Illustration 8: Dimensions for Opening in Cabinet Top Plate

2.6 Assembling the Top Duct

The top duct is a telescopic duct that collapses to simplify installation. To assemble the duct before installation, use the following steps. Refer to [Illustration 9](#).

Procedure

1. Cut the strip of ribbed EPDM rubber seal into 2 pieces of 1027 mm (40.4 in).
2. Peel the paper off the self-adhesive seals. Place 1 strip on the outside bottom edge of the inner sleeve of the duct, and 1 strip on the upper inside edge of the outer sleeve of the duct.

- With the rubber seal in place, carefully slide the inner sleeve of the duct into the outer sleeve.

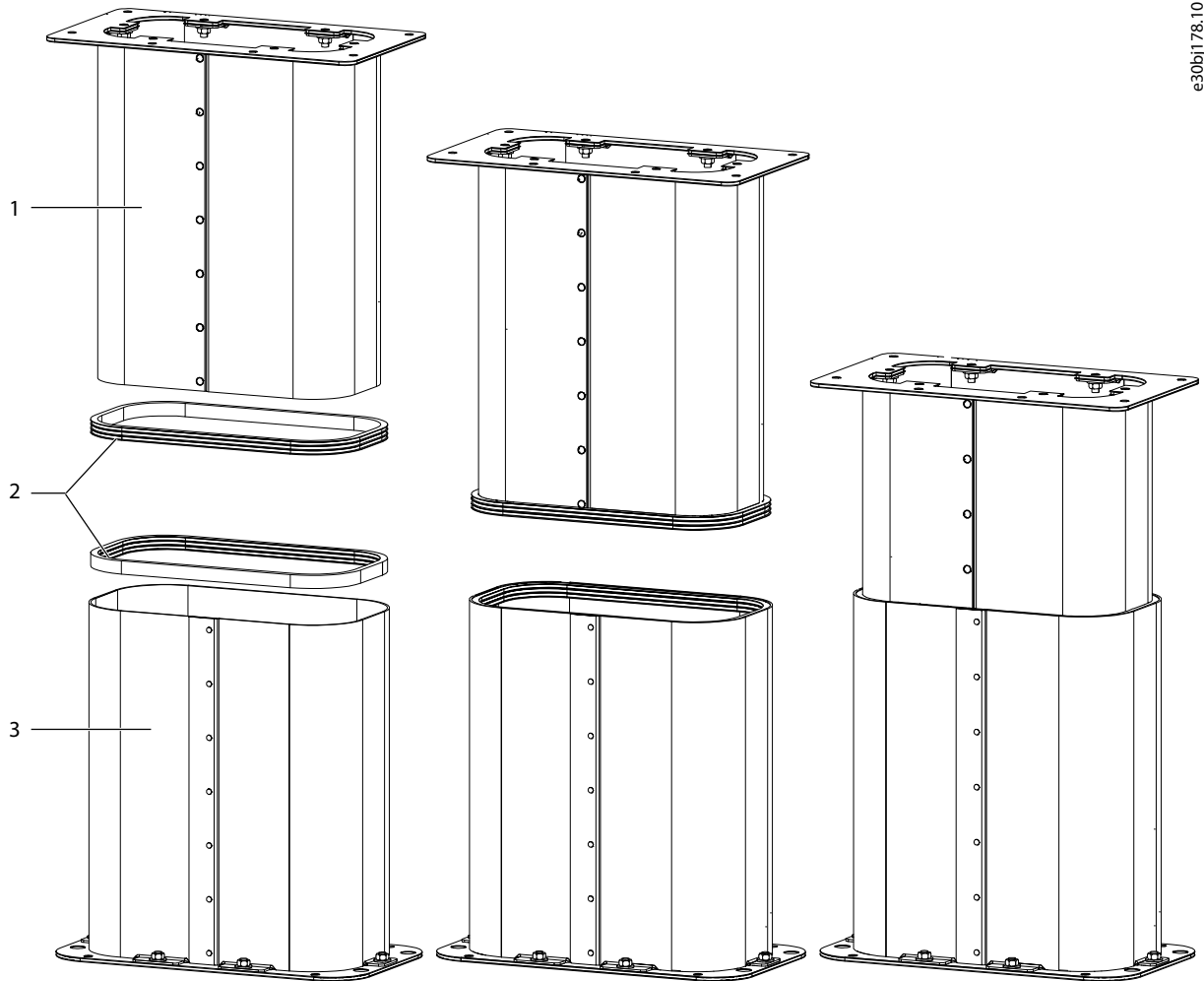

e30bj178.10

Illustration 9: Assembly of Telescopic Ducts

1	Inner sleeve of duct	3	Outer sleeve of duct
2	Ribbed EPDM rubber seal		

2.7 Installing the Top Duct Over the Top Vent

To attach the top duct over the top vent of the frequency converter, use the following steps. See [Illustration 10](#).

Procedure

- Remove 2 M5x14 screws (T25) at the back of the top vent, and retain the screws.
- Remove 3 M5x12 screws (T25) at the front of the top vent, and retain the screws.
- Position the top duct over the vent in the top of the frequency converter.
- Line up the holes in the lower flange with the screw holes in the frequency converter.
- Secure the lower flange to the frequency converter with 5 screws (T25) previously removed.

Torque fasteners to 2.3 Nm (20 in-lb).

6. Collapse the duct until installation of the cabinet top plate.

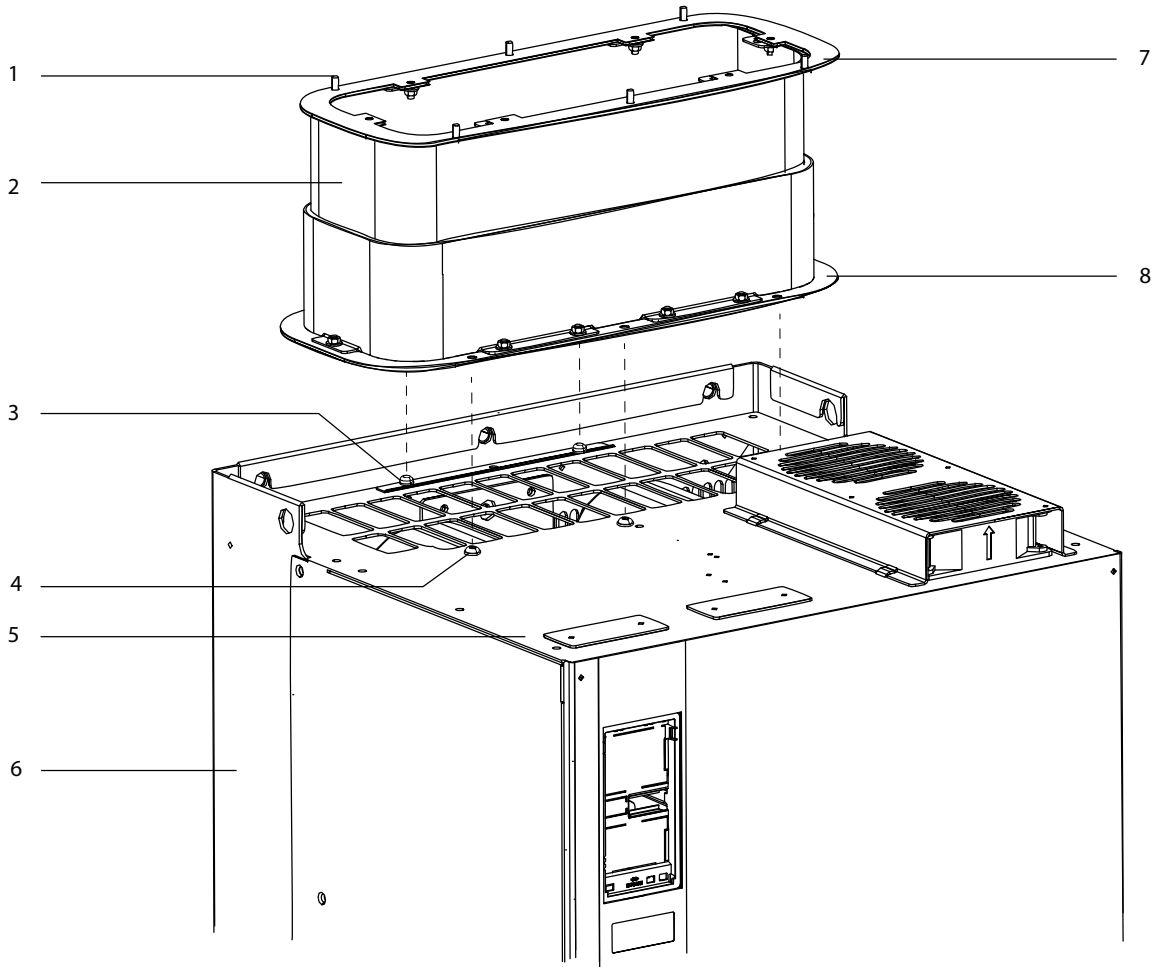

Illustration 10: Installation of the Top Duct Over the Top Vent

1	Threaded stud	5	Top of frequency converter
2	Top duct	6	Cooling back channel
3	M5x14 screw	7	Upper flange of duct
4	M5x12 screw	8	Lower flange of duct

2.8 Installing the Bottom Cover

NOTICE

DRAIN OPENING

The bottom cover features a drain opening in the middle of the plate.

- To drain moisture in wet or humid environments, attach nylon tubing with interior diameter of 8 mm (0.3 in).
- To seal the drain in dry environments, fasten a screw in the drain hole.

To install the bottom cover at the lower end of the cooling back channel, use the following steps. See [Illustration 11](#).

Procedure

1. Remove the paper backing from the bottom gasket.
2. Adhere the gasket to the upper side of the bottom cover.

3. Position the bottom cover and gasket over the opening at the lower end of the cooling channel.
4. Secure the bottom cover using the M5x14 screws (T25).

Torque screws to 2.3 Nm (20 in-lb). FA11 frequency converters require 8 screws, and FA12 frequency converters require 10 screws.

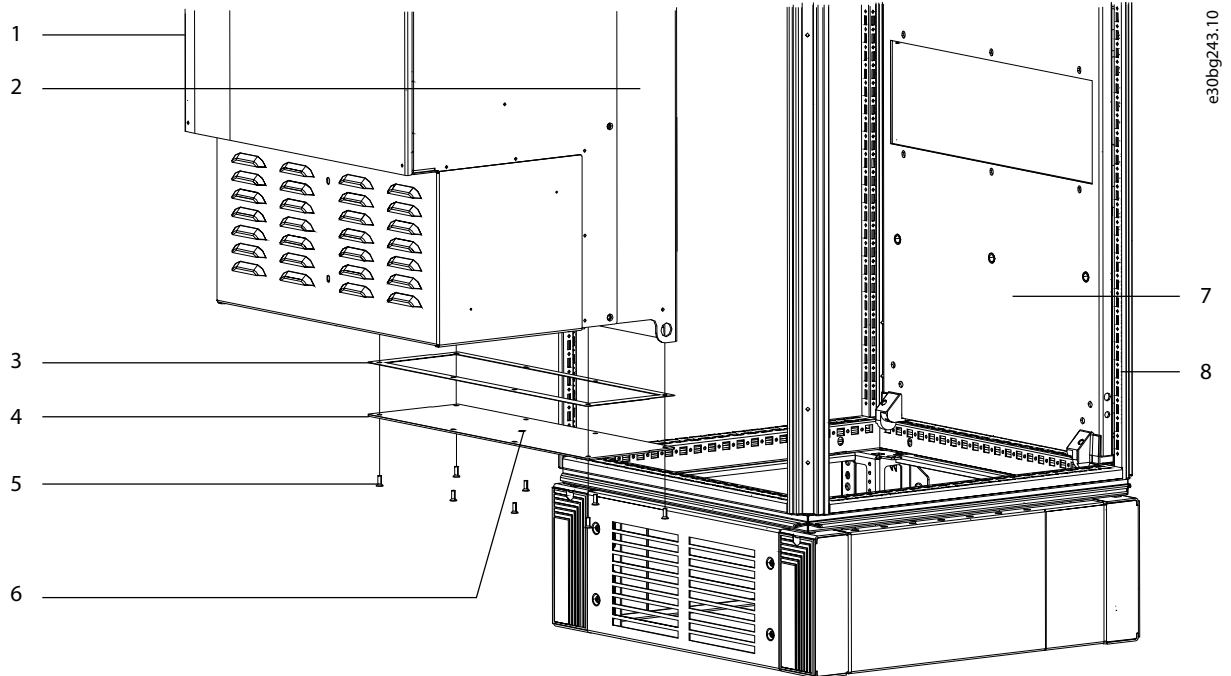

Illustration 11: Installation of the Bottom Cover

1	Frequency converter	5	M5x14 screws
2	Cooling back channel	6	Drain hole
3	Bottom gasket	7	Mounting plate
4	Bottom cover	8	Cabinet rails

2.9 Mounting the Frequency Converter

To install the mounting plate and frequency converter in the cabinet, use the following steps. Refer to [Illustration 12](#).

Procedure

1. Remove the paper backing from both 6-hole gaskets, exposing the adhesive.
2. Adhere 1 gasket around the vent opening on each side of the mounting plate.
3. Attach the mounting plate to the cabinet rails, making sure that the pem nuts face the back of the cabinet.
4. Fasten 3 M10 screws (not supplied) into the pem nuts at the lower end of the mounting plate.

Make sure that the screws are secure. The base of the frequency converter rests on these screws.

5. Slightly lean the top of the frequency converter forward and set the cutouts in the base onto the 3 screws.
6. Slowly push the top of the frequency converter back against the mounting plate until the top 3 pem nuts line up with the holes in the frequency converter.
7. Secure the top of the frequency converter using 3 M10 screws.

Torque the 6 M10 screws to 19 Nm (170 in-lb).

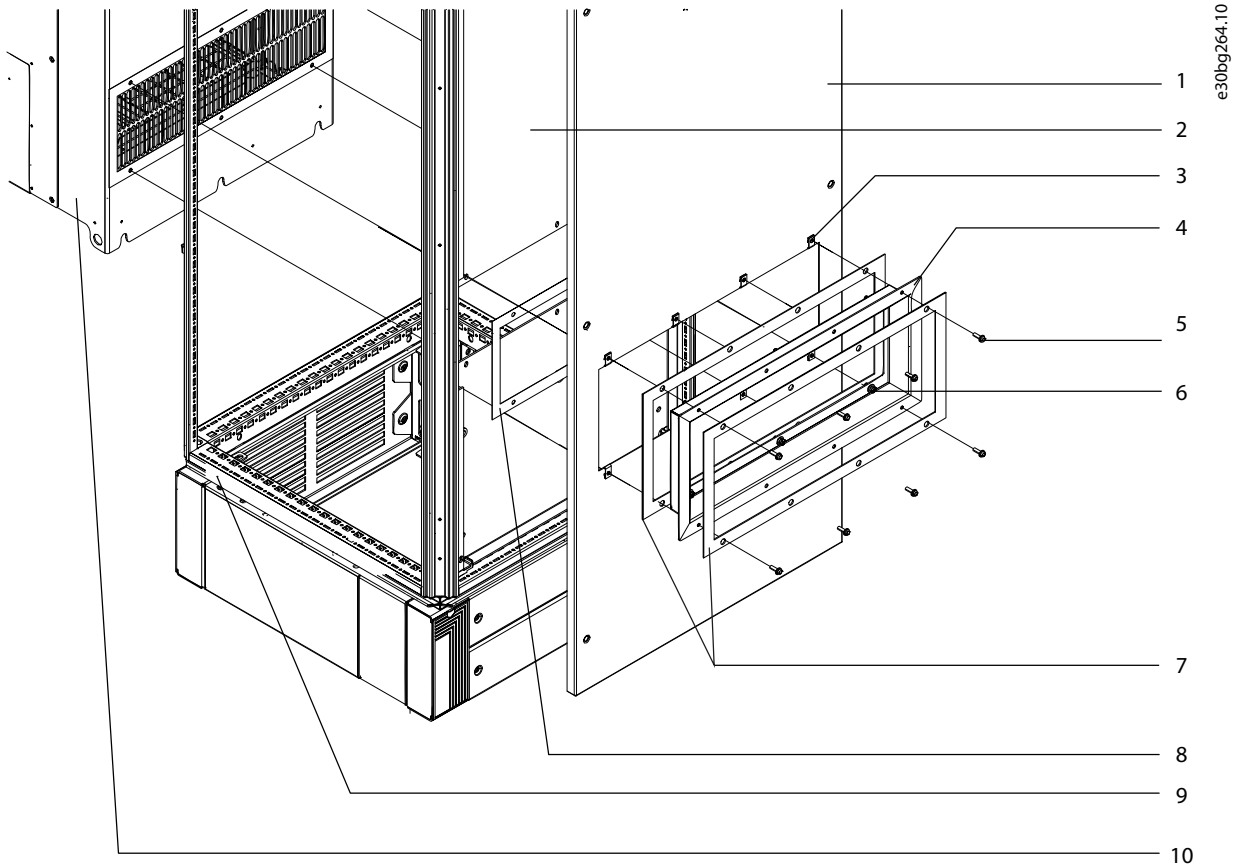

Illustration 12: Installation of the Frequency converter, Mounting Plate, Backplate, and Back Duct

1	Backplate	6	M6x12 screw
2	Mounting plate	7	8-hole gaskets
3	M5 clip-on nut	8	6-hole gaskets
4	Back duct	9	Rittal cabinet
5	M5x18 screw	10	Frequency converter

2.10 Attaching the Top Duct to the Top Plate

After the frequency converter is installed on the mounting plate, attach the top duct to the cabinet top plate using the following steps.

Procedure

1. Extend the telescopic top duct upward until the upper flange of the duct is positioned against the underside of the cabinet top plate.
2. Secure the duct to the top plate with 6 M5 hex nuts (T25).

Torque fasteners to 2.3 Nm (20 in-lb).

2.11 Installing the Backplate and Back Duct

To attach the cabinet backplate and the back duct, use the following steps.

Procedure

1. Position the backplate on the back rails of the cabinet behind the mounting plate.
2. Secure the backplate to the rails using the existing fasteners.
3. Slide 8 M5 clip-on nuts over the screw holes around the duct opening in the backplate.
4. Remove the paper backing from both 8-hole gaskets, exposing the adhesive.

5. Adhere 1 gasket to the back and 1 gasket to the front of the back duct outer flange.
6. Position the back duct in the hole created for it in the mounting plate and backplate.
7. Fasten the inner flange of the back duct with 6 M6x12 screws (T30).

Torque to 3.9 Nm (35 in-lb).

8. Fasten the outer flange of the duct with 8 M5x18 screws (T25).

Torque fasteners to 2.3 Nm (20 in-lb).

Danfoss A/S
Ulsnaes 1
DK-6300 Graasten
danfossdrives.com

Any information, including, but not limited to information on selection of product, its application or use, product design, weight, dimensions, capacity or any other technical data in product manuals, catalogues descriptions, advertisements, etc. and whether made available in writing, orally, electronically, online or via download, shall be considered informative, and is only binding if and to the extent, explicit reference is made in a quotation or order confirmation. Danfoss cannot accept any responsibility for possible errors in catalogues, brochures, videos and other material.

Danfoss reserves the right to alter its products without notice. This also applies to products ordered but not delivered provided that such alterations can be made without changes to form, fit or function of the product.

All trademarks in this material are property of Danfoss A/S or Danfoss group companies. Danfoss and the Danfoss logo are trademarks of Danfoss A/S. All rights reserved.

