



# KIT DC/DC CONVERTER ASSEMBLY

100379



**Installation and servicing of Danfoss Turbocor® compressors by qualified and product trained personnel only. Follow these instructions and sound refrigeration/electrical/servicing practices relating to installation, commissioning, maintenance and service.**

<p>Consult the appropriate Danfoss Turbocor Compressors Inc. (DTC) Service Manual on <a href="http://www.turbocoroem.com">www.turbocoroem.com</a> for detailed service instructions.</p>	<p><b>Never power compressor without covers in place and secured.</b></p> <p><b>Removing the mains input cover will expose you to a voltage hazard of up to 575V. Ensure the mains input power is off and locked out before removing cover.</b></p> <p><b>Before removing top cover, wait at least 20 minutes after isolating AC power to allow the high voltage capacitors to discharge.</b></p>	<p>Always wear appropriately rated safety equipment when working around equipment and/or components energized with high voltage.</p> <p><b>This equipment contains hazardous voltages that can cause serious injury or death.</b></p>	<p><b>Recover all refrigerant from compressor in accordance with local codes and ensure pressure is fully vented before the removal of refrigerant containing components.</b></p>
--	---	---	---

1 - Introduction:

DC-DC CONVERTER ASSEMBLY replacement.

This kit contains the DC-DC Converter and mounting hardware. Please refer to our Service Manual for details regarding the replacement of the DC-DC Converter.

We have made the **TTS/TGS/TTH/TGH Service Manual** available to anyone. To access the manual, you may scan the applicable QR code below or you may go to our DTC website at [www.turbocoroem.com](http://www.turbocoroem.com). At the top of the page there is a pull-down menu called "Quick Links." Click this menu and select the appropriate service manual.

Refer to the applicable QR code below to download the TTS/TGS/TTH/TGH Service Manual.

**English**



**Chinese**



There are two (2) variants of the DC-DC Converter. There is a potted style and an open-frame style DC-DC Converter. The removal and installation of the two (2) variants are very similar. The open-frame style utilizes six (6) mounting screws while the potted style uses eight (8). The open-frame style utilizes three (3) connectors whereas the potted style uses four (4). The open-frame design no longer uses the 15VAC trigger signal from the Soft Start, thus eliminating the need for J3.

The included DC-DC Converter is an open-frame style which is fully backwards compatible, and it handles all of the voltage applications. The potted DC-DC is specific to a given voltage, because of that, potted DC-DCs cannot be swapped to a compressor of a different voltage. To identify the two different styles, refer to Figure 1 (Open Frame DC-DC Converter) and Figure 2 (Potted DC-DC Converter).

Figure 1 – Open Frame DC-DC Converter

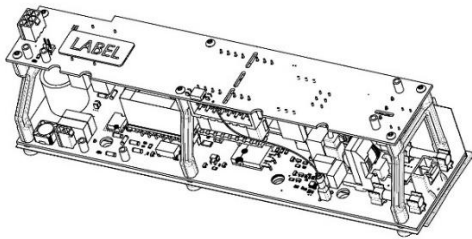
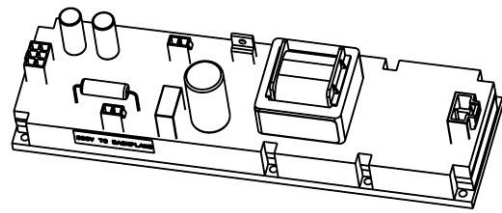

Figure 2 – Potted DC-DC Converter



## 2 - DC-DC CONVERTER ASSEMBLY Removal Instructions:

### General Removal

1. Isolate compressor power as described in the Electrical Isolation of the Compressor section of the Service Manual (M-SV-001).
2. Remove the Mains Input Cover.
3. Remove the Top Cover.
4. Remove the Service Side Cover.
5. Remove the Soft Start.
6. For Potted DC-DC Converters, continue to the **Potted DC-DC Converter Removal** section. For Open Frame DC-DC Converters, continue to the **Open Frame Removal** section.

### Potted DC-DC Converter Removal

1. Remove the four (4) connectors (DC Bus Input (J1), 250VDC (J2), 24VDC (J3), and 15VAC (J4)) from the DC-DC Converter. Refer to Figure 3 (Potted DC-DC Converter Connector Locations).

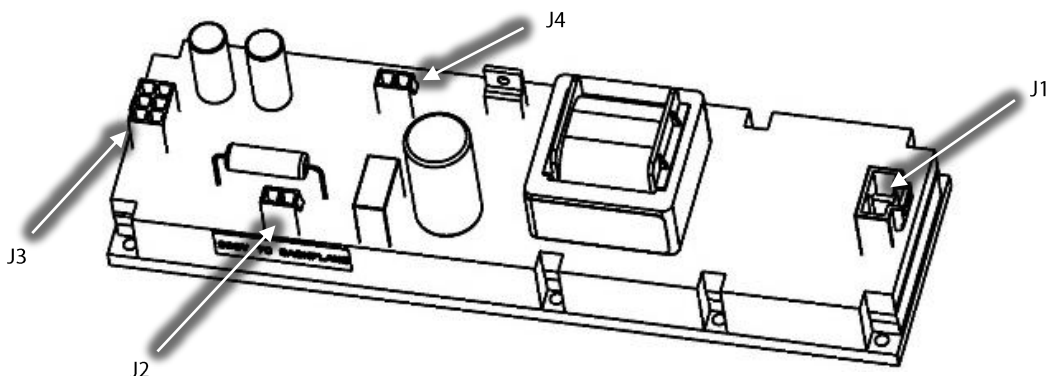

Figure 3 – Potted DC-DC Converter Connector Locations

2. Loosen the fasteners that are located next to the Inverter. Refer to Figure 4 (Potted DC-DC Converter Removal) for this and the next two (2) steps.
3. Remove the fasteners located on the front side of the DC-DC Converter.

4. Lift the DC-DC Converter on the front side and slide it clear of the rear fasteners.

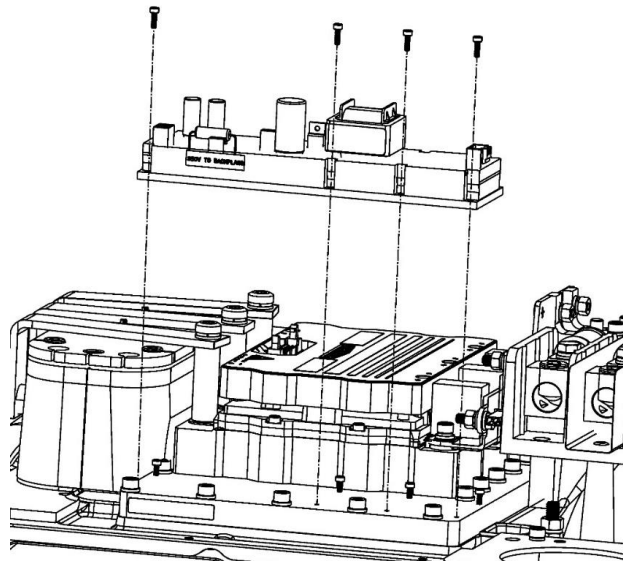

Figure 4 – Potted DC-DC Converter Removal

5. After the removal of the DC-DC Converter, completely remove the four (4) DC-DC Converter fasteners closest to the Inverter. Refer to Figure 5 (Rear Potted DC-DC Converter Fasteners).

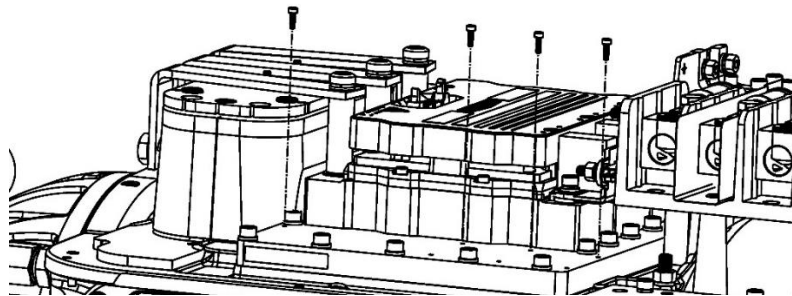

Figure 5 – Rear Potted DC-DC Converter Fasteners

6. Disconnect the J4, J20, J24, and J22 (if present) from the Backplane. Refer to Figure 6 (Backplane Connector Locations).

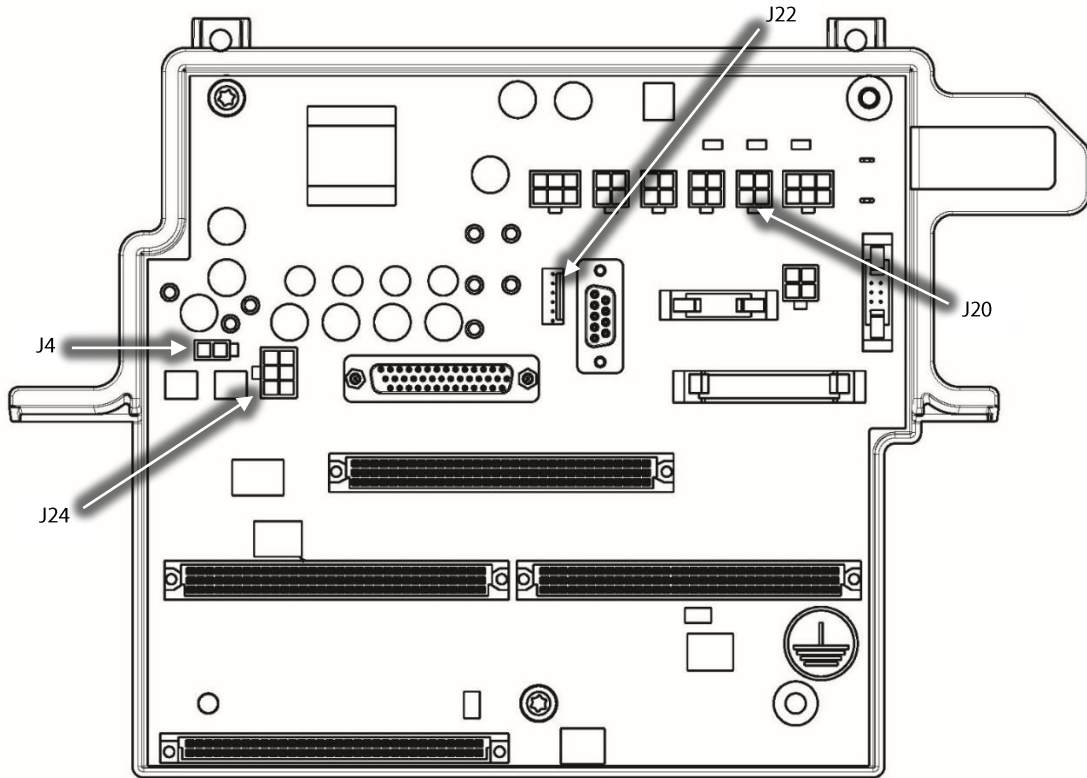

Figure 6 – Backplane Connector Locations

### Open Frame DC-DC Converter Removal

1. Remove the three (3) connectors (DC Bus Input (J1), 250VDC Output (J2), and 24VDC output (J4)) from the DC-DC Converter. Refer to Figure 7 (Open Frame DC-DC Converter Connector Locations).

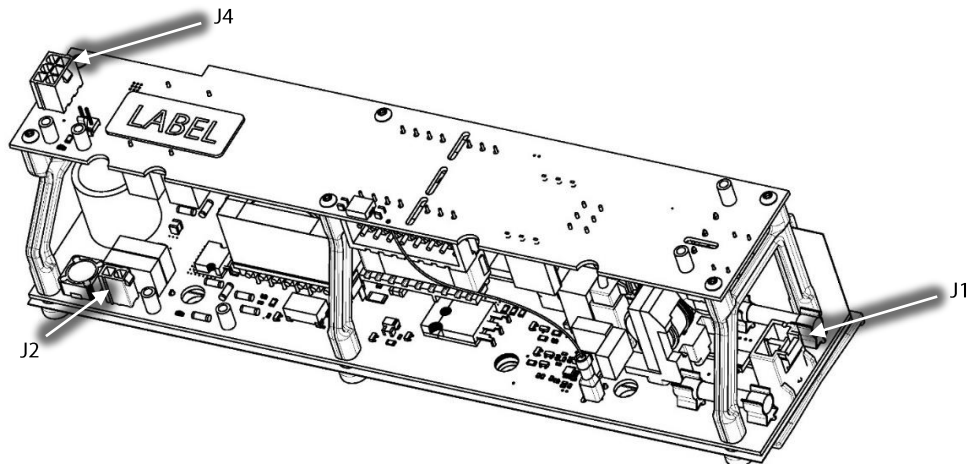

Figure 7 – Open Frame DC-DC Converter Connector Locations

2. Loosen the fasteners that are located next to the Inverter. Refer to Figure 8 (Open Frame DC-DC Converter Removal) for this and the next two (2) steps.
3. Remove the fasteners that are located on the front side of the DC-DC Converter.
4. Lift the DC-DC Converter on the front side and slide it clear of the rear fasteners.



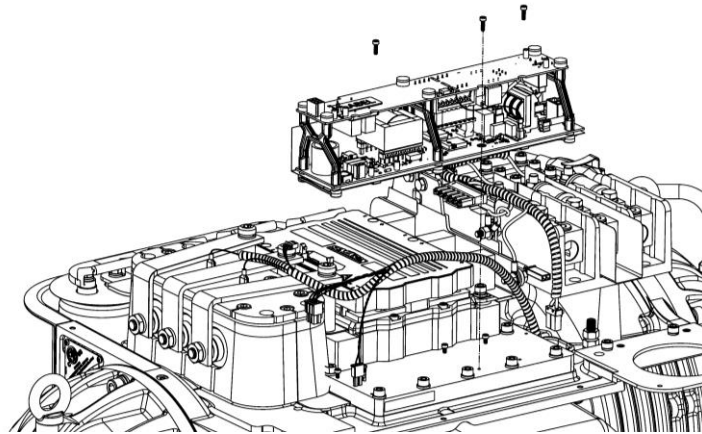

Figure 8 – Open Frame DC-DC Converter Removal

5. After the removal of the Open Frame DC-DC Converter, completely remove the three (3) DC-DC Converter fasteners closest to the Inverter. Refer to Figure 9 (Rear Open Frame DC-DC Converter Fasteners).

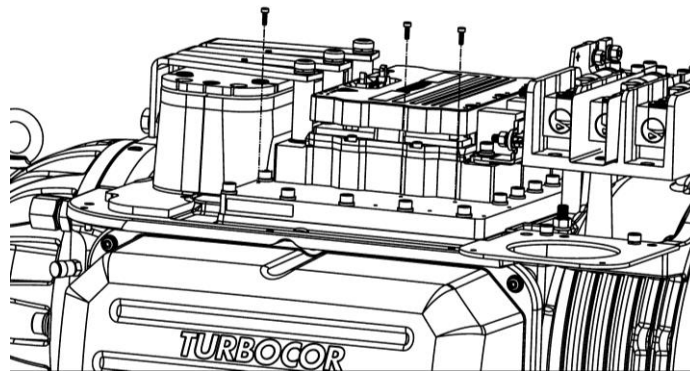

Figure 9 – Rear Open Frame DC-DC Fasteners

---

3 - DC-DC CONVERTER ASSEMBLY Installation Instruction:

---

**Converting from Potted DC-DC Converter Installation**

1. Clean the Inverter Heat Sink Plate where the original DC-DC Converter was mounted.
2. Install the new rear fasteners that secure the DC-DC Converter to the Inverter Heat Sink Plate. Do not tighten these fasteners; leave enough space under the fasteners to allow the DC-DC Converter to slide under the fasteners. Refer to Figure 10 (Rear Fastener Installation).

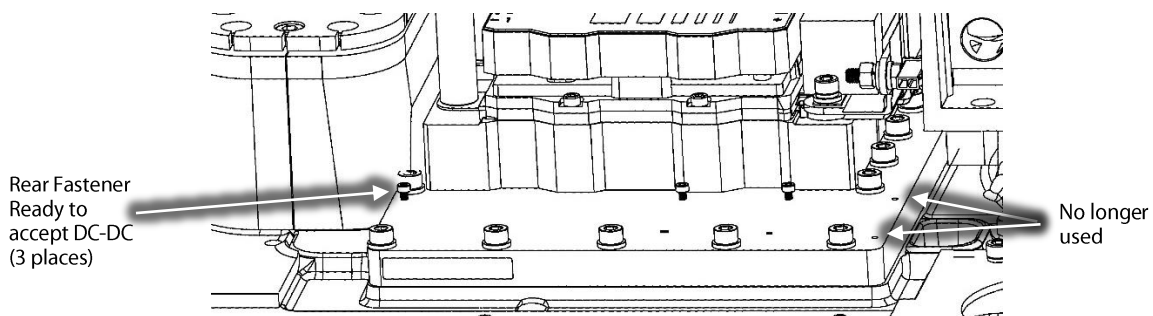

Figure 10 – Rear Fastener Installation

3. Align the DC-DC Converter with the mounting holes on the Inverter Heat Sink Plate by sliding the DC-DC under the rear fasteners.
4. Install the new front fasteners that secure the DC-DC Converter to the Inverter Heat Sink Plate. Torque all fasteners to 0.5 Nm (4 in.lb.). Refer to Figure 11 (DC-DC Converter Mounting Locations).

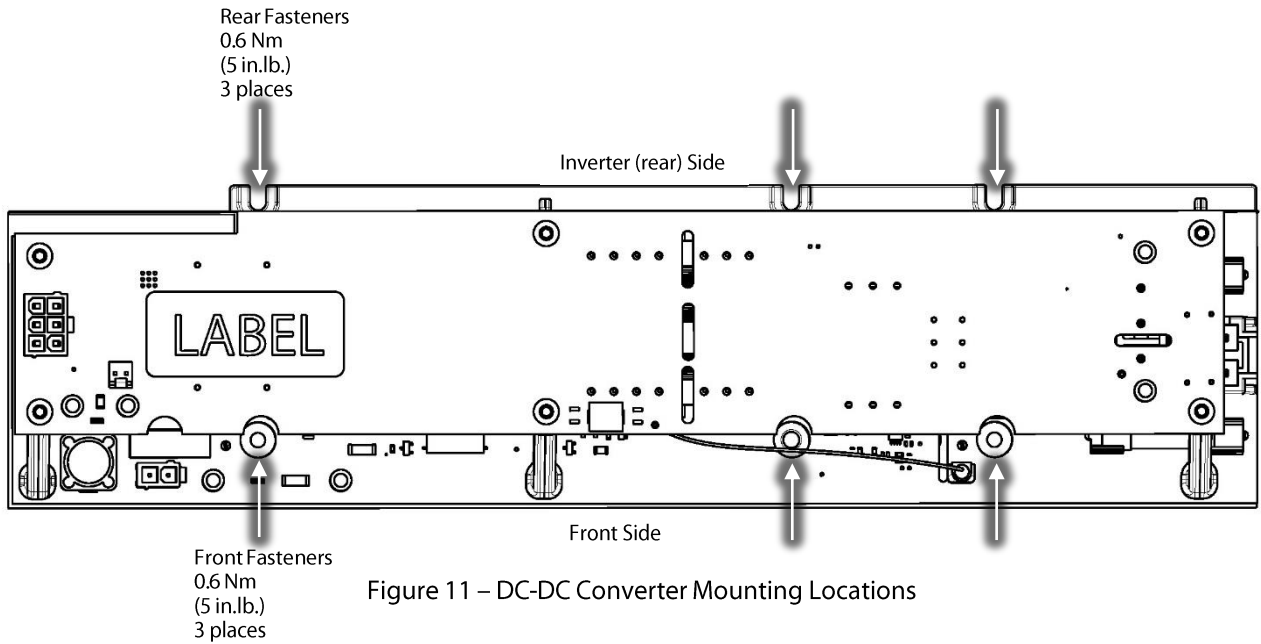

Figure 11 – DC-DC Converter Mounting Locations

5. Remove the cable ties as necessary and adjust the DC-DC to Backplane Cable Harness so that you can connect to J4 (24VDC output) and J2 (250VDC Output) to the DC-DC Converter. Refer to Figure 12 (DC-DC Converter Connector Locations) for this and the following step.
6. Connect the DC-DC to Soft Start Cable Harness to J1 (DC Bus Input).

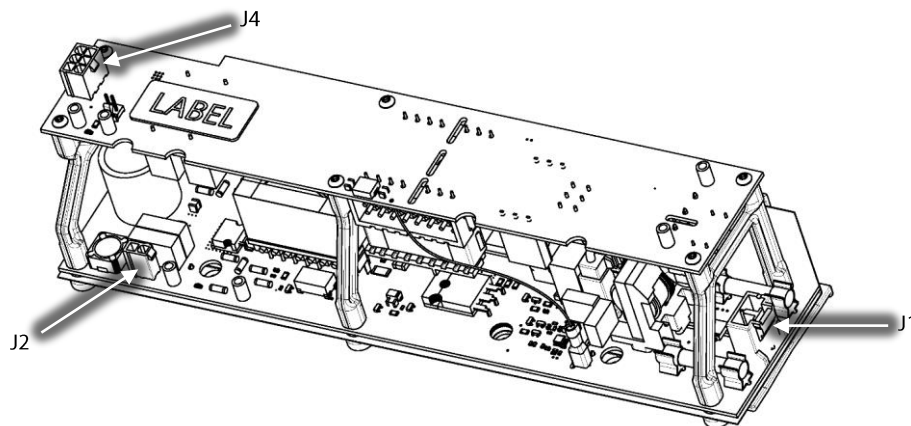

Figure 12 – DC-DC Converter Connector Locations

7. Adjust the DC-DC to Backplane Cable Harness so that you can install connectors J4, J20, J24, and J22 (if present) to the Backplane.
8. Once all connectors are installed, secure the DC-DC Converter Harness Cable to the IGBT to Backplane Harness with a cable tie as shown in Figure 13 (DC-DC Converter Harness Cable Tie).

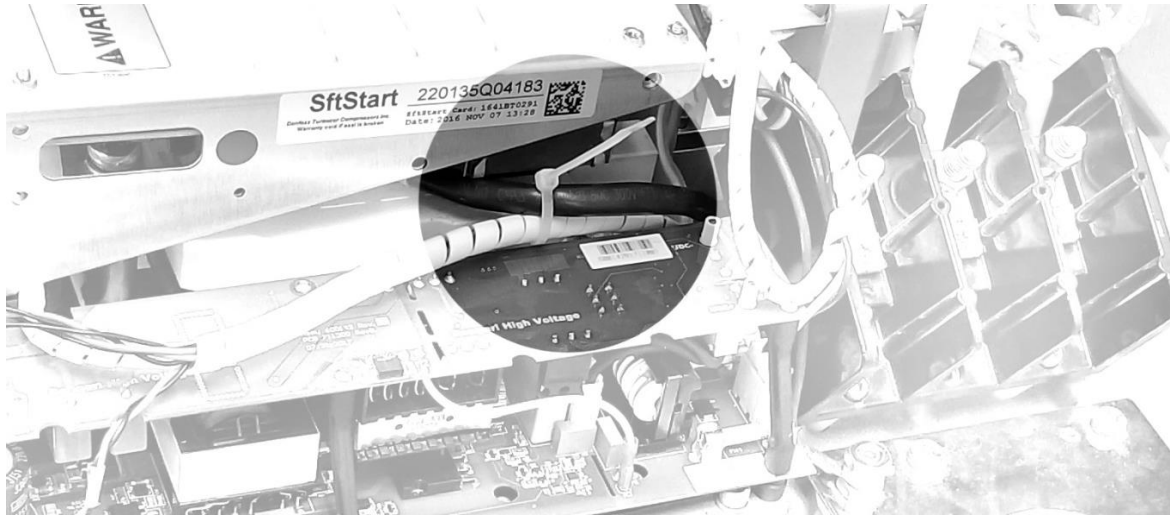

Figure 13 – DC-DC Converter Harness Cable Tie

9. The Open Frame DC-DC Converter no longer uses the 15VAC trigger signal from the Soft Start. Disconnect the cable from the Soft Start (J7). Refer to Figure 14 (Soft Start J7 Connector).

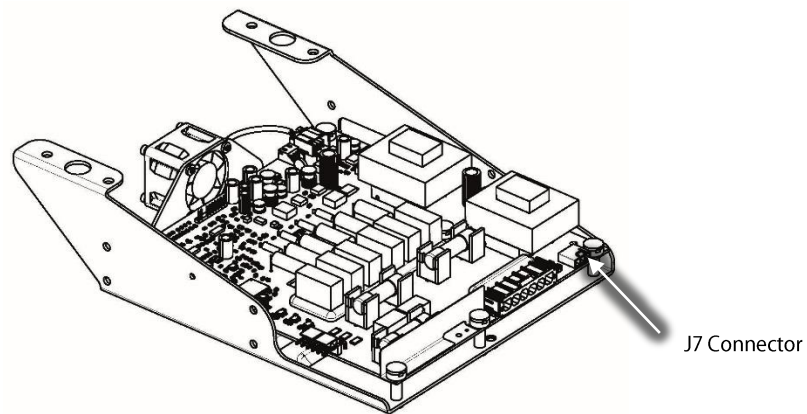

Figure 14 – Soft Start J7 Connector

10. Once all connectors are installed, install cable tie as shown in Figure 15 (Backplane Harness Cable Tie).



Figure 15 – Backplane Harness Cable Tie

11. Install a cable tie to secure both ends of the 15VAC trigger wire. Refer to Figure 16 (Trigger Signal Cable Tie).

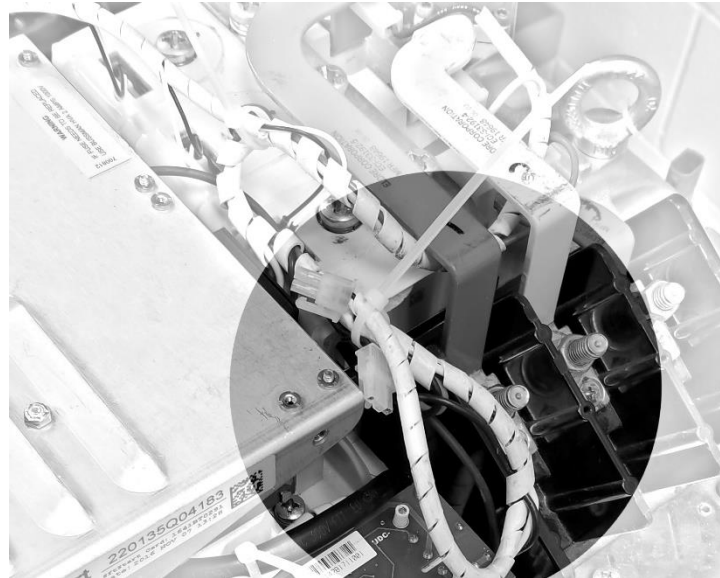

Figure 16 – Trigger Signal Cable Tie

12. Continue to **General Installation**.

**Open Frame to Open Frame DC-DC Converter Installation**

1. Install the new rear fasteners that secure the DC-DC Converter to the Inverter Heat Sink Plate. Do not tighten these fasteners; leave enough space under the fasteners to allow the DC-DC Converter to slide under the fasteners. Refer to Figure 17 (Rear Fastener Installation).

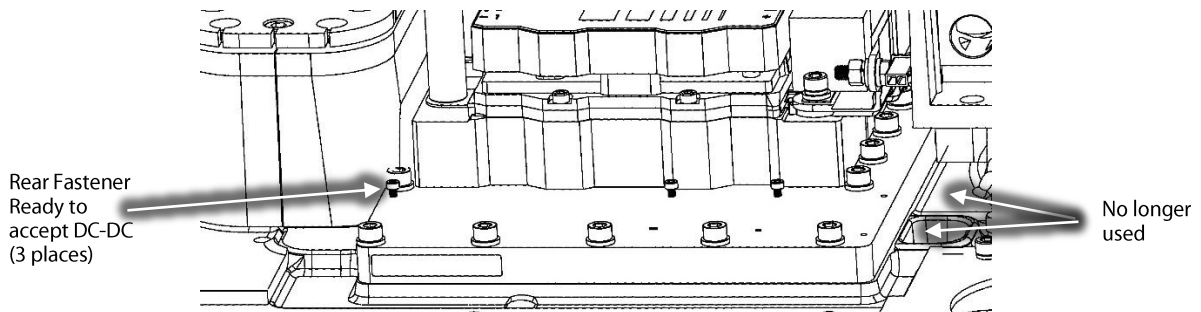

Figure 17 – Rear Fastener Installation

2. Align the DC-DC Converter with the mounting holes on the Inverter Heat Sink Plate by sliding the DC-DC under the rear fasteners.
3. Install the new front fasteners that secure the DC-DC Converter to the Inverter Heat Sink Plate. Torque all fasteners to 0.5 Nm (4 in.lb.). Refer to Figure 18 (DC-DC Converter Mounting Locations).



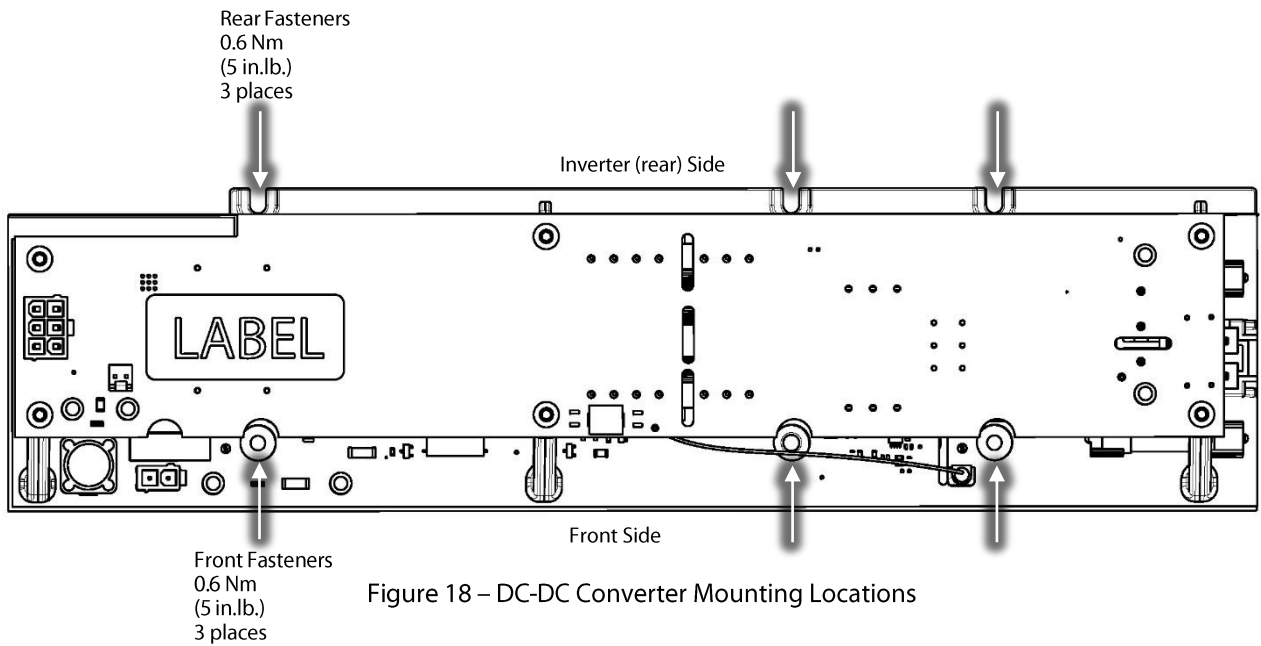

Figure 18 – DC-DC Converter Mounting Locations

4. Connect the DC-DC to Backplane Cable Harness to J1 (DC Bus Input), J4 (24VDC output), and J2 (250VDC Output) of the DC-DC Converter. Refer to Figure 19 (DC-DC Converter Connector Locations).

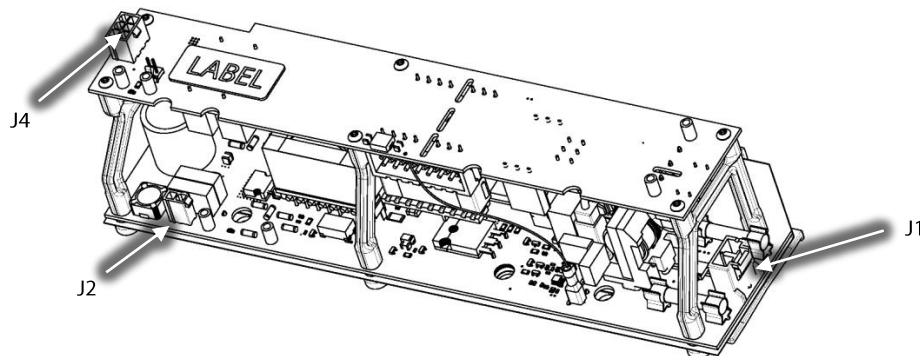

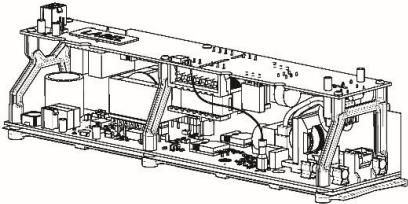

Figure 19 – DC-DC Converter Connector Locations

5. Continue to **General Installation**.

### General Installation

6. Install the Soft Start.
7. Install the Service Side Cover.
8. Install the Top Cover.
9. Install the Mains Input Cover.
10. Return the compressor to normal operation.

4 - Kit Contents:

QTY	Part(s) Description	Picture(s)
1	DC/DC CONVERTER	
6	SCREW M3 X 10, S/HD CAP	

Danfoss can accept no responsibility for possible errors in catalogues, brochures and other printed material. Danfoss reserves the right to alter its products without notice. This also applies to products already on order provided that such alterations can be made without subsequential changes being necessary in specifications already agreed. All trademarks in this material are property of the respective companies. Danfoss and the Danfoss logotype are trademarks of Danfoss A/S. All rights reserved.