

KIT Inlet Guide Vane (IGV) REPAIR KITS

100222, 100223, 100223-5, 100227, 100228, 100229, 100231, 100232, 100246, 100250, 100261, 100704, & 100705



Installation and servicing of Danfoss Turbocor® compressors by qualified and product trained personnel only. Follow these instructions and sound refrigeration/electrical/servicing practices relating to installation, commissioning, maintenance and service.

| | | | |
|--|---|---|---|
| <p>Consult the appropriate Danfoss Turbocor Compressors Inc. (DTC) Service Manual on turbocoroem.com for detailed service instructions.</p> | <p>Never power compressor without covers in place and secured.</p> <p>Removing the mains input cover will expose you to a voltage hazard of up to 575V. Ensure the mains input power is off and locked out before removing cover.</p> <p>Before removing top cover, wait at least 20 minutes after isolating AC power to allow the high voltage capacitors to discharge.</p> | <p>Always wear appropriately rated safety equipment when working around equipment and/or components energized with high voltage.</p> <p>This equipment contains hazardous voltages that can cause serious injury or death.</p> | <p>Recover all refrigerant from compressor in accordance with local codes and ensure pressure is fully vented before the removal of refrigerant containing components.</p> |
|--|---|---|---|

1 - Introduction:

IGV REPAIR KITS removal and installation instructions.

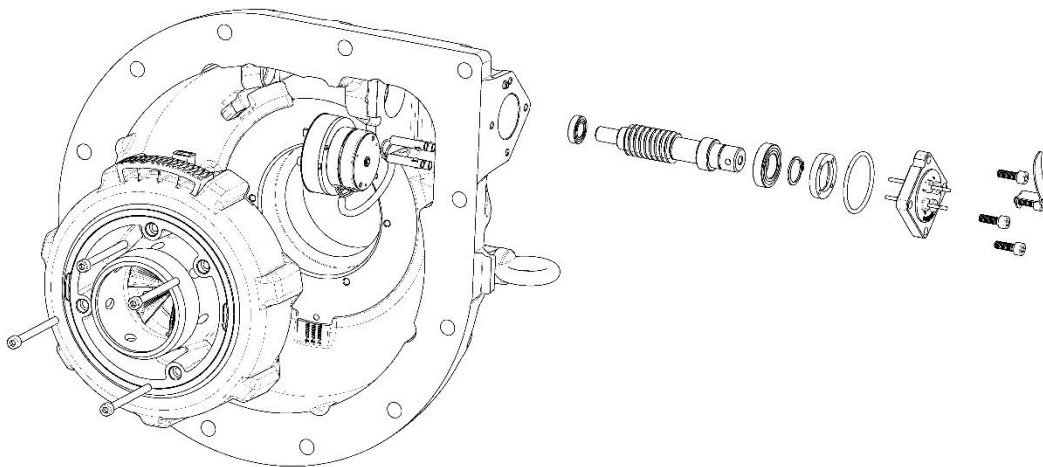

Please refer to our Service Manual for details regarding the replacement of the IGV Housing or any related component.

We have made the **TTS/TGS/TTH/TGH Service Manual** available to anyone. To access the manual, you may scan the applicable QR code below or you may go to our DTC website at www.turbocoroem.com. At the top of the page there is a pull-down menu called "Quick Links." Click this menu and select the appropriate service manual.

Refer to the applicable QR code below to download the TTS/TGS/TTH/TGH Service Manual.

English



Chinese



2 - IGV HOUSING Removal Instructions:









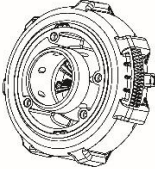

1. Isolate compressor power.
2. Isolate the compressor and recover the refrigerant according to industry standards.
3. Remove the IGV Housing Assembly.
4. Remove the IGV Feedthrough.
5. Remove the IGV Motor.
6. Remove the IGV Worm Gear.
7. Remove the IGV Throat.
8. Remove the small Worm Gear Bearing from the housing (if applicable).

3 - IGV HOUSING Installation Instructions:

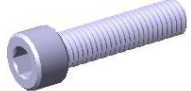
1. Install the small Worm Gear Bearing (if applicable).
2. Install the IGV Throat.
3. Install the IGV Worm Gear.
4. Install the IGV Motor.
5. Install the IGV Feedthrough.
6. Install the IGV Housing Assembly.
7. Leak test and evacuate compressor in accordance with standard industry practices.
8. Test run the compressor to verify proper operation and movement of the IGV assembly.
9. Return the compressor to normal operation.

4 - Kit Contents:





Note: Any part numbers included in the kit contents are internal part numbers only. Please refer to our Spare Parts Manuals for any kit part numbers.

| IGV Throat Repair Kits | | |
|------------------------|--------------------------------|---|
| Kit numbers | | |
| 100227 | | |
| QTY | Part(s) Description | Picture(s) |
| 1 | IGV Drive Assembly |  |
| 1 | SCREW, M5x8 SET SCREW – 900095 |  |
| 4 | SCREW, M5 – 901671 |  |
| 4 | SCREW, M5 – 902844 |  |
| 12 | SCREW, M10 – 902847 |  |
| 12 | WASHER, M10 FLAT – 902836 |  |
| 12 | WASHER, M10 SPLIT – 902839 |  |
| 1 | O-RING – ECONOMIZER – 901851 |  |
| 1 | O-RING – DISHCHARGE – 901853 |  |
| 1 | O-RING – SUCTION – 901854 |  |
| 1 | O-RING – IGV – 901855 |  |

| | | |
|---|-------------------------------|--|
| 1 | O-RING – IGV HOUSING – 901857 | |
| 2 | LUBRICATION-SUPER-O-LUBE-2G | |

| |
|--|
| IGV Throat Repair Kits |
| Kit numbers |
| 100228, 100231, 100232, 100250, 100261, 100704 |

| QTY | Part(s) Description | Picture(s) |
|-----|--------------------------------|------------|
| 1 | IGV Drive Assembly | |
| 1 | SCREW, M5x8 SET SCREW – 900095 | |
| 4 | SCREW, M5 – 901671 | |
| 4 | SCREW, M5 – 902844 | |
| 12 | SCREW, M10 – 902847 | |
| 12 | WASHER, M10 FLAT – 902836 | |
| 12 | WASHER, M10 SPLIT – 902839 | |
| 1 | O-RING – ECONOMIZER – 901852 | |
| 1 | O-RING – DISHCHARGE – 901853 | |

| | | |
|---|-------------------------------|---|
| 1 | O-RING – SUCTION – 901854 |  |
| 1 | O-RING – IGV – 901855 |  |
| 1 | O-RING – IGV HOUSING – 901857 |  |
| 2 | LUBRICATION-SUPER-O-LUBE-2G |  |

| | |
|----------------------------------|--|
| IGV Worm Gear & Motor Repair Kit | |
| Kit numbers | |
| 100222, 100705 | |

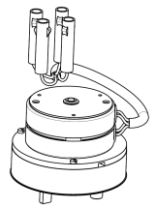
| QTY | Part(s) Description | Picture(s) |
|-----|--|---|
| 1 | WORM IGV | |
| 1 | COLLAR - IGV WORM BEARING | |
| 1 | MOTOR - IGV 12VDC STEPPER |  |
| 1 | CIRCLIP - Ø17 RETAINING RING EXTERNAL | |
| 1 | BEARING, BALL - RADIAL Ø10 ID x Ø19 OD - NO LUBE | |
| 1 | BEARING, BALL - RADIAL Ø17 ID x Ø30 OD - NO LUBE | |
| 1 | SCREW M5X 8 S/SET FLT POINT | |

| | |
|-----------------------------|--|
| IGV Extractor Worm Gear Kit | |
| Kit numbers | |
| 100246 | |

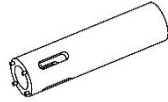
| QTY | Part(s) Description | Picture(s) |
|-----|-----------------------|---|
| 1 | EXTRACTOR - WORM GEAR |  |

Danfoss can accept no responsibility for possible errors in catalogues, brochures and other printed material. Danfoss reserves the right to alter its products without notice. This also applies to products already on order provided that such alterations can be made without subsequential changes being necessary in specifications already agreed. All trademarks in this material are property of the respective companies. Danfoss and the Danfoss logotype are trademarks of Danfoss A/S. All rights reserved.