

KIT IGV REPAIR KITS – VTX

110121, 112039, 112040, 112041, 112042, 112043, 112044, 112045, 112046, & 112057.



Installation and servicing of Danfoss Turbocor® compressors by qualified and product trained personnel only. Follow these instructions and sound refrigeration/electrical/servicing practices relating to installation, commissioning, maintenance and service.

<p>Consult the appropriate Danfoss Turbocor Compressors Inc. (DTC) Service Manual on turbocoroem.com for detailed service instructions.</p>	<p>Never power compressor without covers in place and secured.</p> <p>Opening the drive panel will expose you to a voltage hazard of up to 575V AC and 900V DC. Ensure the mains input power is off and locked out before opening panel.</p> <p>Before opening the drive panel, wait at least 20 minutes after isolating AC power to allow the high voltage capacitors to discharge.</p>	<p>Always wear appropriately rated safety equipment when working around equipment and/or components energized with high voltage.</p> <p>This equipment contains hazardous voltages that can cause serious injury or death.</p>	<p>Recover all refrigerant from compressor in accordance with local codes and ensure pressure is fully vented before the removal of refrigerant containing components.</p>
--	---	---	---

1 - Introduction

This instruction covers many different IGV kits. The contents for each kit are listed at the end of this document. The included steps provide an overview of what is required to remove and install the IGV assembly. Please refer to our Service Manual for details regarding the replacement of the specific component(s) in your spare parts kit.

We have made the **VTT/VTX Service Manual** available to anyone. To access the manual, you may scan the applicable QR code below or you may go to our DTC website at www.turbocoroem.com. At the top of the page there is a pull-down menu called "Quick Links." Click this menu and select the appropriate service manual.

Refer to the applicable QR code below to download the VTT/VTX Service Manual.

English



Chinese



Danfoss can accept no responsibility for possible errors in catalogues, brochures and other printed material. Danfoss reserves the right to alter its products without notice. This also applies to products already on order provided that such alterations can be made without subsequential changes being necessary in specifications already agreed. All trademarks in this material are property of the respective companies. Danfoss and the Danfoss logotype are trademarks of Danfoss A/S. All rights reserved.

2 - IGV MOTOR SERVICE Removal Instructions



1. Isolate VTT/VTX power as described in Section "Electrical Isolation of the VFD" of the Service Manual (M-SV-VT-001).
2. Isolate the compressor and recover the refrigerant according to industry standards.
3. Remove the IGV Harness from the IGV Feedthrough.
4. Remove the IGV Housing Assembly.
5. Remove the IGV Feedthrough.
6. Remove the IGV Motor.
7. Remove the IGV Worm Gear.
8. Remove the IGV Throat.

3 - IGV MOTOR SERVICE Installation Instructions

1. Install the IGV Throat.
2. Install the IGV Worm Gear.
1. Install the IGV Motor.
2. Install the IGV Feedthrough.
3. Install the IGV Housing Assembly.
4. Leak test and evacuate compressor in accordance with standard industry practices.
5. Test run the compressor to verify proper operation and movement of the IGV assembly.
6. Return the compressor to normal operation.

4 - Kit Contents

Note: Any part numbers included in the kit contents are internal part numbers only. Please refer to our Spare Parts Manuals for any kit part numbers.

Kit numbers	Kit description	Compressor models
112039	VTX IGV Suction Housing O-ring	VTX
QTY	Part(s) Description	Picture(s)
16	SCREW, M12 – 902521	
16	WASHER, M12 FLAT – 902122	
16	WASHER, M12 SPLIT – 902123	
1	O-RING – IGV Suction Housing – 902959	







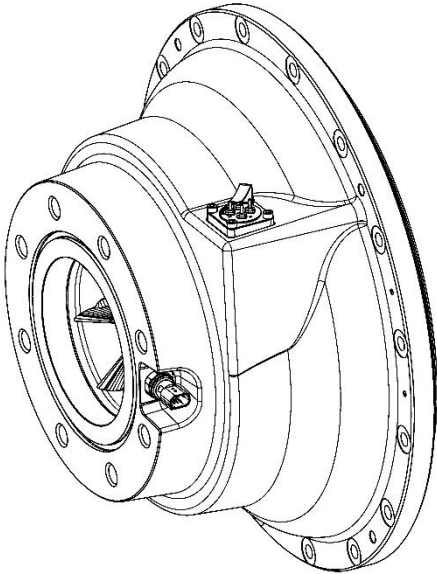



Danfoss can accept no responsibility for possible errors in catalogues, brochures and other printed material. Danfoss reserves the right to alter its products without notice. This also applies to products already on order provided that such alterations can be made without consequential changes being necessary in specifications already agreed. All trademarks in this material are property of the respective companies. Danfoss and the Danfoss logotype are trademarks of Danfoss A/S. All rights reserved.

1	O-RING – Suction – 902954	
1	O-RING – Discharge – 920354	
1	O-RING – Economizer – 920331	
1	O-RING – Inlet Cooling Flange – 920212	
1	O-RING – Exit Cooling Flange – 920222	
3	LUBRICATION-SUPER-O-LUBE-2G	







Kit numbers	Kit description	Compressor models
112040	VTX IGV Drive Assembly and O-ring	VTX

QTY	Part(s) Description	Picture(s)
1	IGV SUCTION ASSEMBLY – VTX	

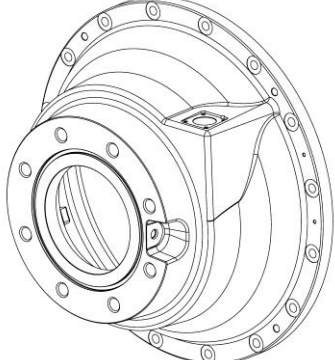



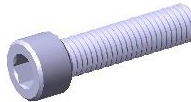
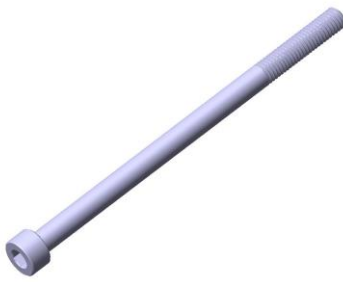



Danfoss can accept no responsibility for possible errors in catalogues, brochures and other printed material. Danfoss reserves the right to alter its products without notice. This also applies to products already on order provided that such alterations can be made without subsequential changes being necessary in specifications already agreed. All trademarks in this material are property of the respective companies. Danfoss and the Danfoss logotype are trademarks of Danfoss A/S. All rights reserved.

16	SCREW, M12 – 902521	
16	WASHER, M12 FLAT – 902122	
16	WASHER, M12 SPLIT – 902123	
1	O-RING – IGV Suction Housing – 902959	
1	O-RING – Suction – 902954	
1	O-RING – Discharge – 920354	
1	O-RING – Economizer – 920331	
1	O-RING – Inlet Cooling Flange – 920212	
1	O-RING – Exit Cooling Flange – 920222	
3	LUBRICATION-SUPER-O-LUBE-2G	

Danfoss can accept no responsibility for possible errors in catalogues, brochures and other printed material. Danfoss reserves the right to alter its products without notice. This also applies to products already on order provided that such alterations can be made without subsequential changes being necessary in specifications already agreed. All trademarks in this material are property of the respective companies. Danfoss and the Danfoss logotype are trademarks of Danfoss A/S. All rights reserved.







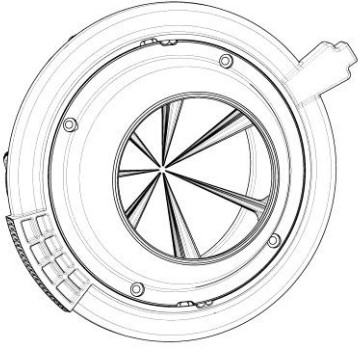

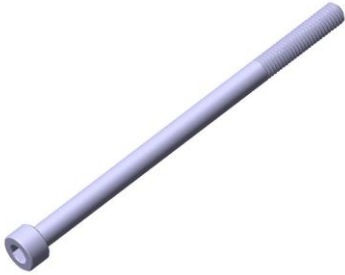

Kit numbers	Kit description	Compressor models
112041	VTX IGV Housing	VTX
QTY	Part(s) Description	Picture(s)
1	IGV, SUCTION HOUSING	
16	SCREW, M12 – 902521	
16	WASHER, M12 FLAT – 902122	
16	WASHER, M12 SPLIT – 902123	
4	SCREW, M5 – 902844	
4	SCREW, M5 – 902973	
4	WASHER, M5 SPLIT – 902808	

Danfoss can accept no responsibility for possible errors in catalogues, brochures and other printed material. Danfoss reserves the right to alter its products without notice. This also applies to products already on order provided that such alterations can be made without subsequential changes being necessary in specifications already agreed. All trademarks in this material are property of the respective companies. Danfoss and the Danfoss logotype are trademarks of Danfoss A/S. All rights reserved.



1	O-RING – IGV Feedthrough – 901855	
1	O-RING – IGV Suction Housing – 902959	
1	O-RING – Suction – 902954	
1	O-RING – Discharge – 920354	
1	O-RING – Economizer – 920331	
1	O-RING – Inlet Cooling Flange – 920212	
1	O-RING – Exit Cooling Flange – 920222	
3	LUBRICATION-SUPER-O-LUBE-2G	

Kit numbers	Kit description	Compressor models
112042	VTX IGV Throat	VTX
QTY	Part(s) Description	Picture(s)
1	IGV DRIVE	

Danfoss can accept no responsibility for possible errors in catalogues, brochures and other printed material. Danfoss reserves the right to alter its products without notice. This also applies to products already on order provided that such alterations can be made without subsequential changes being necessary in specifications already agreed. All trademarks in this material are property of the respective companies. Danfoss and the Danfoss logotype are trademarks of Danfoss A/S. All rights reserved.













16	SCREW, M12 – 902521	
16	WASHER, M12 FLAT – 902122	
16	WASHER, M12 SPLIT – 902123	
4	SCREW, M5 – 902973	
4	WASHER, M5 SPLIT – 902808	
1	O-RING – IGV Feedthrough – 901855	
1	O-RING – IGV Suction Housing – 902959	
1	O-RING – Suction – 902954	
1	O-RING – Discharge – 920354	
1	O-RING – Economizer – 920331	
1	O-RING – Inlet Cooling Flange – 920212	

Danfoss can accept no responsibility for possible errors in catalogues, brochures and other printed material. Danfoss reserves the right to alter its products without notice. This also applies to products already on order provided that such alterations can be made without subsequential changes being necessary in specifications already agreed. All trademarks in this material are property of the respective companies. Danfoss and the Danfoss logotype are trademarks of Danfoss A/S. All rights reserved.









1	O-RING – Exit Cooling Flange – 920222	
3	LUBRICATION-SUPER-O-LUBE-2G	

Kit numbers	Kit description	Compressor models
112044	VTX - IGV Worm Gear Shaft Repair	VTX
QTY	Part(s) Description	Picture(s)
1	MOTOR ASSEMBLY - IGV 12VDC STEPPER	
1	SCREW, M5 – S/SET FLT POINT – 900095	
16	SCREW, M12 – 902521	
4	SCREW, M5 – 902844	
16	WASHER, M12 FLAT – 902122	
16	WASHER, M12 SPLIT – 902123	



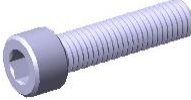

Danfoss can accept no responsibility for possible errors in catalogues, brochures and other printed material. Danfoss reserves the right to alter its products without notice. This also applies to products already on order provided that such alterations can be made without subsequential changes being necessary in specifications already agreed. All trademarks in this material are property of the respective companies. Danfoss and the Danfoss logotype are trademarks of Danfoss A/S. All rights reserved.

1	WORM GEAR, IGV	
1	BEARING, BALL - RADIAL Ø17 ID x Ø30 OD	
1	BEARING, BALL - RADIAL Ø10 ID x Ø19 OD	
1	CIRCLIP, Ø17 RETAINING RING EXTERNAL	
1	COLLAR, IGV WORM BEARING	
1	O-RING – IGV Feedthrough – 901855	
1	O-RING – IGV Suction Housing – 902959	
1	O-RING – Suction – 902954	
1	O-RING – Discharge – 920354	
1	O-RING – Economizer – 920331	
1	O-RING – Inlet Cooling Flange – 920212	
1	O-RING – Exit Cooling Flange – 920222	
3	LUBRICATION-SUPER-O-LUBE-2G	



Danfoss can accept no responsibility for possible errors in catalogues, brochures and other printed material. Danfoss reserves the right to alter its products without notice. This also applies to products already on order provided that such alterations can be made without subsequent changes being necessary in specifications already agreed. All trademarks in this material are property of the respective companies. Danfoss and the Danfoss logotype are trademarks of Danfoss A/S. All rights reserved.

Kit numbers	Kit description	Compressor models
112045	IGV Motor Service - VTX	VTX
QTY	Part(s) Description	Picture(s)
1	MOTOR ASSEMBLY - IGV 12VDC STEPPER	
1	SCREW, M5 – S/SET FLT POINT – 900095	
16	SCREW, M12 – 902521	
16	WASHER, M12 FLAT – 902122	
16	WASHER, M12 SPLIT – 902123	
4	SCREW, M5 – 902844	
1	O-RING – IGV Feedthrough – 901855	
1	O-RING – IGV Suction Housing – 902959	
1	O-RING – Suction – 902954	
1	O-RING – Discharge – 920354	

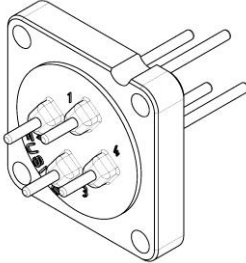
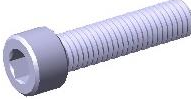
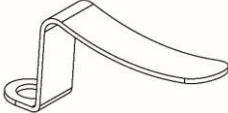

Danfoss can accept no responsibility for possible errors in catalogues, brochures and other printed material. Danfoss reserves the right to alter its products without notice. This also applies to products already on order provided that such alterations can be made without subsequential changes being necessary in specifications already agreed. All trademarks in this material are property of the respective companies. Danfoss and the Danfoss logotype are trademarks of Danfoss A/S. All rights reserved.

1	O-RING – Economizer – 920331	
1	O-RING – Inlet Cooling Flange – 920212	
1	O-RING – Exit Cooling Flange – 920222	
3	LUBRICATION-SUPER-O-LUBE-2G	

Kit numbers	Kit description	Compressor models
110121	IGV – Hermetic Feedthrough IGV 4 Pin	VTX

QTY	Part(s) Description	Picture(s)
1	HERMETIC FEEDTHROUGH - 4 PIN	
4	SCREW, M5 – 902844	
1	CLAMP	
1	O-RING – IGV Feedthrough – 901855	
1	LUBRICATION-SUPER-O-LUBE-2G	

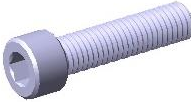
Danfoss can accept no responsibility for possible errors in catalogues, brochures and other printed material. Danfoss reserves the right to alter its products without notice. This also applies to products already on order provided that such alterations can be made without subsequential changes being necessary in specifications already agreed. All trademarks in this material are property of the respective companies. Danfoss and the Danfoss logotype are trademarks of Danfoss A/S. All rights reserved.

Kit numbers	Kit description	Compressor models
112046	O-ring IGV – Hermetic Feedthrough IGV 4 Pin	VTX
QTY	Part(s) Description	Picture(s)
4	SCREW, M5 – 902844	
1	O-RING – IGV Feedthrough – 901855	
1	LUBRICATION-SUPER-O-LUBE-2G	

Kit numbers	Kit description	Compressor models
112043	MAGNET – IGV 1/4"x3/8"	VTX
QTY	Part(s) Description	Picture(s)
3	MAGNET, IGV	

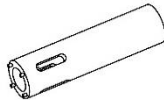
Kit numbers	Kit description	Compressor models
112057	EXTRACTOR - WORM GEAR	VTX
QTY	Part(s) Description	Picture(s)
1	EXTRACTOR, WORM GEAR	

Danfoss can accept no responsibility for possible errors in catalogues, brochures and other printed material. Danfoss reserves the right to alter its products without notice. This also applies to products already on order provided that such alterations can be made without subsequent changes being necessary in specifications already agreed. All trademarks in this material are property of the respective companies. Danfoss and the Danfoss logotype are trademarks of Danfoss A/S. All rights reserved.