



KIT 'O-RINGS – SUCTION, DISCHARGE, ECONOMIZER, MOTOR COOLING PORTS

100155, 100327, 100329, 100555

 <p>Installation and servicing of Danfoss Turbocor® compressors by qualified and product trained personnel only. Follow these instructions and sound refrigeration/electrical/servicing practices relating to installation, commissioning, maintenance and service.</p>			
<p>Consult the appropriate Danfoss Turbocor Compressors Inc. (DTC) Service Manual on www.turbocoroem.com for detailed service instructions.</p>	<p>Never power compressor without covers in place and secured.</p> <p>Removing the mains input cover will expose you to a voltage hazard of up to 575V. Ensure the mains input power is off and locked out before removing cover.</p> <p>Before removing top cover, wait at least 20 minutes after isolating AC power to allow the high voltage capacitors to discharge.</p>	<p>Always wear appropriately rated safety equipment when working around equipment and/or components energized with high voltage.</p> <p>This equipment contains hazardous voltages that can cause serious injury or death.</p>	<p>Recover all refrigerant from compressor in accordance with local codes and ensure pressure is fully vented before the removal of refrigerant containing components.</p>

1 - Introduction

O-RINGS – SUCTION, DISCHARGE, ECONOMIZER, MOTOR COOLING PORTS Removal and installation.

This kit contains the O-rings for the suction, discharge, economizer, and motor cooling ports. Please refer to our Service Manual for details regarding the replacement of the O-rings.

We have made the **TTS/TGS/TTH/TGH Service Manual** available to anyone. To access the manual, you may scan the applicable QR code below or you may go to our DTC website at www.turbocoroem.com. At the top of the page there is a pull-down menu called "Quick Links." Click this menu and select the appropriate service manual.

Refer to the applicable QR code below to download the TTS/TGS/TTH/TGH Service Manual.

English



Chinese



2 - O-RINGS – SUCTION, DISCHARGE, ECONOMIZER, MOTOR COOLING PORTS Removal Instructions:

1. Isolate compressor power.
2. Isolate the compressor and recover the refrigerant according to industry standards.
3. Remove and discard the old O-rings.

3 - O-RINGS – SUCTION, DISCHARGE, ECONOMIZER, MOTOR COOLING PORTS Installation Instructions:

1. Ensure the O-ring location is clean and free from all contamination.
2. Remove each O-ring to be installed from its package and inspect for damage or defects.
3. Lubricate each O-ring.
4. Place appropriate O-ring in its specific location.
5. Leak test and evacuate compressor in accordance with standard industry practices.
6. Return the compressor to normal operation.

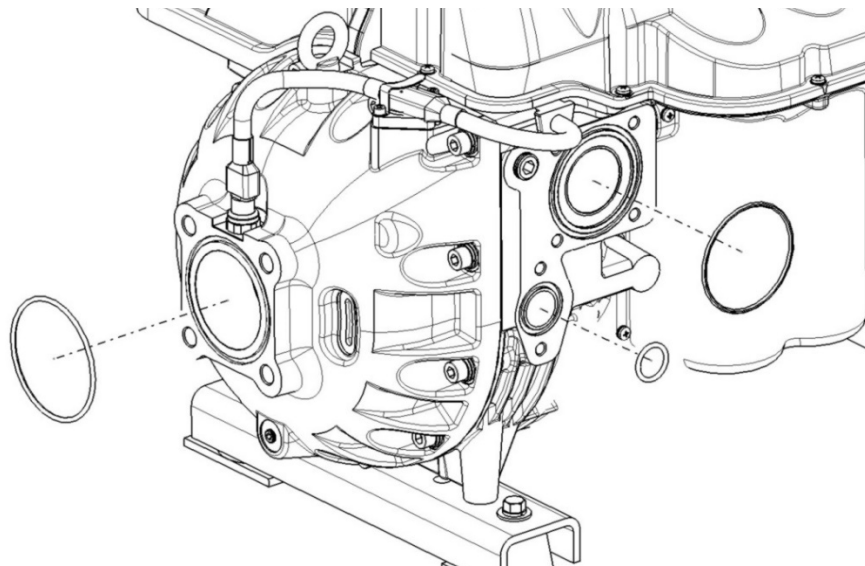

Figure 1 Suction, Discharge & Economizer

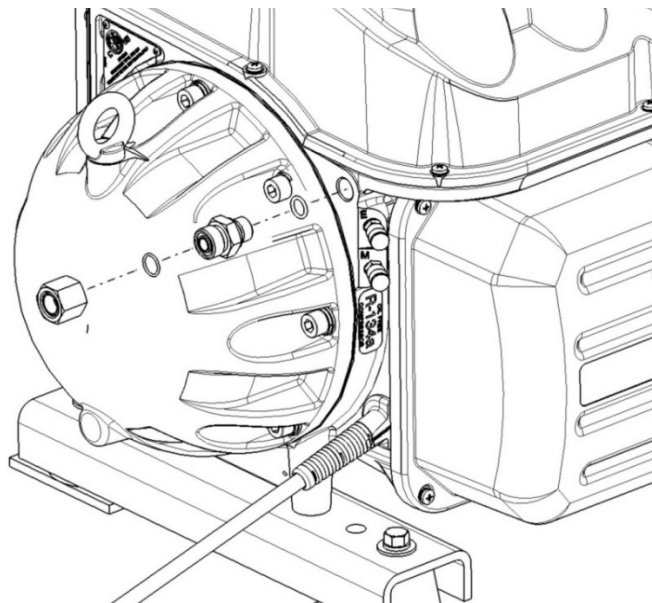









Figure 2 Cooling Adapter External & Internal

4 - Kit Contents

Kit	100327, 100329	
QTY	Part(s) Description	Picture(s)
1	O-RING Suction	
1	O-RING Discharge	
2	O-RING Economizer NOTE: There are two (2) different sized economizer O-rings; one is for the TT300/TG230 and the other is for all other TT/TG models.	
1	O-RING COOLING LINE, INTERNAL	
1	O-RING COOLING LINE, EXTERNAL	
2	LUBRICATION-SUPER-O-LUBE-2G	

Kit	100155, 100555	
QTY	Part(s) Description	Picture(s)
1	O-RING Suction	
1	LUBRICATION-SUPER-O-LUBE-2G	

Danfoss can accept no responsibility for possible errors in catalogues, brochures and other printed material. Danfoss reserves the right to alter its products without notice. This also applies to products already on order provided that such alterations can be made without subsequential changes being necessary in specifications already agreed. All trademarks in this material are property of the respective companies. Danfoss and the Danfoss logotype are trademarks of Danfoss A/S. All rights reserved.