



KIT O-RINGS FOR IGBT ASSEMBLY FOR TT300/TG230 COMPRESSORS

100310, 100310-2



Installation and servicing of Danfoss Turbocor® compressors by qualified and product trained personnel only. Follow these instructions and sound refrigeration/electrical/servicing practices relating to installation, commissioning, maintenance and service.

<p>Consult the appropriate DTC Service Manual on turbocor.danfoss.com for detailed service instructions.</p>	<p>Never power compressor without covers in place and secured.</p> <p>Removing the mains input cover will expose you to a voltage hazard of up to 575V. Ensure the mains input power is off and locked out before removing cover.</p> <p>Before removing top cover, wait at least 20 minutes after isolating AC power to allow the high voltage capacitors to discharge.</p>	<p>Always wear appropriately rated safety equipment when working around equipment and/or components energized with high voltage.</p> <p>This equipment contains hazardous voltages that can cause serious injury or death.</p>	<p>Recover all refrigerant from compressor in accordance with local codes and ensure pressure is fully vented before the removal of refrigerant containing components.</p>
--	---	---	---

1 - Introduction

O-RINGS FOR IGBT ASSEMBLY Removal and installation. (Exclusively for TT300/TG230 compressors).

2 - Removing Refrigerant from Compressor:

- Isolate the compressor and recover refrigerant from compressor in accordance with local codes and practices.

3 - O-rings Removal Instructions:

NOTE: Refer to the current Service Manual for more details in removal and installation.

1. Isolate compressor power and lock out in accordance with local codes and practices.
2. Remove the mains cover only.
3. Using an appropriately rated volt meter, confirm that the AC voltage is isolated.
4. Wait at least 20 minutes for the DC bus capacitors to discharge.

DANGER: Do NOT touch any components when removing the top cover. This is particularly true for compressors with CE covers because they are coated on the outside for the express purpose of being conductive

5. Remove the Top Cover by releasing the nine (9) screws that secure the cover, taking particular care not to touch ANY components underneath.
6. Using an appropriately rated volt meter, check the DC bus bars for voltage level. If the voltage is above 5VDC, wait five (5) minutes and recheck until 5VDC or below is achieved.
7. Remove the Capacitor Cover by releasing the six (6) screws that secure the cover.

8. For F Series and later compressors, remove the Soft Start Temperature Harness. Refer to Figure 1 (Soft Start J9 Connector).

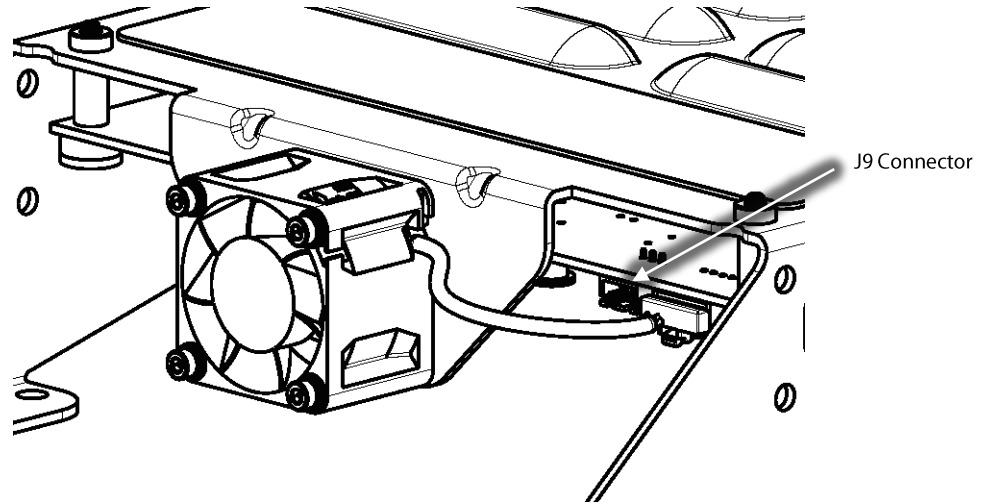

Figure 1 – Soft Start J9 Connector

9. Remove the cable tie securing the Soft Start ground cable to the AC/DC cable.
10. Disconnect the Soft Start ground wire by removing the top nut and mains input ground wire from the ground post on the compressor housing at 3-phase connection point. Refer to Figure 2 (Ground Location).

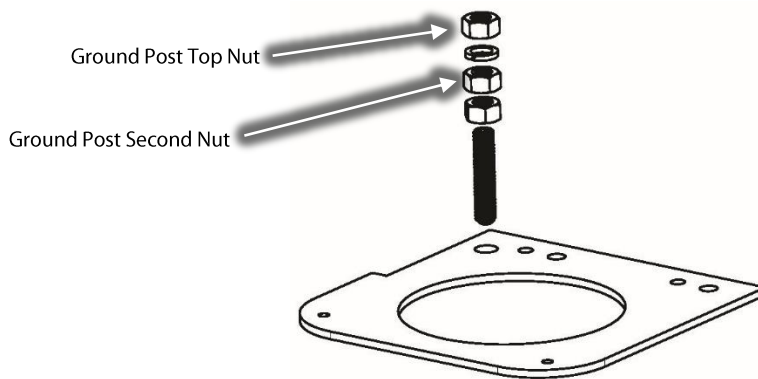

Figure 2 – Ground Location

- Remove the fasteners that secure the Soft Start mounting bracket to the compressor. Refer to Figure 3 (Soft Start Mounting Screws).

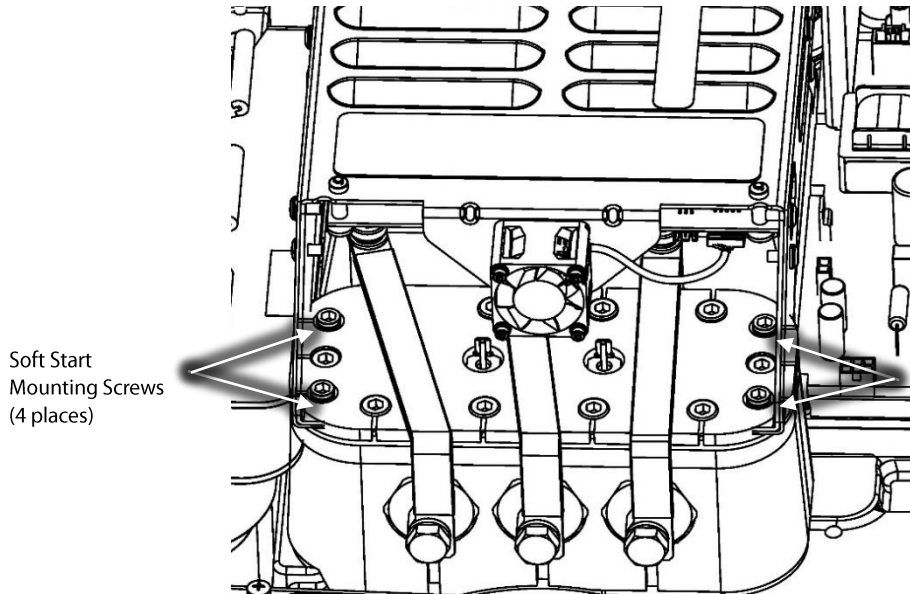

Figure 3 – Soft Start Mounting Screws

- Lift the Soft Start and turn it over, placing it board-side up on the AC Bus Bars. Refer to Figure 4 (Soft Start Lift).

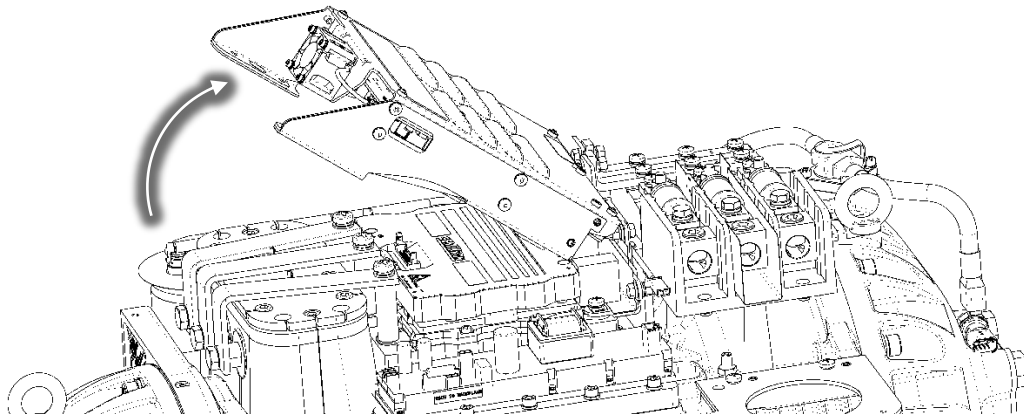

Figure 4 – Soft Start Lift

- Unplug the cable connectors from the Soft Start board. Refer to Figure 5 (Soft Start Harness Removal).

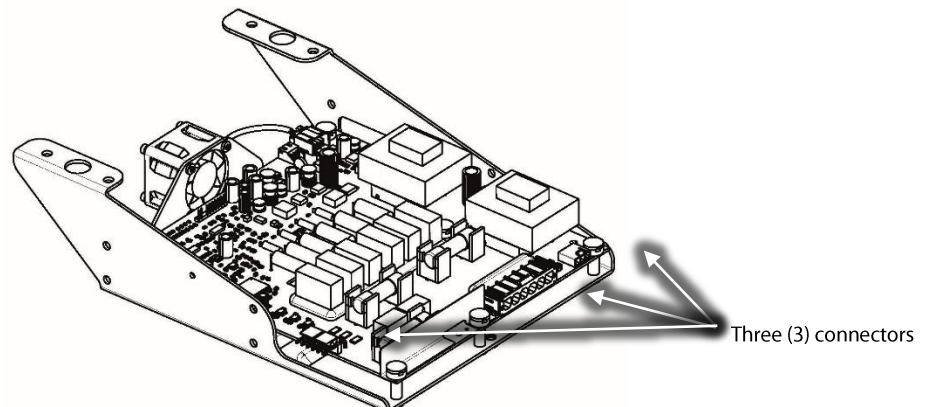

Figure 5 – Soft Start Harness Removal

14. Place the Soft Start board aside.
15. Unplug the Soft Start SCR Gate cable harness from the SCRs noting its orientation. Refer to Figure 6 (Soft Start SCR Gate Cable Harness Removal) for the location of the connectors on the SCRs.

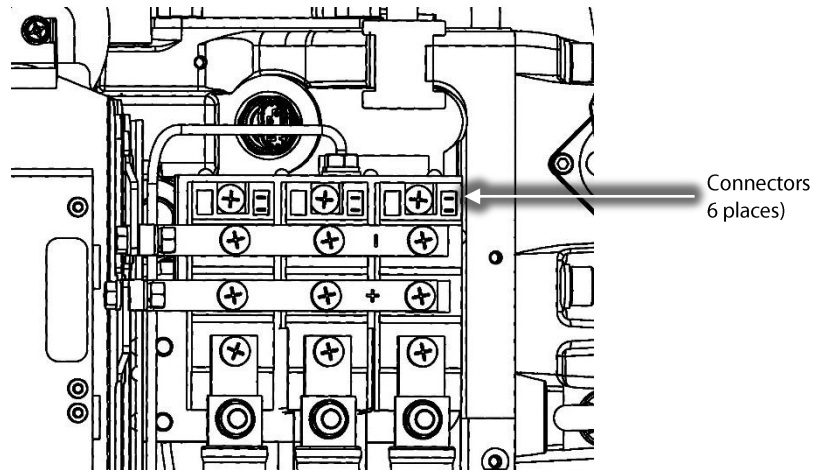

Figure 6 – Soft Start SCR Gate Cable Harness Removal

16. Remove the DC Bus Bars from the SCRs. Refer to Figure 7 (DC Bus Bar Removal).

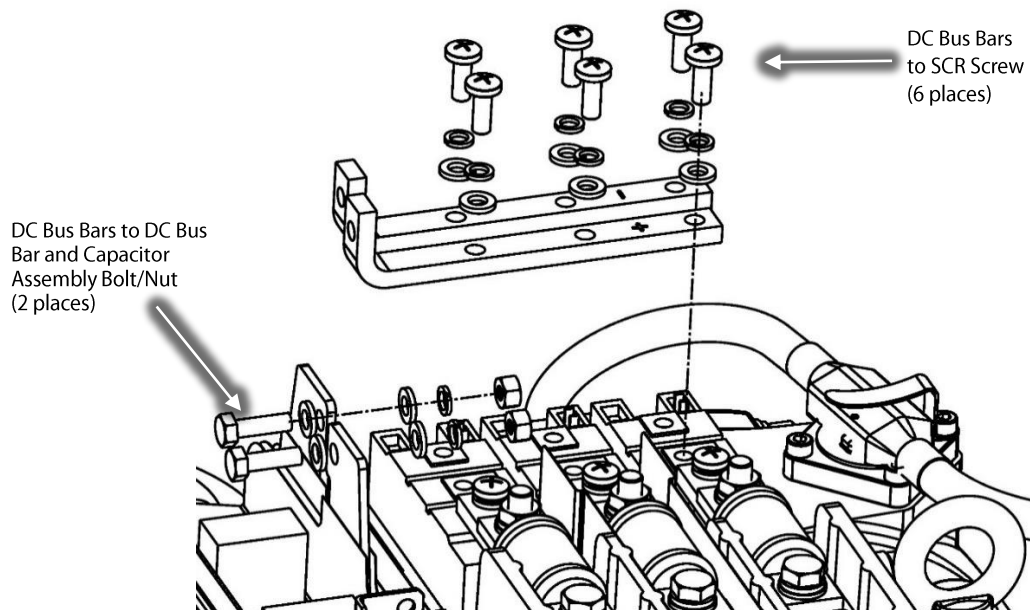

Figure 7 – DC Bus Bar Removal

17. Remove the three (3) fasteners that connect the Fast Acting Fuses to the SCR's and, noting their orientation, the 3-Phase input wires to the Soft Start AC/DC cable harness. Refer to Figure 8 (Fuse Block Assemblies).
18. Remove the two (2) fasteners from each of the three (3) fuse block assemblies and set aside the fuse assemblies. Refer to Figure 8 (Fuse Block Assemblies) and Figure 9 (Mylar Removal).

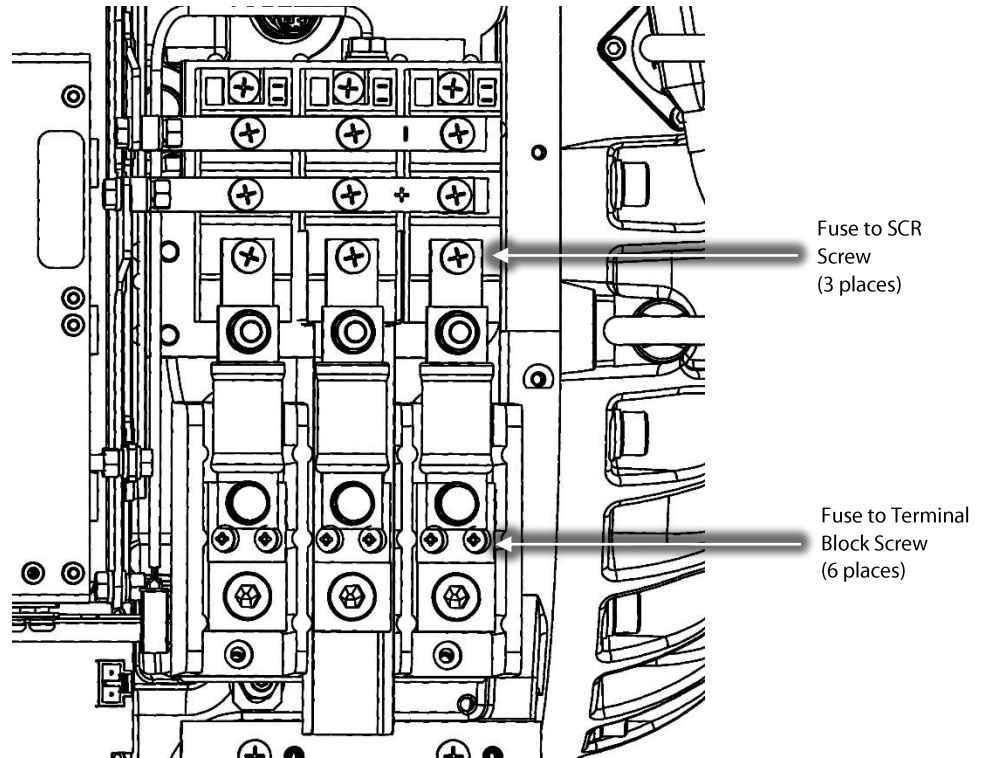

Figure 8 – Fuse Block Assemblies

19. Remove the insulating Mylar from the middle Terminal Block and set aside. Refer to Figure 9 (Mylar Removal).

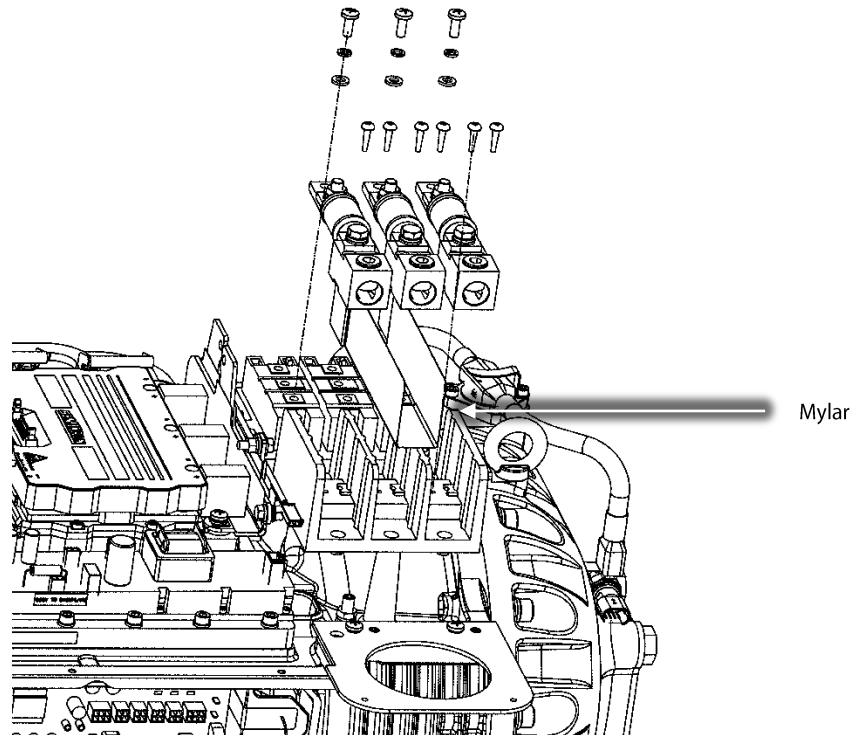

Figure 9 – Mylar Removal

20. Disconnect the DC+ and DC- of the Soft Start harness from the DC bus assembly noting the orientation. Refer to Figure 10 (DC+ and DC- Soft Start Harness Removal).

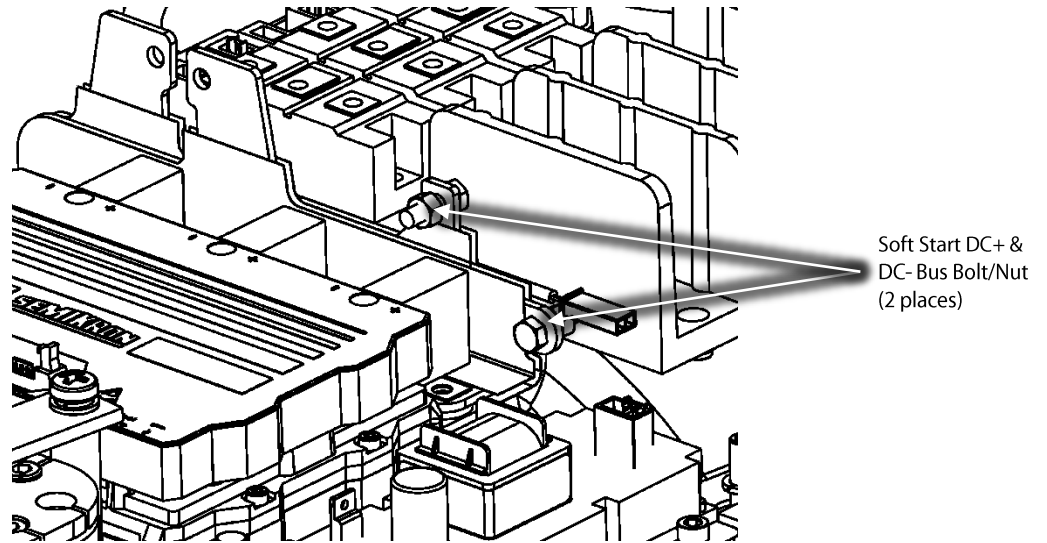

Figure 10 – DC+ and DC- Soft Start Harness Removal

21. Disconnect the snubber capacitors from the Inverter noting the leg orientation of one leg is longer than the other. Refer to Figure 11 (Snubber Capacitor Removal).

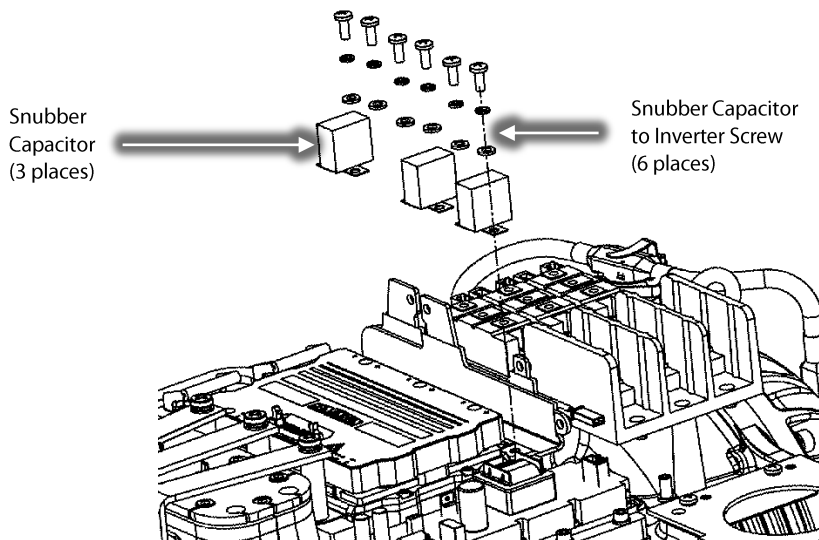

Figure 11 – Snubber Capacitor Removal

22. Remove the nylon nuts and foil at the base of the DC capacitor assembly, under the main compressor housing. Refer to Figure 12 (Capacitor Nut Removal).

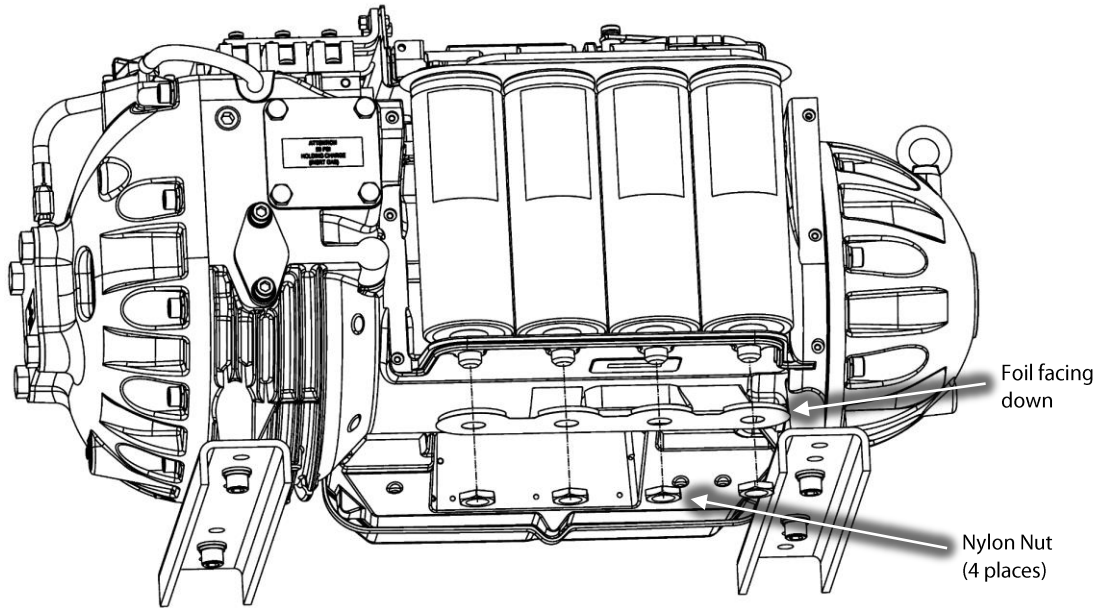

Figure 12 – Capacitor Nut Removal

23. Carefully lift the DC Bus Bar and Capacitor Assembly out as an assembly. Refer to Figure 13 (Capacitor Assembly Removal).

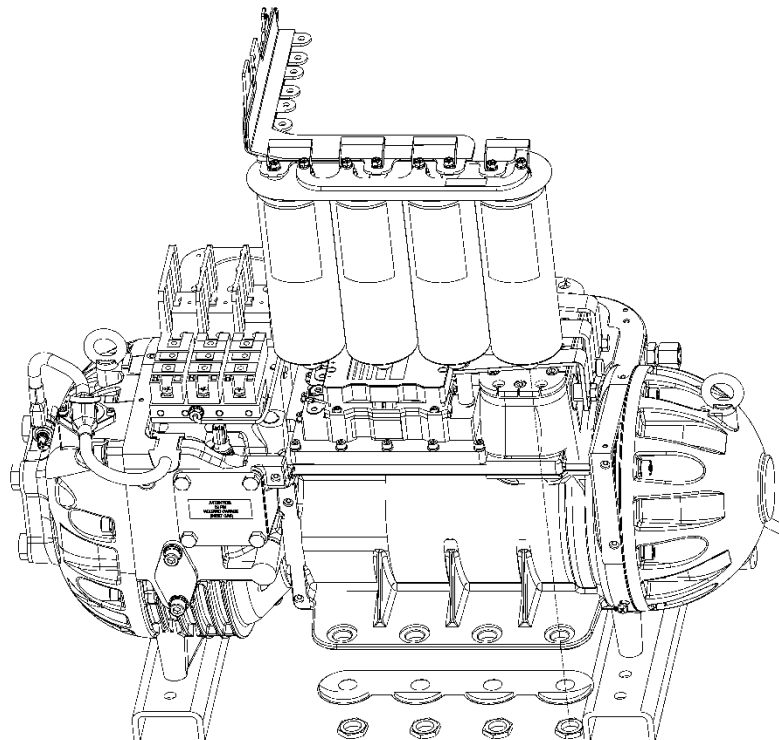

Figure 13 – Capacitor Assembly Removal

24. Remove the insulating Mylar from the Inverter if applicable. Refer to Figure 14 (Mylar Removal).

NOTE: This step only applies to Revision "F" and earlier TT300/TG230 compressors. Revision "G" and later compressors contain Mylar that is integrated into the DC Bus Bars and Capacitor Assembly.

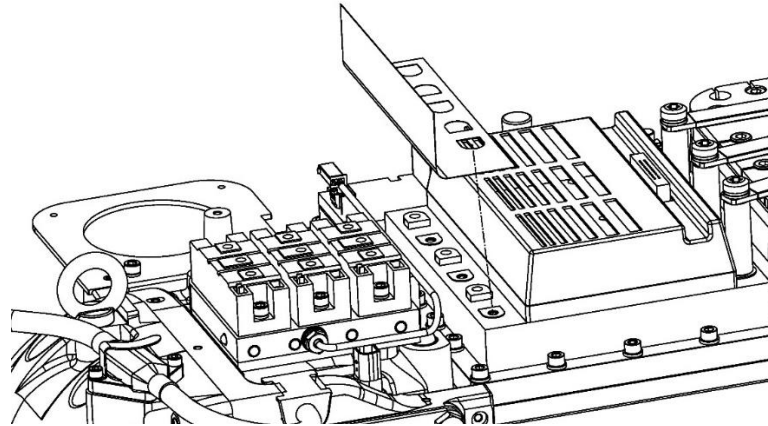

Figure 14 – Mylar Removal

25. Remove the Motor Bus Bar screws from the Inverter. Refer to Figure 15 (Copper Tube Removal).

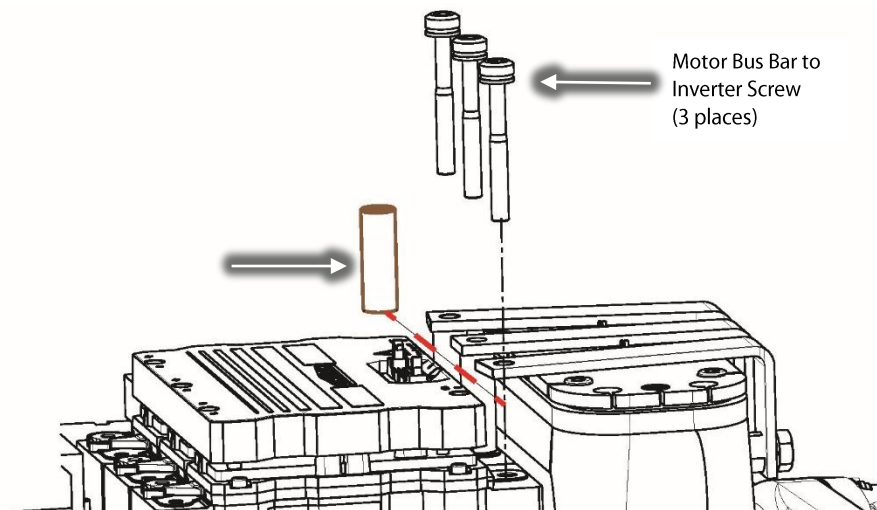

Figure 15 – Copper Tube Removal

26. Remove the Inverter Cable Harness from the top of the Inverter. Refer to Figure 16 (Inverter Harness Removal).

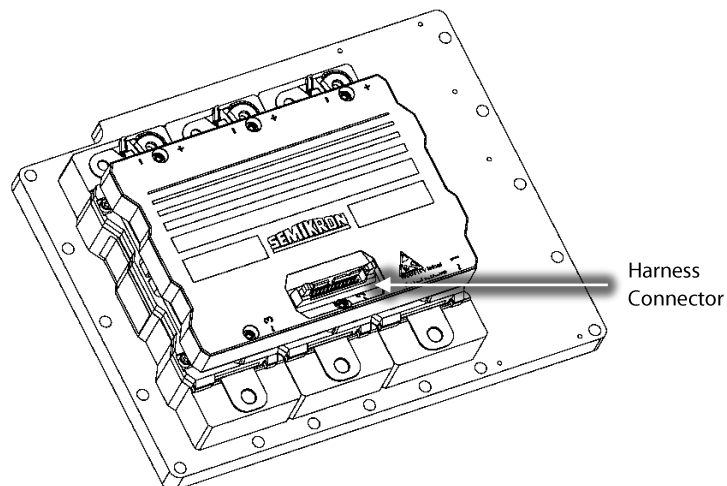

Figure 16 – Inverter Harness Removal

27. Disconnect all wiring connections from the HV DC-DC. Refer to Figure 17 (DC-DC Harness Removal).

NOTE: There is no need to remove the HV DC-DC converter from the Inverter heat sink plate.

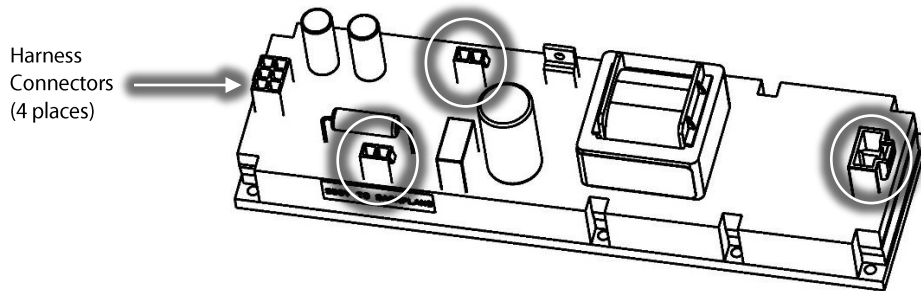

Figure 17 – DC-DC Harness Removal

28. Loosen the screw containing the Retainer Clip and rotate the clip to allow for the connector to be removed. Refer to Figure 18 (Retainer Clip Rotation).

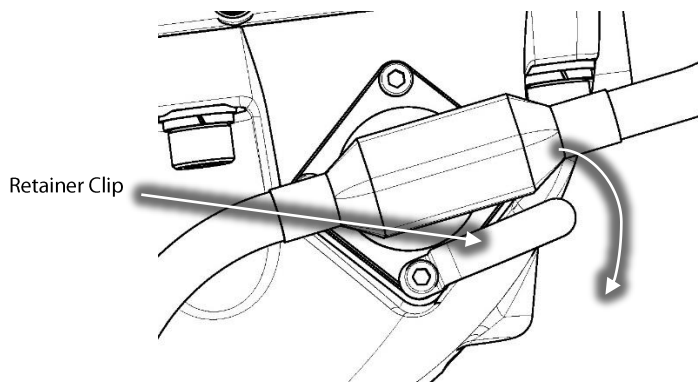

Figure 18 – Retainer Clip Rotation

Disconnect the harness from the SCR temperature sensor, discharge P/T sensor, IGV motor connection, and the suction P/T sensor. Set the Compressor Controller Cable Harness aside. Refer to Figure 19 (Cable Harness Compressor Controller Removal).

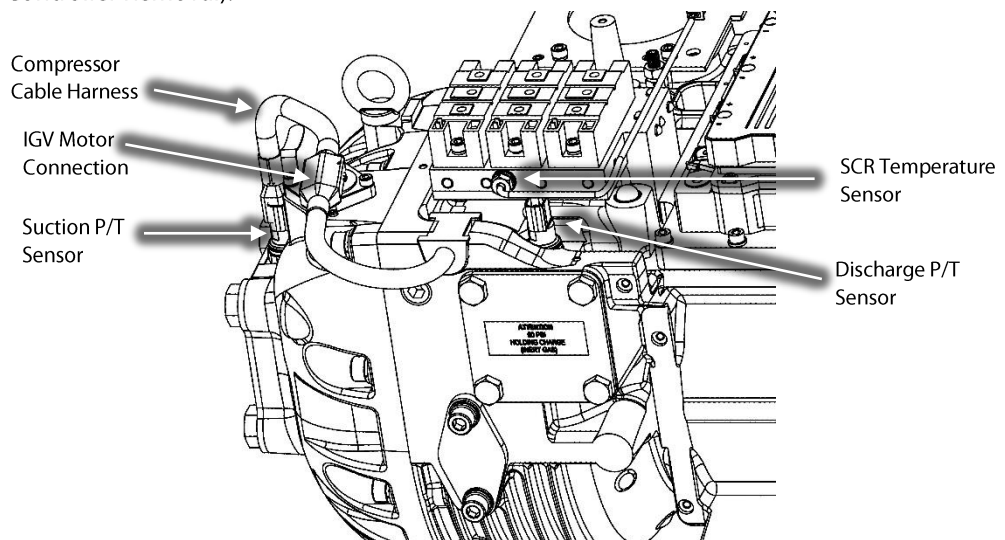

Figure 19 – Cable Harness Compressor Controller Removal

29. Remove the fasteners that secure the Inverter to the compressor main housing. Refer to Figure 20 (Inverter Removal).
30. Carefully, remove the Inverter and discard the two (2) O-rings underneath. (Note that the SCR cooling manifold will be attached to the Inverter cooling plate.)

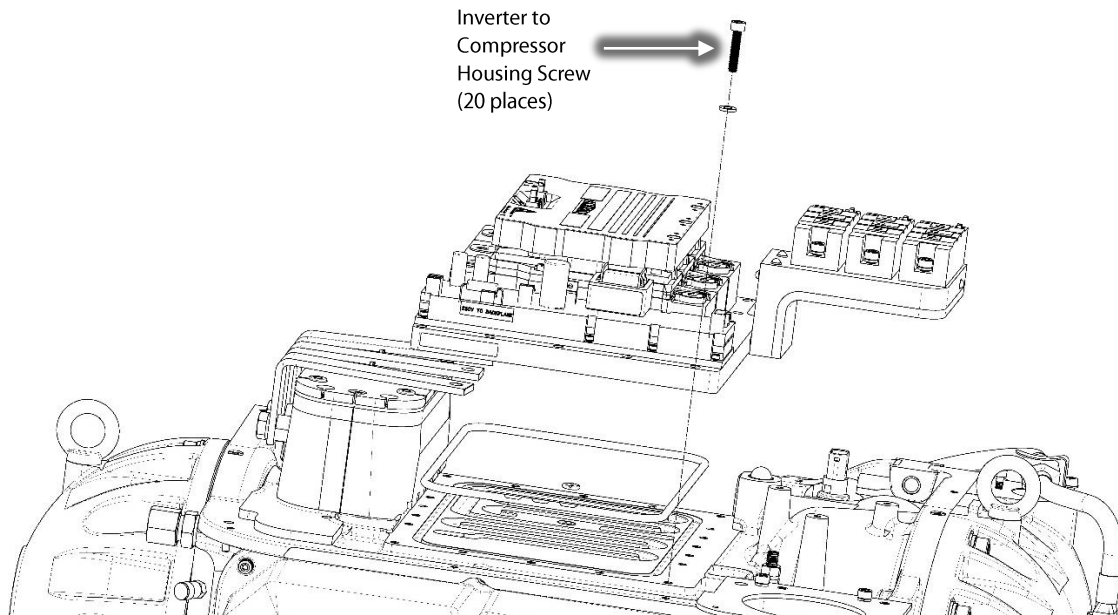

Figure 20 – Inverter Removal

31. Carefully remove the SCR cooling manifold foam insulation in order to gain access to the two (2) screws shown in Figure 21 (SCR Cooling Manifold Removal).

NOTE: Do not completely remove the foam insulation, only pull back what is needed to access the two (2) screws.

32. Remove the two (2) screws indicated in Figure 21 (SCR Cooling Manifold Removal) and carefully remove the SCR Cooling Manifold.
33. Remove and discard the two (2) O-rings present after removal of the SCR cooling manifold from the Inverter Cooling Manifold.

NOTE: The SCRs and the DC-DC do not need to be removed from the Inverter Cooling Plate and SCR Cooling Manifold.

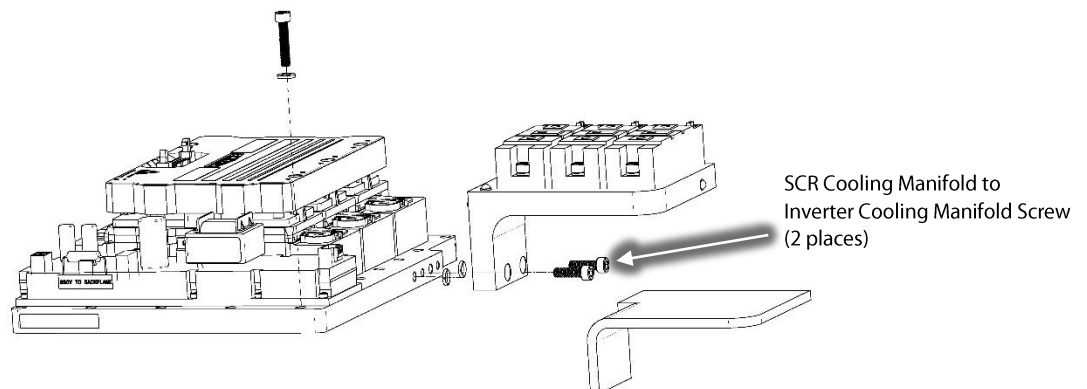

Figure 21 – SCR Cooling Manifold Removal

4 - O-rings Installation Instructions:

1. Apply O-Lube to the O-rings provided and install them into the SCR cooling manifold. Refer to Figure 22 (SCR Cooling Manifold O-ring Installation).

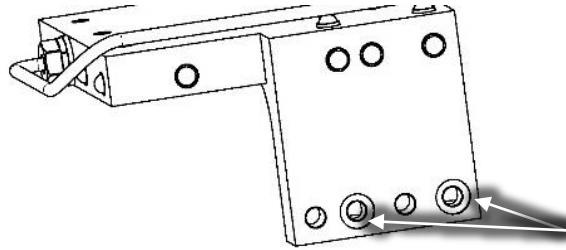

Figure 22 –SCR Cooling Manifold O-ring Installation

2. Reinstall the SCR cooling manifold to the Inverter cooling manifold using the two new (2) fasteners and torque to 7 Nm (62 in.lb.). Refer to Figure 23 (SCR Cooling Manifold Installation).
3. Reinstall the insulation onto the backside of the SCR Cooling Manifold.

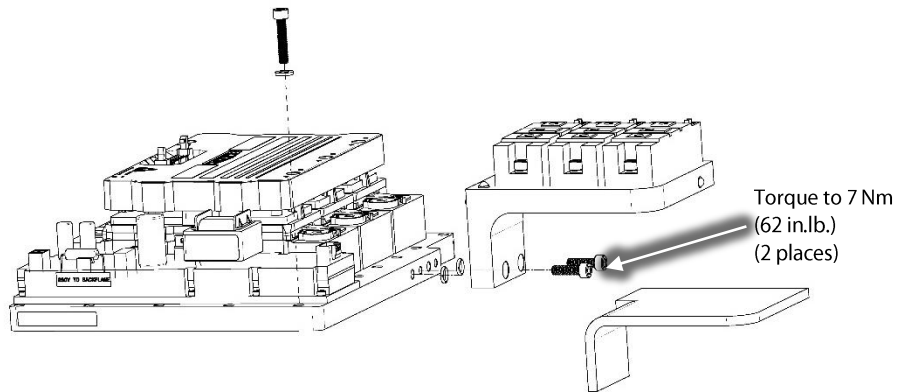

Figure 23 – SCR Cooling Manifold Installation

4. Clean the O-ring grooves in the compressor housing.
5. Apply O-Lube to the Inverter O-ring provided and place the O-ring in the compressor housing groove. Refer to Figure 24 (Inverter O-ring Installation) for this and the following step.
6. Install the small O-ring into the motor cooling port.

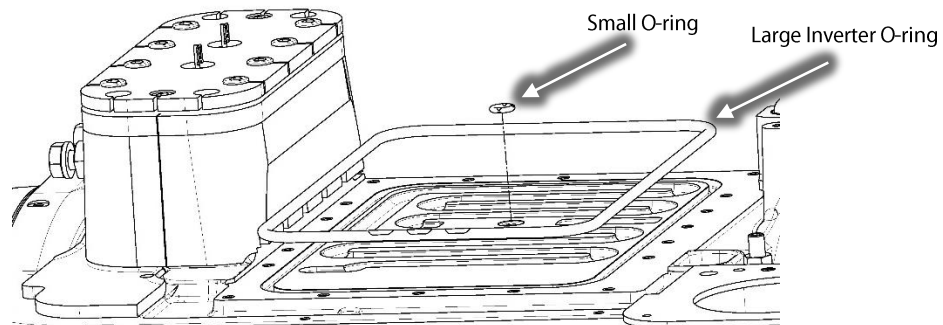

Figure 24 – Inverter O-ring Installation

- Carefully, install the Inverter on the compressor housing with the SCR temperature sensor cable run underneath the SCR cooling manifold. Refer to Figure 25 (Inverter Installation).

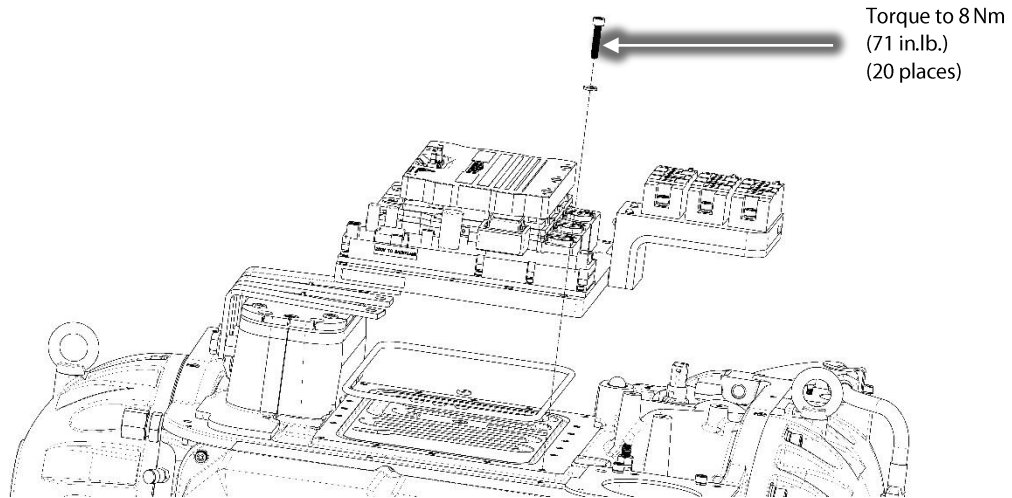

Figure 25 – Inverter Installation

- Install the provided Inverter fasteners in a diagonal pattern and torque to 3 Nm (27 in.lb.) on the first pass then to 8 Nm (71 in.lb.) on the second pass. Refer to Figure 26 (Inverter Screw Locations).

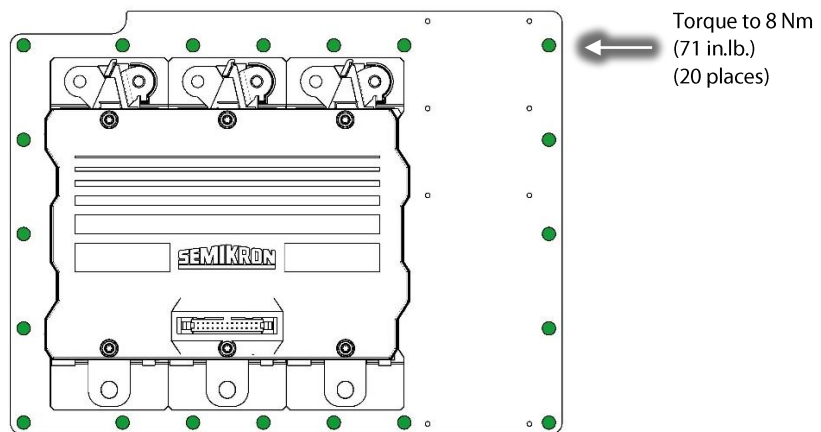

Figure 26 – Inverter Screw Locations

- Leak test and evacuate the compressor in accordance with industry standards.
- Reconnect the SCR temperature sensor, discharge P/T sensor, IGV motor connection, and the suction P/T sensor.
- Rotate the Retainer Clip until it is directly above the IGV Connector and torque the screw to 5 Nm (44 in.lb.). Refer to Figure 27 (Retainer Clip Rotation).

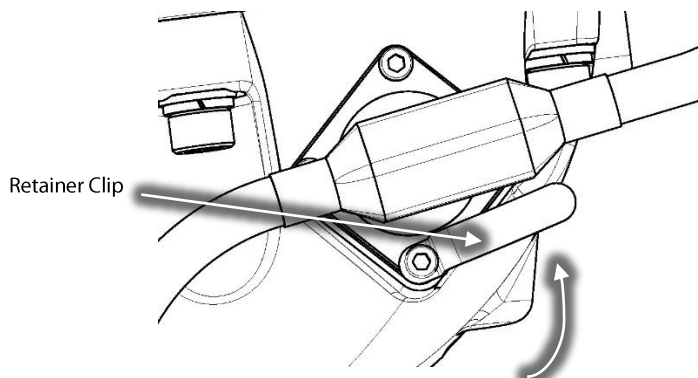

Figure 27 – Retainer Clip Rotation

12. Reinstall the three (3) copper tubes and torque the screws to 14 Nm (10 in.lb.). Refer to Figure 28 (Copper Tube Installation).

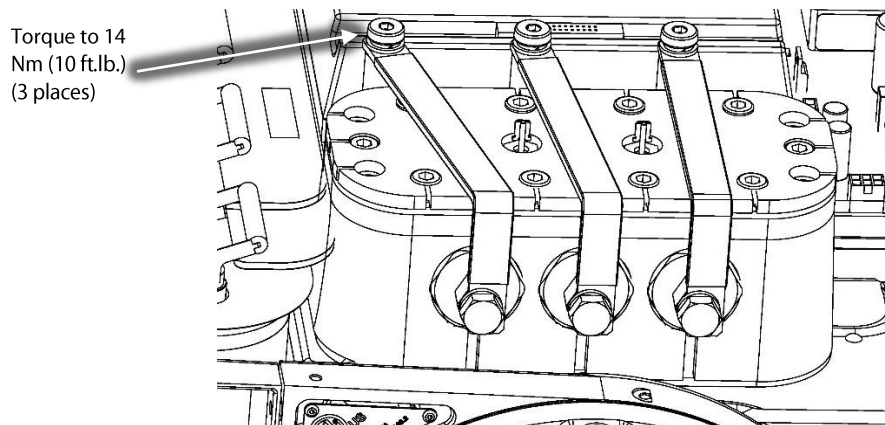

Figure 28 – Copper Tube Installation

13. Reinstall the DC Bus Bar and Capacitor Assembly over the Inverter. Then reconnect the snubber capacitors to the Inverter noting the leg orientation and torque to specification. Starting from the DC Bus Capacitor side, torque to 7 Nm (62 in.lb). Refer to Figure 11 (Snubber Capacitor Removal).
14. Place the capacitor membrane foil side down, underneath the main compressor housing and then reinstall the nylon nuts to the base of the DC capacitor assembly, under the main compressor housing and torque to 7 Nm (62 in.lb). Refer to Figure 12 (Capacitor Nut Removal).
15. Reconnect the DC+ and DC- of the Soft Start harness from the DC bus assembly noting the orientation and torque to 10 Nm (7 ft.lb.). Refer to Figure 10 (DC+ and DC- Soft Start Harness Removal).
16. Reconnect the DC Bus Bars to the SCRs and torque to 5 Nm (44 in.lb.). Refer to Figure 7 (DC Bus Bar Removal).
17. Reconnect the two (2) DC Bus Bars to DC Bus Bar and Capacitor Assembly and torque to 10 Nm (7 ft.lb.). Refer to Figure 7 (DC Bus Bar Removal).
18. Reconnect all electrical connections to the HV DC-DC converter. Refer to Figure 17 (DC-DC Harness Removal).
19. Reinstall the Mylar in the middle of the Terminal Block. Refer to Figure 29 (Main Power Mylar Insertion).

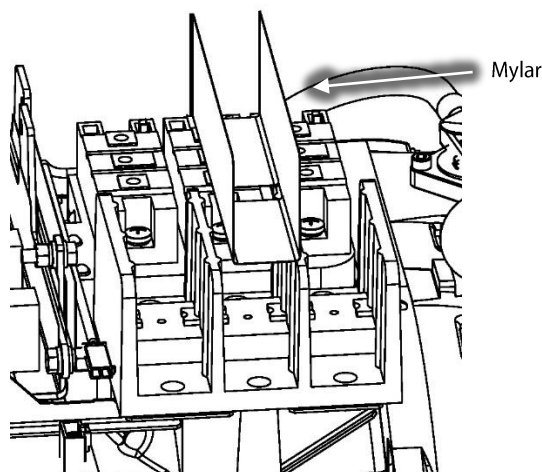

Figure 29 – Main Power Mylar Insertion

- Reinstall the three (3) fuse assemblies to the SCRs and the Mains Input Terminal Block. Torque the fasteners of the fuse assemblies to specification. Refer to Figure 30 (Fuse Assembly Installation).

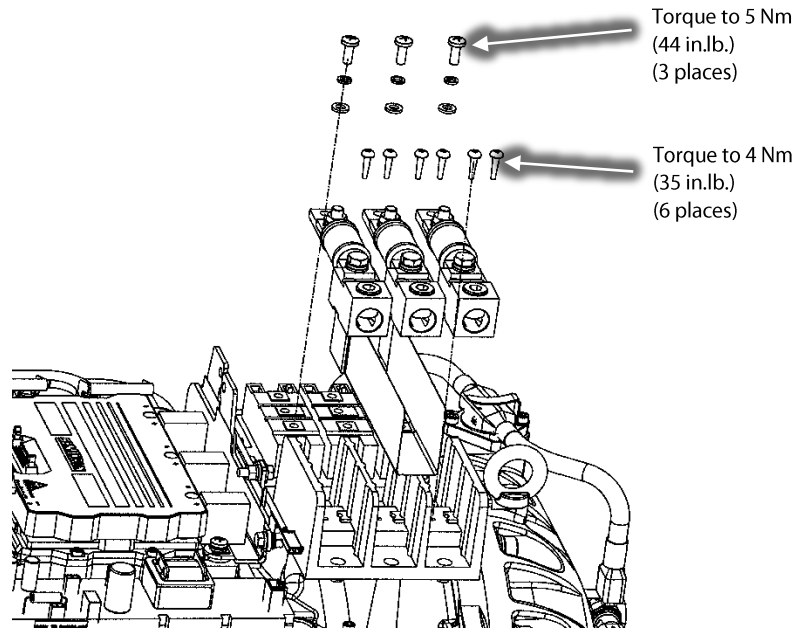

Figure 30 – Fuse Assembly Installation

- Connect the SCR Gate cable harness to the SCRs in the same orientation as noted during its removal.
- Reconnect all wiring harnesses to the Soft Start.
- Place the Soft Start into mounting position, secure to the compressor, and torque to 5 Nm (44 in.lb.).
- Route and connect the Soft Start ground wire to the ground post on the compressor housing at 3-phase connection point and torque the top nut to 10 Nm (7 ft.lb.).
- Install covers.

Capacitor Cover

- Place the Capacitor Cover and secure it with the long screw (M5 x 20) and flat washer in position number three (3) as shown in the following figure. Use five (5) remaining screws to secure the cover. Fasten according to the sequence in Figure 31 (Capacitor Cover Torque Sequence). Follow the sequence twice.

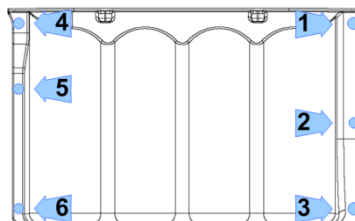

Figure 31 – Capacitor Cover Torque Sequence

Top and Mains Input Cover

- Ensure that no residue remains on the contact surfaces of Top Cover and casting sides.
- Place the Top Cover and secure it with the nine (9) M5x15 screws according to the following sequence. Follow the sequence twice. The first time, only fasten screws half way down to allow for adjustments. Torque to 13 in.lb. on the second pass. Refer to Figure 32 (Top Cover Torque Sequence).

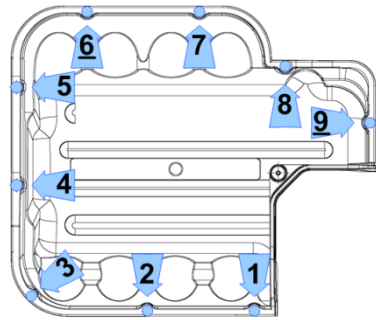

Figure 32 – Top Cover Torque Sequence

29. Ensure that no residue remains on the contact surfaces of the Mains Input Cover and casting sides.
30. Place the Mains Input Cover and secure it with the four (4) M5x15 screws. Tighten according to Figure 33 (Mains Input Cover Torque Sequence).

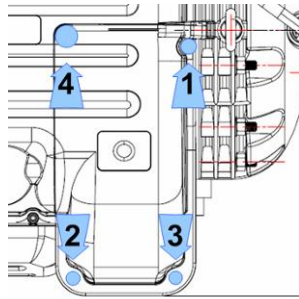

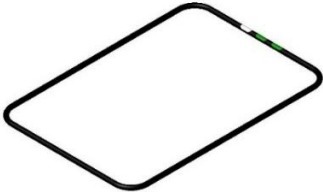





Figure 33 – Mains Input Cover Torque Sequence

31. Follow the sequence twice. The first time, only fasten screws to half way down to allow for adjustment. Torque to 13 in.lb. on the second pass. Fasten the # 4 screw only once and use caution as to not overtighten this screw.
32. Return the compressor to normal operation.

Torque Values	
Component	Torque Value
SCR Cooling Manifold to Inverter Cooling Manifold Screw	7 Nm (62 in.lb.)
Soft Start Mounting Screw	5 Nm (44 in.lb.)
Inverter to Compressor Housing Screw	8 Nm (71 in.lb.)
Motor Bus Bar to Inverter Screw	14 Nm (10 ft.lb.)
Soft Start DC+ & DC- to DC Bus Bolt/Nut	10 Nm (7 ft.lb.)
Snubber Capacitors to Inverter Screw	7 Nm (62 in.lb.)
Nylon Nut	7 Nm (62 in.lb.)
DC Bus Bars to DC Bus Bar and Capacitor Assembly	10 Nm (7 ft.lb.)
DC Bus Bars to SCR Screw	5 Nm (44 in.lb.)
Fuse to SCR Screw	5 Nm (44 in.lb.)
Fuse to Terminal Block Screw	4 Nm (35 in.lb.)
Ground Post Top Nut	10 Nm (7 ft.lb.)
Ground Post Second Nut	7 Nm (62 in.lb.)

5 - Kit Contents

QTY	Part(s) Description	Picture(s)
2	O-RING #2-011	
1	O-RING #2-109	
1	O-RING #2-377	
20	SCREW M6X30 S/HD CAP	
20	WASHER M6 FLAT	
2	SCREW M6X20 SOCKET HEAD CAP	
1	LUBRICATION-SUPER-O-LUBE-2G	

Danfoss can accept no responsibility for possible errors in catalogues, brochures and other printed material. Danfoss reserves the right to alter its products without notice. This also applies to products already on order provided that such alterations can be made without subsequential changes being necessary in specifications already agreed. All trademarks in this material are property of the respective companies. Danfoss and the Danfoss logotype are trademarks of Danfoss A/S. All rights reserved.