



KIT Refrigerant Sticker “513A”

100374



Installation and servicing of Danfoss Turbocor® compressors by qualified and product trained personnel only. Follow these instructions and sound refrigeration/electrical/servicing practices relating to installation, commissioning, maintenance and service.

<p>Consult the appropriate Danfoss Turbocor Compressors Inc. (DTC) Service Manual on turbocor.danfoss.com for detailed service instructions.</p>	<p>Never power compressor without covers in place and secured.</p> <p>Removing the mains input cover will expose you to a voltage hazard of up to 575V. Ensure the mains input power is off and locked out before removing cover.</p> <p>Before removing top cover, wait at least 20 minutes after isolating AC power to allow the high voltage capacitors to discharge.</p>	<p>Always wear appropriately rated safety equipment when working around equipment and/or components energized with high voltage.</p> <p>This equipment contains hazardous voltages that can cause serious injury or death.</p>	<p>Recover all refrigerant from compressor in accordance with local codes and ensure pressure is fully vented before the removal of refrigerant containing components.</p>
--	---	---	---

1 - Introduction:

REFRIGERANT STICKER KIT removal and installation instructions.

The following instruction includes the how to remove and replace the refrigerant sticker on all TT and TTH compressors. This step should be performed prior to the commissioning of the compressor.

2 - Suggested Tools:

The following tools are suggested to remove and replace the refrigerant stickers:

- Razor blade

3 - Removal Instructions:

1. Locate the existing refrigerant sticker. Refer to Figure 1.

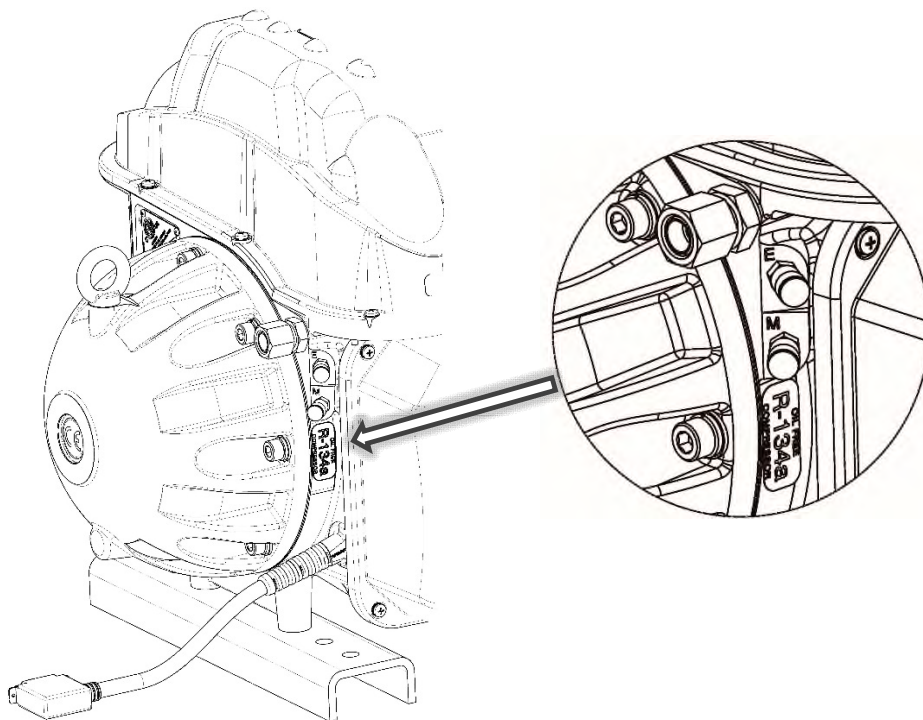

Figure 1 – Sticker Location

2. Carefully remove and discard the existing sticker (if present).

NOTE: It may be necessary to use a razor blade.

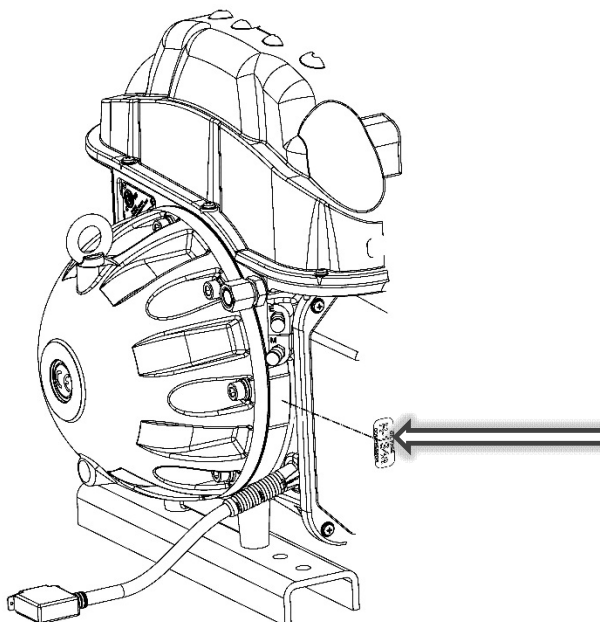

Figure 2 – Sticker Removed

4 - Application Instructions:

1. Ensure the surface where the sticker was removed is clean and oil free.
NOTE: It may be necessary to use a solvent (e.g., alcohol) to remove the remaining sticker adhesive.

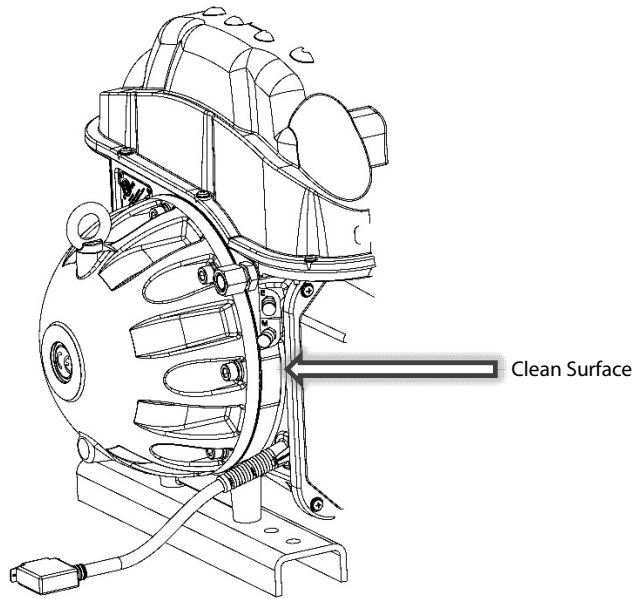

Figure 3 – Sticker Surface

2. Remove the backing from the new refrigerant sticker.
3. Adhere it to the same location as the one that was previously removed. Be sure that it is in the same orientation as the one in Figure 1.
4. Gently rub over the sticker to ensure it is properly adhered to the compressor housing.

5 - Kit Contents:

QTY	Part(s) Description	Picture(s)
10	R-513A Refrigerant Sticker	

Danfoss can accept no responsibility for possible errors in catalogues, brochures and other printed material. Danfoss reserves the right to alter its products without notice. This also applies to products already on order provided that such alterations can be made without subsequential changes being necessary in specifications already agreed. All trademarks in this material are property of the respective companies. Danfoss and the Danfoss logotype are trademarks of Danfoss A/S. All rights reserved.