



KIT SEMIKRON SKIIP IGBT DRIVER

100518 & 100518-1.

 <p>Installation and servicing of Danfoss Turbocor® compressors by qualified and product trained personnel only. Follow these instructions and sound refrigeration/electrical/servicing practices relating to installation, commissioning, maintenance and service.</p>			
<p>Consult the appropriate Danfoss Turbocor Compressors Inc. (DTC) Service Manual on turbocor.danfoss.com for detailed service instructions.</p>	<p>Never power compressor without covers in place and secured.</p> <p>Removing the mains input cover will expose you to a voltage hazard of up to 575V. Ensure the mains input power is off and locked out before removing cover.</p> <p>Before removing top cover, wait at least 20 minutes after isolating AC power to allow the high voltage capacitors to discharge.</p>	<p>Always wear appropriately rated safety equipment when working around equipment and/or components energized with high voltage.</p> <p>This equipment contains hazardous voltages that can cause serious injury or death.</p>	<p>Recover all refrigerant from compressor in accordance with local codes and ensure pressure is fully vented before the removal of refrigerant containing components.</p>

1 - Introduction:

SEMIKRON SKIIP 613 IGBT DRIVER BOARD replacement. The driver boards packaged in the two kits look identical, however, they are not interchangeable. Refer to the kit applications below.

- Kit 100518 – Applies to TT350, TT400, TT500, TT700, TG310, TG390, & TG520 compressors
- Kit 100518-1 – Applies to TT300 & TG230 compressors

This kit contains the Driver Board for the Inverter. Please refer to our Service Manual for details regarding the replacement of the Driver Board.

We have made the **TTS/TGS/TTH/TGH Service Manual** available to anyone. To access the manual, you may scan the applicable QR code below or you may go to our DTC website at www.turbocoroem.com. At the top of the page there is a pull-down menu called “Quick Links.” Click this menu and select the appropriate service manual.

Refer to the applicable QR code below to download the TTS/TGS/TTH/TGH Service Manual.

English



Chinese



2 - DRIVER BOARD Removal Instructions:

- ⚠ Refer to the Service Manual for proper electrostatic discharge (ESD) handling of electronic components. It is essential that proper ESD precautions are taken.
- 1. Isolate the compressor power.
- 2. Remove the AC Bus Bars.
- 3. Remove the Soft Start.
- 4. Remove the Snubber Capacitors.
- 5. Remove the DC Bus Assembly.
- 6. Remove motor bus bars.
- 7. Remove the six (6) screws using a T15 Torx bit. Begin on the outside and work towards the center.
- 8. Carefully lift the driver board vertically.
- 9. Set aside the driver screws for re-use.
- 10. Properly discard the old driver board.

3 - DRIVER BOARD Installation Instructions:

NOTE: Use *extreme care* when removing the new driver board and cover from the packaging. The cover snaps into place over the driver board but could separate. Be sure to hold both to avoid dropping the driver board if separation occurs. If they do become separated, carefully snap the cover back into place prior to assembly. ESD protection must be worn when handling the driver board.

CAUTION: Do not move or touch any spring pins unless they are not in proper alignment. Damage or misalignment of spring pins can cause failure of the entire Inverter module.

- 1. Verify that all spring pins are present and that they are in proper alignment. There should be a total of 39 pins. There are two (2) different length spring pins, if any are replaced, be sure to replace with the same length spring pin.
- 2. Replace any defective spring pins (bent pin head or inconsistent height on top with others) with new ones. Only do this when absolutely necessary. When removing the spring pins, use small needle-nose pliers and gently pull straight up with no lateral movement.

NOTE: Do not attempt to straighten or repair any damaged spring pins.

- 3. Discard the defective spring pins and inspect the IGBT for any foreign objects.
- 4. Insert the new pins carefully and be sure that they line up in the notches.
- 5. For proper alignment, insert two (2) of the screws in opposite corners of the Driver Board.
- 6. Align the new Driver Board over the IGBT module with the connector towards motor stator output bus bar (the shape of Driver Board must be aligned with IGBT Press Plate shape).
- 7. Insert the screws into the corresponding Press Plate holes.
- 8. Moving in a vertical direction only, lower the Driver Board down on the IGBT module, do not allow for any lateral movement.

WARNING: Any lateral movement may damage the spring pins.





- 9. Insert the remaining screws and tighten the screws from center outward according to Figure 8 (Initial Tightening Pass Sequence). This will be the first pass and the screws should only be snug and not torqued at this step.
- 10. Using an appropriately rated torque wrench, tighten the screws from center outward (same sequence as previous step) to 1.5 Nm (13.2 in. lbs.).

NOTE: It is recommended to verify Inverter functionality using an inverter tester prior to reassembly of the top-side electronics.

- 11. Install the Motor Bus bars.
- 12. Install the DC Bus Assembly.
- 13. Install the Snubber Capacitors.

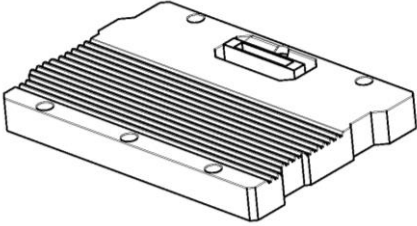
14. Install the Soft Start.
15. Install the AC Bus Bars.
16. Connect all cable harnesses.
17. Install the top covers.
18. Return the compressor to normal operation.

4 - Kit Contents:

Kit	100518 & 100518-1	
QTY	Part(s) Description	Picture(s)
1	DRIVER BOARD AND COVER FOR SKiIP 613	
2	SCREW, EJOT 20MM, SKiIP 613	
2	SPRING PIN, SHORT, SKiIP 613	
2	SPRING PIN, LONG, SKiIP 613	
1	WRIST STRAP WITH 12 FT CORD	

Danfoss can accept no responsibility for possible errors in catalogues, brochures and other printed material. Danfoss reserves the right to alter its products without notice. This also applies to products already on order provided that such alterations can be made without subsequential changes being necessary in specifications already agreed. All trademarks in this material are property of the respective companies. Danfoss and the Danfoss logotype are trademarks of Danfoss A/S. All rights reserved.