

Operating Guide

# VLT® PTC Thermistor Card MCB 112

VLT® HVAC Drive FC 102, VLT® AQUA Drive FC 202, VLT® Automation  
Drive FC 302



**VLT®**  
AutomationDrive





## Contents

<b>1</b>	<b>Introduction</b>	<b>6</b>
1.1	Purpose of this Operating Guide	6
1.2	Additional Resources	6
1.3	Version History	6
1.4	Products Covered	6
1.5	Functional Overview	6
1.5.1	Intended Use	6
1.5.1.1	Markings of the Drive	7
1.5.2	Foreseeable Misuse	7
1.5.3	Thermal Motor Protection	7
1.5.4	ATEX ETR Thermal Monitoring	7
1.5.5	Tripping Function	8
1.5.6	Safe Separation	8
1.5.7	Safe Disconnection Principle	8
1.5.8	Safe Disconnection Principle Diagram	8
1.6	Motor Requirements	9
1.6.1	Motor Limits and Rules	9
1.6.2	Additional Motor Requirements	9
1.6.3	Approvals and Certifications	9
1.7	Abbreviations and Conventions	9
1.7.1	Abbreviations	9
1.7.2	Conventions	10
<b>2</b>	<b>Safety</b>	<b>11</b>
2.1	Safety Symbols	11
2.2	Qualified Personnel	11
2.3	Responsibilities of Users of Safety-related Power Drive Systems PDS (SR)	11
2.4	Protective Measures	11
2.5	Safety Precautions	12
<b>3</b>	<b>Installation</b>	<b>13</b>
3.1	Safety Instructions	13
3.2	Installing the VLT® PTC Thermistor Card MCB 112	13
3.3	Sensor Circuit Wire Requirements	14
3.4	Connecting Sensor Circuit Wires	15
3.5	Maximum Current on MCB 112	16
3.6	Wiring of STO	16

3.7	Assembly	17
<b>4</b>	<b>Commissioning</b>	<b>18</b>
4.1	Commissioning the Drive	18
4.2	Operation and Maintenance	18
4.2.1	Testing	18
4.2.2	Monitoring Sensor Resistance	18
4.2.3	Thermal Limitation Curve (Ex eb and Ex ec Motors Only)	19
4.3	Parameter Set-up	20
4.3.1	Alarm Handling	20
4.4	Parameter Set-up for Ex eb and Ex ec Motors	20
4.4.1	Overview of Ex eb and Ex ec Specific Parameters	20
4.4.2	Activate the ATEX ETR Monitor Function	21
4.4.3	Maximum Current Limit	21
4.4.4	Minimum Motor Frequency	21
4.4.5	Maximum Motor Frequency	22
4.4.6	Minimum Switching Frequency	22
4.4.7	Disable Protection Mode	22
4.4.8	Safe Torque Off Functionality	22
4.4.9	Functions, Alarms, and Warnings	23
<b>5</b>	<b>Application Examples</b>	<b>24</b>
5.1	Setting up the Option for Standard Use	24
5.2	Combination with Other Components using STO	25
<b>6</b>	<b>Maintenance and Troubleshooting</b>	<b>27</b>
6.1	Maintenance	27
6.2	Troubleshooting	27
6.2.1	Test the Sensor Circuit and Relay Function	27
6.2.2	Alarm/Warning Code List	27
6.2.3	Description of Alarm Word, Warning Word, and Extended Status Word	27
6.2.4	Alarm 68, Safe Stop	27
6.2.5	Warning 68, Safe Stop	27
6.2.6	Alarm 71, PTC 1 Safe Stop	27
6.2.7	Warning 71, PTC 1 Safe Stop	28
6.2.8	Alarm 72, Dangerous Failure	28
6.2.9	Unexpected Combinations	28
<b>7</b>	<b>Specifications</b>	<b>29</b>
7.1	Mains Supply	29

---

7.2	Control Inputs and Outputs	29
7.2.1	PTC Thermistor Connection X44/1+X44/2	29
7.2.2	Safe Stop Terminal 37, X44/12	29
7.2.3	Logic out, X44/10	29
7.3	Ambient Conditions	29
7.3.1	Environment	29
7.3.2	Testing Conditions	29
7.4	Other Specifications	30
7.5	Safety Characteristics of the Built-in MCB 112	30

---

# 1 Introduction

## 1.1 Purpose of this Operating Guide

This operating guide provides information for safe installation and commissioning of the VLT® PTC Thermistor Card MCB 112 used with a Danfoss VLT® drive with Safe Torque Off (STO).

VLT® PTC Thermistor Card MCB 112 is also referred to as MS 220 DA.

This operating guide is intended for use by qualified personnel only. To use the drive safely and professionally, read and follow the instructions, and pay particular attention to the safety instructions and general warnings. Keep this operating guide available with the drive at all times.

VLT® is a registered trademark.

## 1.2 Additional Resources

This manual is targeted at users already familiar with the VLT® drives. It is intended as a supplement to the manuals and instructions for download at <http://drives.danfoss.com/downloads/portal/>.

Read the instructions shipped with the drive and/or drive option before installing the unit, and observe the instructions for safe installation.

## 1.3 Version History

This guide is regularly reviewed and updated. All suggestions for improvement are welcome.

The original language of this guide is English.

**Table 1: Version History**

Version	Remarks
MG33V302	Editorial changes. Now covering the complete system.
AQ267038105120, version 0101	Update for compliance to ATEX directive 2014/34/EU and actual standards.

## 1.4 Products Covered

The VLT® PTC Thermistor Card MCB 112 is available for the following drives:

- VLT® HVAC Drive FC 102.
- VLT® AQUA Drive FC 202.
- VLT® AutomationDrive FC 302.

## 1.5 Functional Overview

### 1.5.1 Intended Use

The VLT® PTC Thermistor Card MCB 112 is intended to:

- Protect electrical motors against inadmissible heating due to overload.
- Protect explosion-protected motors in explosive atmospheres caused by:
  - gases, vapors, or mists, Zone 1 and Zone 2,
  - and/or in explosive atmospheres caused by dust, Zone 21 and Zone 22.

## N O T I C E

### MARKINGS

Refer to marking G for Zone 1 and Zone 2. Refer to marking D for Zone 21 and Zone 22.

All functions in the MCB 112 serve to protect both non-explosive-protected motors and explosive-protected motors in regular operation and in case of failure.

The VLT® PTC Thermistor Card MCB 112 is designed in accordance with EN 60947-8 (VDE 0660 part 0302). Only connect PTC thermistor sensors according to DIN VDE V 0898-1-401: 2020-03 (EN 60947-8).

**NOTICE**

**BUILT-IN OPTION**

The VLT® PTC Thermistor Card MCB 112 is only functional if it is built into the drive. The option cannot be used as a standalone.

**1.5.1.1 Markings of the Drive**

A sticker is delivered with the option as spare part or with the drive to signify ATEX certification. Apply this sticker to the front of the drive in which the ATEX module is integrated. This sticker indicates that the drive is ATEX certified.



Illustration 1: Label to Apply to Drive

**1.5.2 Foreseeable Misuse**

Any use not expressly approved by Danfoss constitutes misuse. This also applies to failure to comply with the specified operating conditions and applications.

Danfoss assumes no liability of any sort for damage attributable to improper use.

Only operate with explosion-protected 3-phase motors which are built, tested, and labeled separately for use with drives.

**⚠ WARNING ⚠**

**EXPLOSION DANGER**

Zone 0 and Zone 20 are not applicable to electrical motors. Using electrical motors in those zones can cause explosions.

- Only use electrical motors in:  
Zone 1/21.  
Zone 2/22.

**1.5.3 Thermal Motor Protection**

According to ATEX Directive 2014/34/EU and Standard EN 60079-14, motor overload protection is a requirement. The VLT® PTC Thermistor Card MCB 112 monitors the temperature in the motor windings with an ATEX-approved motor overload protection device. If there is a critical temperature level or a malfunction, switch off the motor. If the drive is equipped with 3 or 6 PTC thermistors in series according to DIN VDE V 0898-1-401: 2020-03, the MCB 112 offers ATEX-approved monitoring of the motor temperature. Alternatively, an external ATEX-approved PTC protection device can be used.

**1.5.4 ATEX ETR Thermal Monitoring**

**NOTICE**

The ATEX ETR thermal monitoring function only applies to Ex eb and Ex ec motors. There is no need of ATEX ETR thermal monitoring for Ex db motors.

FC 302 with firmware version V6.3x or higher, FC 102 with firmware version V4.40 or higher, and FC 202 with firmware version V2.63 or higher are equipped with an ATEX ETR thermal monitoring function for operation of Ex eb and Ex ec motors according to EN 60079-7. Combined with an ATEX-approved PTC monitoring device like the MCB 112, the installation does not need an individual approval from an approbated organization, so there is no need for a specific matched-pairs approval.

The ETR Thermal Monitoring feature makes it easier to apply Ex eb and Ex ec motors instead of the more expensive, larger, and heavier Ex db motors. The use of Ex eb and Ex ec motors is possible by ensuring that the drive limits the motor current to prevent the motor from heating up.

### 1.5.5 Tripping Function

The VLT® PTC Thermistor Card MCB 112 includes a tripping stage for PTC thermistor sensors with safe potential separation of supply voltage from ground. The tripping function switches off the +24 V DC directly at terminal 37 on the drive.

The PNP logic output terminal X44/10 signals the status in case of failure. The MCB 112 works according to the closed-circuit principle. The device trips in case of short circuit or line interruption.

### 1.5.6 Safe Separation

The PTC thermistor circuit (T1, T2) has a safe separation of low-voltage electric circuits (PELV, see [3.4 Connecting Sensor Circuit Wires](#)).

### 1.5.7 Safe Disconnection Principle

The Safe Torque Off function disables the control voltage of the power semiconductors or the drive output stage. Disabling the control voltage prevents the inverter from generating the voltage required to rotate the motor.

### 1.5.8 Safe Disconnection Principle Diagram

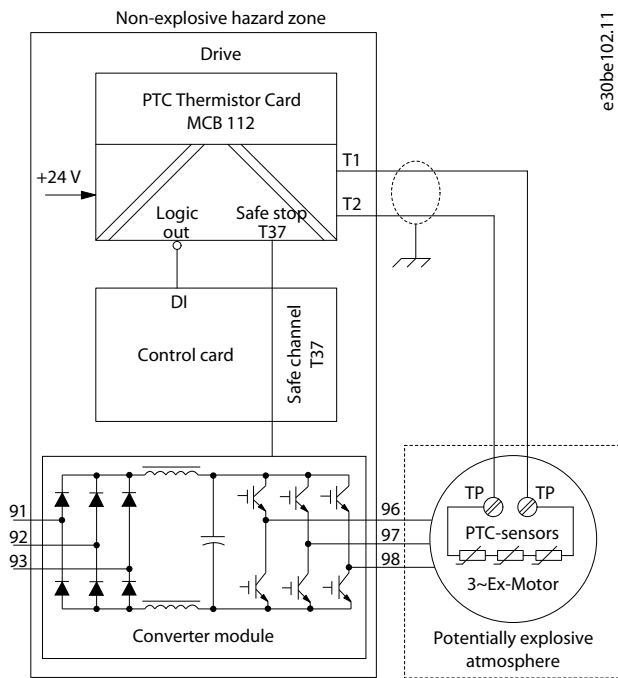

e30be102.11

Illustration 2: Block Diagram of Safe Disconnect with MCB 112



## 1.6 Motor Requirements

### 1.6.1 Motor Limits and Rules

For every certified motor with increased safety, the manufacturer supplies a data list including limits and rules. During planning, installation, commissioning, operation, and service, respect the limits for:

- Minimum switching frequency.
- Maximum current.
- Minimum motor frequency.
- Maximum motor frequency.

Furthermore, respect the following:

- Do not exceed the maximum allowable ratio between drive size and motor size. The typical value is  $I_{VLT,n} \leq 2 \times I_{m,n}$ .
- Consider all voltage drops from the drive to the motor. If the motor is running with lower voltage than listed in the U/f characteristics, current might increase and cause an alarm.
- Multi-motor applications are not allowed. Only connect 1 motor to the drive.

### 1.6.2 Additional Motor Requirements

The Ex eb motor must be approved for operation in hazardous zones (ATEX Zone 1/21, ATEX Zone 2/22) in combination with drives. The motor must be certified for the particular hazardous zone.



The Ex ec motor must be approved for operation in hazardous zones (ATEX Zone 2/22) in combination with drives. The motor must be certified for the particular hazardous zone.

## N O T I C E

The motor can be placed in Zone 1/21 or 2/22 according to motor approval. The drive must always be installed outside of the hazardous zone.

- Only operate explosion-protected 3-phase motors with drives if the motors are built, tested, approved, and labeled separately for this mode.
- When the usage of the motor and its thermal protective device are approved for drive operation, use the VLT® PTC Thermistor Card MCB 112 for each ignition protection system for all motor types. For motors of Ex eb and Ex ec ignition protection, which are OEM-approved for drive operation in Ex-hazardous areas, consider and use the requested limitations in the drive's ATEX ETR thermal monitoring settings.
- The necessary parameters and conditions are on the nameplate and in the documentation of the motor. To prevent prohibited temperatures, the motors are equipped as standard with thermal winding protection, which has to be evaluated by a suitable device like MCB 112. The motors must not be operated as a group drive.

### 1.6.3 Approvals and Certifications

	 Certification number: PTB 14 ATEX 3009
---	---

Certificates and declarations of conformity are available. Contact a local Danfoss partner.

## 1.7 Abbreviations and Conventions

### 1.7.1 Abbreviations

Abbreviation	Description
ETR	Electronic thermal relay
LCP	Local control panel

Abbreviation	Description
NC	Not connected
PNP	Positive negative positive (transistor)
TNF	Nominal response temperature

Abbreviation	Reference	Description
ATEX	ATEX Directive 2014/34/EU	ATmosphere EXplosibles.
HFT	EN IEC 61508	Hardware fault tolerance: HFT=n means that n+1 faults could cause a loss of the safety function.
PDS/SR	EN IEC 61800-5-2	Power drive system (safety-related).
PFD	EN IEC 61508	Average probability of failure on demand, value used for low-demand operation.
SFF	EN IEC 61508	Safe failure fraction [%]; percentage of safe failures and dangerous detected failures of a safety function or a subsystem related to all failures.
SIL	EN IEC 61508, EN IEC 62061	Safety integrity level.
STO	EN IEC 61800-5-2	Safe Torque Off
SRECS	EN IEC 62061	Safety-related electrical control system.

## 1.7.2 Conventions

- Numbered lists indicate procedures.
- Bulleted and dashed lists indicate listings of other information where the order of the information is not relevant.
- Bolded text indicates highlighting and section headings.
- Italicized text indicates the following:
  - Cross-reference.
  - Link.
  - Footnote.
  - Parameter name.
  - Parameter option.
  - Parameter group name.
- All dimensions in drawings are in metric values (imperial values in brackets).
- An asterisk (\*) indicates the default setting of a parameter.

## 2 Safety

### 2.1 Safety Symbols

The following symbols are used in this manual:

<b>⚠ D A N G E R ⚠</b>
Indicates a hazardous situation which, if not avoided, will result in death or serious injury.
<b>⚠ W A R N I N G ⚠</b>
Indicates a hazardous situation which, if not avoided, could result in death or serious injury.
<b>⚠ C A U T I O N ⚠</b>
Indicates a hazardous situation which, if not avoided, could result in minor or moderate injury.
<b>N O T I C E</b>
Indicates a property damage message.

### 2.2 Qualified Personnel

The products must only be assembled, installed, programmed, commissioned, maintained, and decommissioned by persons with proven skills. Persons with proven skills:

- Are qualified electrical engineers, or persons who have received training from qualified electrical engineers and are suitably experienced to operate devices, systems, plant, and machinery in accordance with the general standards and guidelines for safety technology.
- Are familiar with the basic regulations concerning health and safety/accident prevention.
- Have read and understood the safety guidelines given in this manual and also the instructions given in the operating guide of the drive.
- Have good knowledge of the generic and specialist standards applicable to the specific application.

### 2.3 Responsibilities of Users of Safety-related Power Drive Systems PDS (SR)

Users of safety-related Power Drive Systems (PDS (SR)) are responsible for:

- Carry out a hazard and risk analysis of the application according to EN ISO 12100.
- Ensure that the qualified personnel have experience with working in ATEX areas according to Directive 99/92/EC (also known as the ATEX Workplace Directive).
- Identify safety functions required, and allocate SIL or PLr to each of the functions.
- Identify other subsystems and validate the signals and commands from those subsystems.
- Design appropriate safety-related control systems (hardware, software, parameterization, and more).

### 2.4 Protective Measures

Qualified and skilled personnel must be available for installing and commissioning the safety engineering systems.

#### Procedure

1. Install the drive in an IP54 cabinet as per IEC 60529, or in an equivalent environment. In special applications, a higher IP rating may be necessary.
2. Ensure short-circuit protection of the cable between terminal 37 and the external safety device according to ISO 13849-2 table D.4.
3. Optional step: Install additional measures (for example, a safety holding brake) if external forces influence the motor axis (for example, suspended loads).

## 2.5 Safety Precautions

### ⚠ WARNING ⚠

#### EXPLOSION HAZARD

Using the VLT® PTC Thermistor Card MCB 112 in areas with explosive gas and/or dust atmospheres may lead to death, personal injury, or property damage. To avoid the risk, adhere to the following:

- Always provide the MCB 112 with a pressurized enclosure according to EN 60079-1 (Explosive atmospheres - Part 1: Equipment protection by flameproof enclosures "d").
- Observe national safety rules and regulations for prevention of accidents, as well as the European Standard EN 60079-14 (Explosive atmospheres - Part 14: Electrical installations design, selection, and erection).
- Only qualified personnel is allowed to install, connect, and commission the MCB 112.
- Ensure that the motor thermal protection switches off the motor directly, via the Safe Torque Off (STO) function, and/or by using the ATEX ETR thermal monitoring function.

### ⚠ WARNING ⚠

#### FIRE HAZARD

Using the VLT® PTC Thermistor Card MCB 112 in areas with combustible dust may lead to death, personal injury, or property damage. To avoid the risk, adhere to the following:

- Always provide the MCB 112 with a dust-proof enclosure according to IEC 60529.
- Observe national safety rules and regulations for prevention of accidents, as well as the European Standard EN 60079-14 (Explosive atmospheres - Part 14: Electrical installations, design, selection, and erection).
- Only qualified personnel is allowed to install, connect, and commission the MCB 112.

For more information on qualified personnel, see [2.2 Qualified Personnel](#).

### ⚠ WARNING ⚠

#### UNINTENDED START

When the drive is connected to AC mains, DC supply, or load sharing, the motor may start at any time, causing risk of death, serious injury, and equipment or property damage. The motor may start by activation of an external switch, a fieldbus command, an input reference signal from the LCP or LOP, via remote operation using MCT 10 setup software, after a cleared fault condition, or after the motor and motor thermistors have cooled down.

- Press [Off] on the LCP before programming parameters.
- Disconnect the drive from the mains whenever personal safety considerations make it necessary to avoid unintended motor start.
- Check that the drive, motor, and any driven equipment are in operational readiness.

### ⚠ CAUTION ⚠

#### RISK OF INJURY AND EQUIPMENT DAMAGE

Read and observe this operating guide and the safety warnings before installing the VLT® PTC Thermistor Card MCB 112. Not adhering to the instructions and warnings in this manual may lead to personal injury, property and equipment damage.

## 3 Installation

### 3.1 Safety Instructions

See chapter *Safety* for general safety instructions. Also, always observe the relevant drive operating guide and the instructions provided by the motor manufacturer.

### 3.2 Installing the VLT® PTC Thermistor Card MCB 112

#### ⚠ WARNING ⚠

##### DISCHARGE TIME

The drive contains DC-link capacitors, which can remain charged even when the drive is not powered. High voltage can be present even when the warning indicator lights are off.

Failure to wait the specified time after power has been removed before performing service or repair work could result in death or serious injury.

- Stop the motor.
- Disconnect AC mains, permanent magnet type motors, and remote DC-link supplies, including battery back-ups, UPS, and DC-link connections to other drives.
- Wait for the capacitors to discharge fully before performing any service or repair work. The discharge time is printed on the type label of the drive and also specified in the **Discharge time** tables in the FC 102/202/302 Operating Guides.
- Use a measuring device to make sure that there is no voltage, before opening the drive or performing any work on the cables.

#### ⚠ CAUTION ⚠

Place the drive with VLT® PTC Thermistor Card MCB 112 (including the connection between output safe stop T37 output (X44/12) on MCB 112 and terminal 37 input on the control card) in an IP54 enclosure as per IEC 60529.

#### ⚠ CAUTION ⚠

##### RISK OF OVERVOLTAGE

Long cables (voltage peaks) or increased mains voltage may lead to overvoltage at the motor terminals and damage the equipment.

- Install a sine-wave filter.

#### NOTICE

For motor connection, AC mains connection, and control wiring, follow the instructions for safe installation in the drive operating guide and in the VLT® Frequency Converter - Safe Torque Off Operating Guide.

#### Procedure

1. Disconnect power to the drive.
2. Remove the LCP, the terminal cover, and the LCP frame from the drive.

- Fit the MCB 112 in slot B, see [Illustration 3](#).

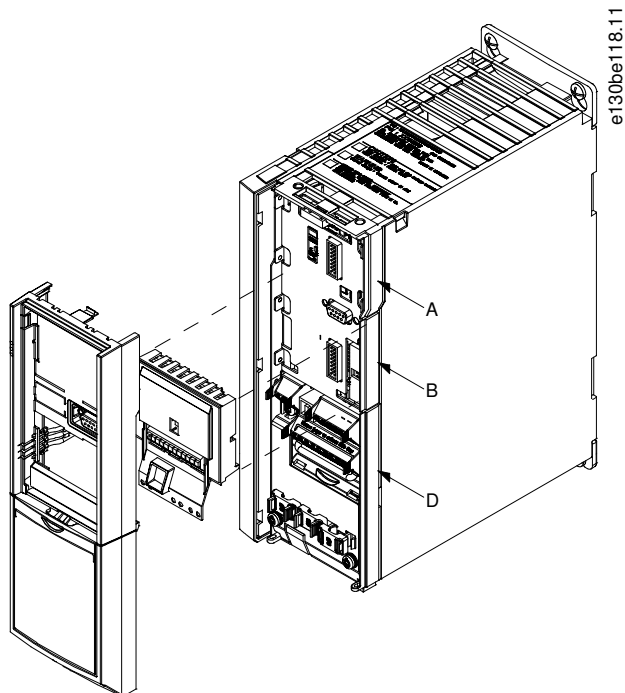

Illustration 3: LCP Frame and Terminal Cover Removal

### 3.3 Sensor Circuit Wire Requirements

#### ⚠ WARNING ⚠

**NO SAFE FUNCTION**

Using sensor wires with a resistance  $>20 \Omega$  causes the safe function not to work.

- To ensure a properly working safe function, only use sensor circuit wires with a resistance  $<20 \Omega$ .

Wire cross-section [mm <sup>2</sup> (AWG)]	Wire length [m (ft)]
1.5 (16)	2x800 (2x2625)
1 (17)	2x500 (2x1640)
0.75 (18)	2x300 (2x984)
0.5 (20)	2x250 (2x820)

### 3.4 Connecting Sensor Circuit Wires

#### NOTICE

The connections are not pre-wired from factory.

#### NOTICE

Route the sensor circuit wires as separate control wires. It is not allowed to use wires from the supply cable or any other mains cables. Use shielded control wires. See [3.5 Maximum Current on MCB 112](#) for correct wiring.

Connect the sensor circuit wires for the VLT® PTC Thermistor Card MCB 112 as follows:

#### Procedure

1. Select the appropriate sensor wires.
2. Route the sensor wires.
3. Remove the shielding in the area of the shielding clamps.

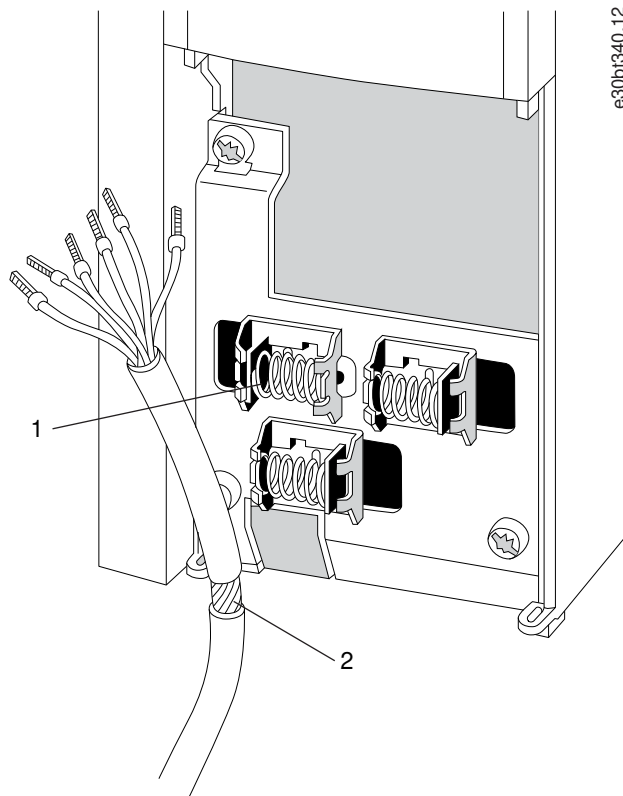

Illustration 4: Connecting Shielded Wire

- |   |                   |
|---|-------------------|
| 1 | Shielding clamps  |
| 2 | Removed shielding |

4. Measure the sensor resistance.
5. Connect the sensor circuit wires to X44/T1 and T2, see [3.4 Connecting Sensor Circuit Wires](#).

#### NOTICE

Only check PTCs with measuring voltages of <2.5 V.

- At commissioning and after modification of the plant, check the sensor resistance with a suitable measuring instrument. If the resistance between terminals 1 and 2 is  $<50 \Omega$ , examine the sensor circuit for a short circuit.

### 3.5 Maximum Current on MCB 112

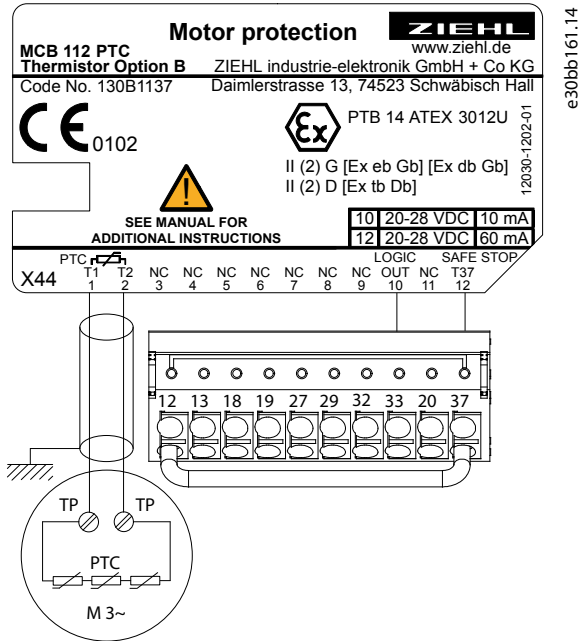

Illustration 5: Wiring Diagram

T10	10 mA
T12	60 mA

Terminal 12	24 V DC supply voltage
Terminal 13	24 V DC supply voltage
T37 (X44/12)	Output terminal on the VLT® PTC Thermistor Card MCB 112 option.
Terminal 37	Input terminal on the control card.
X44/10	Logic output signals the status in case of failure.

### 3.6 Wiring of STO

#### Procedure

- Remove the jumper wire between control terminals 37 and 12, or 13. Cutting or breaking the jumper is not sufficient to avoid short circuiting.



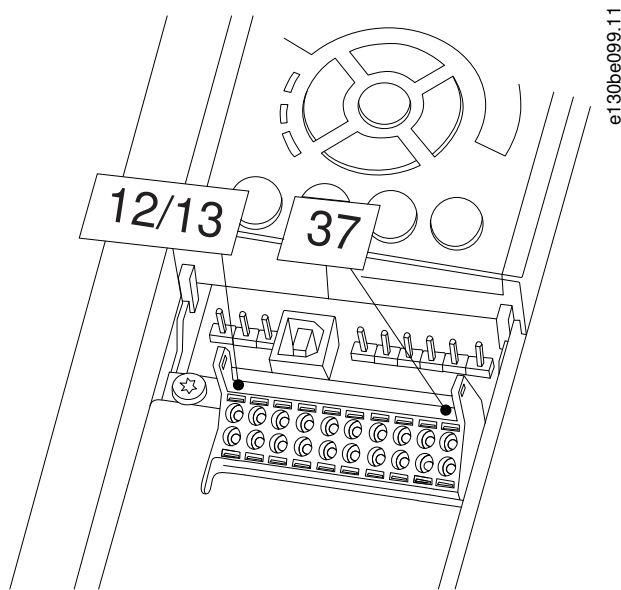

2. Connect X44/12 on the option to terminal 37 on the drive.
3. Connect terminal X44/10 to a digital input of the drive. For reference when programming, note the number of selected digital input.

### 3.7 Assembly

#### Procedure

1. Remove the knock-out in the extended LCP frame, so that the option fits under the extended LCP frame.
2. Fit the extended LCP frame and terminal cover.
3. Fit the LCP or blind cover in the extended LCP frame.
4. To indicate that the ATEX module is integrated, apply the delivered sticker to the front of the drive, see [1.5.1.1 Markings of the Drive](#).
5. Connect power to the drive.
6. Perform risk assessment and a commissioning test according to EN ISO 12100.

## 4 Commissioning

### 4.1 Commissioning the Drive

#### Procedure

1. For commissioning the STO, follow the instructions in the section *Commissioning* of the VLT® Frequency Converters Safe Torque Off Operating Guide.
  - a. Read and understand the safety instructions.
  - b. Activate the STO.
  - c. Set the parameters (automatic or manual restart).
  - d. Perform STO commissioning test.
  - e. Ensure system configuration security.
2. Test the correct function of the MCB 112 by simulation of the sensor resistance at terminals T1 and T2. This test must also be done at maintenance services.
  - a. Perform a short-circuit test: Resistance  $20\ \Omega$  in parallel to sensor terminals T1 and T2.
  - b. Perform a line interruption test: Disconnect sensor line at terminal T1 or T2.
  - c. Perform a temperature test: Increase resistance  $50\text{--}1500\ \Omega$  to  $4000\ \Omega$ . The tripping function is stated in the LCP and can be reset manually when the failure is removed. The output states of X44/12 and X44/10 shall be as shown in the illustration in [4.2.2 Monitoring Sensor Resistance](#). Pay attention to the ambient conditions, see chapter *Specifications*.

### 4.2 Operation and Maintenance

#### 4.2.1 Testing

The safety function must be tested with regular intervals.

Test once per year, or within the maintenance cycle of the plant.

For recurring examinations of electrical systems in hazardous areas, the inspection period must be kept within 3 years. The safety test recognizes 1 fault (1oo1 - 1 out of 1). One fault between safety tests can cause loss of protection.

#### 4.2.2 Monitoring Sensor Resistance

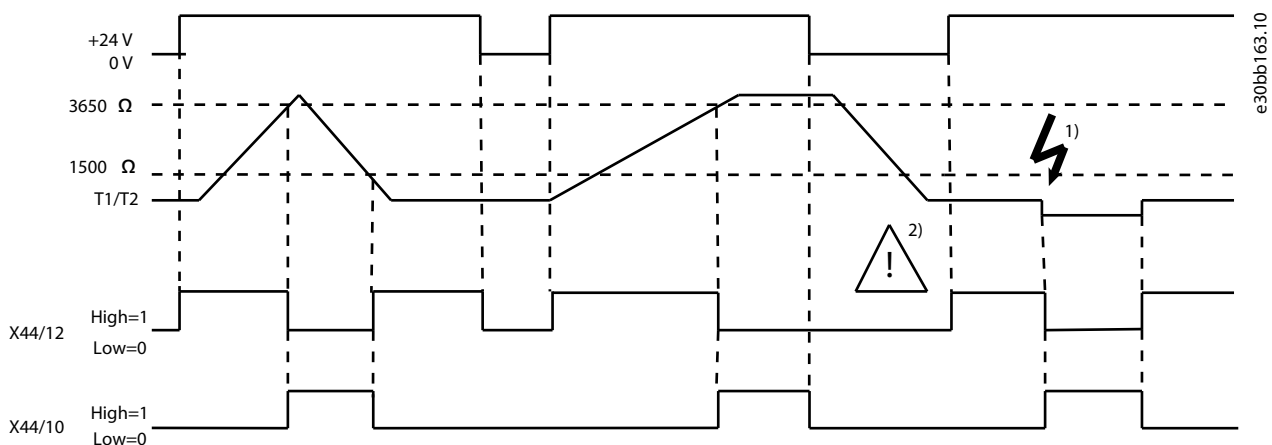

Illustration 6: Monitoring of Sensor Resistance

- |   |  |
|---|--|
| 1 | Short circuit  |
| 2 | Tripping is not saved and is not protected against 0 voltage |

A current continuously monitors the resistance of the sensors. In cold state, the resistance is  $<250\ \Omega$  per sensor (sensor circuit  $<1.5\ \text{k}\Omega$ ). The output to terminal X44/12 is high=1. The resistance of the sensor rises rapidly at nominal response temperature TNF. At a resistance of  $3\text{--}4\ \text{k}\Omega$ , output to terminal X44/12 changes to low=0. The devices also switch off if the sensor wire short-circuits ( $<20\ \Omega$ , or if the sensor or wire is interrupted). It switches back on automatically when the temperature has decreased by approximately  $5\ ^\circ\text{C}$  ( $41\ ^\circ\text{F}$ ).

Depending on the number of sensors, the following tripping and release temperatures are achieved with respect to TNF (nominal response temperature of the sensors).

	Trip temperatures	Release temperatures
3 sensors in series	TNF+5 K	TNF-5 K
6 sensors in series	TNF	TNF-20 K

### 4.2.3 Thermal Limitation Curve (Ex eb and Ex ec Motors Only)

**⚠ WARNING ⚠**

**EXPLOSION DANGER**

- Always use the thermal limitation curve in combination with Ex eb and Ex ec motors. See [Illustration 8](#).

The output current/motor speed is permanently monitored and limited depending on the characteristic given by the motor manufacturer on the motor nameplate data and data sheets.

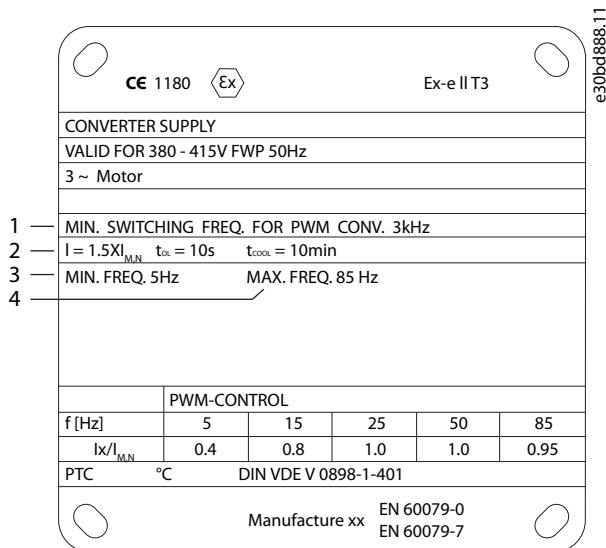

Illustration 7: Motor Nameplate Showing Drive Requirements

1	Minimum switching frequency	3	Minimum motor frequency
2	Maximum current	4	Maximum motor frequency

#### Procedure

- Program the characteristic values as frequency/current pairs in *parameters 1-98 ATEX ETR interpol. points freq.* and *1-99 ATEX ETR interpol points current.*

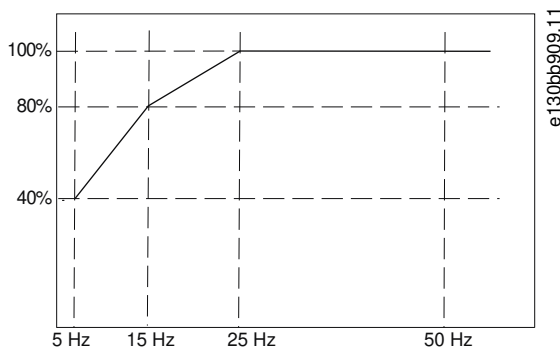

Illustration 8: Example of ATEX ETR Thermal Limitation Curve

Parameter 1-98	Parameter 1-99
[0]=5 Hz	[0]=40%
[1]=15 Hz	[1]=80%
[2]=25 Hz	[2]=100%
[3]=50 Hz	[3]=100%

- Use the 4 current points [A] from the motor nameplate.
- Calculate the values as a percentage of nominal motor current and enter it into the array.

$$\left( \frac{I_x \times 100}{I_{m,n}} (\%) \right)$$

- Program all frequency/current limit points from the motor nameplate or motor data sheet.
- Enter frequency settings for *parameter 1-98 ATEX ETR interpol. points freq.* in Hz, not RPM.

### 4.3 Parameter Set-up

#### 4.3.1 Alarm Handling

## N O T I C E

Ensure that the digital input set to [80] PTC Card 1 is not also connected as a thermistor resource (motor overload protection) in *parameter 1-93 Thermistor Resource*.

Configure the digital input in *parameter group 5-1\* Digital Inputs*.

Digital input function	Select	Terminal
No operation	[0]	All terminals 32, 33
Reset	[1]	All
...		
PTC Card 1	[80]	All
...		

All digital inputs can be set to [80] PTC Card 1. However, only 1 digital input can have this selection.

### 4.4 Parameter Set-up for Ex eb and Ex ec Motors

## N O T I C E

Do not use the ATEX ETR Monitor function with an Ex db motor by setting *Parameter 1-90 Motor Thermal Protection* to a different value than [20] ATEX ETR. This automatically disables the ATEX ETR specific parameters from *parameter 1-94 ATEX ETR cur.lim. speed reduction* to *parameter 1-99 ATEX ETR interpol points current*.

#### 4.4.1 Overview of Ex eb and Ex ec Specific Parameters

Parameter	Setting
<i>Parameter 1-90 Motor Thermal Protection</i>	[20] ATEX ETR
<i>Parameter 1-94 ATEX ETR cur.lim. speed reduction</i>	20%
<i>Parameter 1-98 ATEX ETR interpol. points freq.</i>	Motor nameplate

Parameter	Setting
Parameter 1-99 ATEX ETR interpol points current	Motor nameplate
Parameter 1-23 Motor Frequency	Motor nameplate
Parameter 4-19 Max Output Frequency	Motor nameplate, possible reduced for long motor cables, sine-wave filter, or reduced supply voltage.
Parameter 4-18 Current Limit	Forced to 150% by parameter 1-90 Motor Thermal Protection [20] ATEX ETR.
Parameter 5-15 Terminal 33 Digital Input	[80] PTC Card 1
Parameter 5-19 Terminal 37 Safe Stop	[4] PTC 1 Alarm
Parameter 14-01 Switching Frequency	Check that the default value fulfills the requirement from the motor nameplate. If not, use a sine-wave filter.
Parameter 14-26 Trip Delay at Inverter Fault	0

#### 4.4.2 Activate the ATEX ETR Monitor Function

##### Procedure

1. Set parameter 1-90 Motor Thermal Protection to [20] ATEX ETR.

➔ This activation of the ATEX ETR monitor function enables parameter 1-94 ATEX ETR cur.lim. speed reduction, parameter 1-98 ATEX ETR interpol. points freq., and parameter 1-99 ATEX ETR interpol points current. Furthermore, it limits parameter 4-18 Current Limit to 150%.

#### 4.4.3 Maximum Current Limit

Operation above the thermal characteristic curve is allowed for a limited period of 60 s.

The actual thermal overload is based on the ETR function selected in parameter 1-90 Motor Thermal Protection and is shown in parameter 16-18 Motor Thermal.

Running above the characteristic curve for more than 50 s issues warning 163, ATEX ETR cur.lim.warning. Configure the reaction for operating in Ex eb and Ex ec current limits in parameter 1-94 ATEX ETR cur.lim. speed reduction.

- 0%: The drive does not change anything besides issuing warning 163, ATEX ETR cur.lim.warning.
- >0%: The drive issues warning 163, ATEX ETR cur.lim.warning and reduces motor speed following ramp 2 (parameter group 3-5\* Ramp 2).

##### Example

- Actual reference = 200 RPM
- Parameter 1-94 ATEX ETR cur.lim. speed reduction = 20%
- Resulting reference = 160 RPM

Operating above the characteristic curve for more than 60 s within a period of 600 s issues alarm 164, ATEX ETR cur.lim., and the drive trips.

Operation above 150% nominal motor current trips the drive after 1 s with alarm 164, ATEX ETR cur.lim.

Operation above 180% nominal motor current immediately trips the drive with alarm 164, ATEX ETR cur.lim.

After the 1<sup>st</sup> power-up, the overload counter starts at a value that prevents resetting the thermal load value by power cycling. After start-up, the overload warning is suppressed until the motor current exceeds the rated current for the first time.

#### 4.4.4 Minimum Motor Frequency

The operation below the minimum frequency in parameter 1-98 ATEX ETR interpol. points freq. is allowed for a limited time only.

Running below the minimum frequency for more than 50 s issues warning 165, ATEX ETR freq.lim.warning.

Operation below the minimum frequency for more than 60 s within a period of 600 s issues alarm 166, ATEX ETR freq.lim.alarm. The drive trips.

#### 4.4.5 Maximum Motor Frequency

Do not exceed the maximum allowable output frequency. The motor data sheet or nameplate shows the maximum allowed value.

### N O T I C E

This value can be reduced for long motor cables, sine-wave filter, or reduced supply voltage.

$$f_{\max} = \frac{U_n - U_{\text{loss}}}{U_n} \times f_n$$

Use the result from the equation as the value set in *parameter 4-19 Max Output Frequency*.

#### Example

Nominal voltage = 480 V

Nominal frequency = 50 Hz

Voltage loss due to supply voltage of 450 V = 30 V

Resulting maximum frequency = 47 Hz

#### 4.4.6 Minimum Switching Frequency

### N O T I C E

It is mandatory to compare the minimum switching frequency requirement of the motor to the minimum switching frequency of the drive, which is the default value in *parameter 14-01 Switching Frequency*. If the drive does not meet this requirement, use a sine-wave filter.

Thermal motor losses increase with the lower switching frequencies. Ensure that the drive switching frequency does not drop below the value stated by the motor manufacturer.

#### 4.4.7 Disable Protection Mode

In protection mode, the drive derates the switching frequency below the default in *parameter 14-01 Switching Frequency*. For example, if the default value is 3 kHz, it can derate down to 2.5 kHz, depending on EEPROM.

#### Therefore:

1. Disable protection mode in *parameter 14-26 Trip Delay at Inverter Fault*.  
More information about derating can be found in the section *Derating* in the drive-specific design guide.

#### 4.4.8 Safe Torque Off Functionality

The desired Safe Torque Off functionality is specified in *parameter 5-19 Terminal 37 Safe Stop*. When a VLT® PTC Thermistor Card MCB 112 is mounted, select 1 of the PTC options to get the full benefit from the alarm handling. Options [4] *PTC 1 Alarm* and [5] *PTC 1 Warning* are relevant when the MCB 112 is the only interrupt device using STO. Options [6] *PTC 1 & Relay A* to [9] *PTC 1 & Relay W/A* are relevant when other safety sensors are also connected to STO.

- Alarm: The drive coasts. Reset the alarm manually (via bus, digital I/O, or by pressing [Reset]). Auto reset does not apply here. For more details, see [4] *PTC 1 Alarm* in *parameter 5-19 Terminal 37 Safe Stop*.
- Warning: The drive coasts, but resumes operation when STO and the DI from X44/10 are disabled. For more details, see [5] *PTC 1 Warning* in *parameter 5-19 Terminal 37 Safe Stop*.

Configuring a digital input in *parameter group 5-1\* Digital Inputs* makes it possible to give a warning/alarm that specifies what triggered the Safe Torque Off.

### N O T I C E

When selecting a warning instead of an alarm, automatic restart is enabled. See the section *Parameter Settings for STO* used with VLT® PTC Thermistor Card MCB 112 in the VLT® Frequency Converters - Safe Torque Off Operating Guide.

## 4.4.9 Functions, Alarms, and Warnings

Table 2: Overview of Functions, Alarms, and Warnings

Function	Number	PTC	Relay	Description
No function	[0]	–	–	No function.
Safe stop alarm	[1]*	–	Safe stop [A68] ( <sup>1</sup> )	Coasts the drive when Safe Torque Off is activated. Manual reset from LCP, digital input, or fieldbus.
Safe stop warning	[3]	–	Safe stop [W68]W = warning	Coasts the drive when Safe Torque Off is activated (terminal 37 off). When Safe Torque Off circuit is re-established, the drive continues without manual reset.
PTC 1 alarm	[4]	PTC 1 safe stop [A71]	–	Coasts the drive when Safe Torque Off is activated. Manual reset from LCP, digital input, or fieldbus.
PTC 1 Warning	[5]	PTC 1 safe stop [W1]	–	Coasts the drive when Safe Torque Off is activated (terminal 37 off). When Safe Torque Off circuit is re-established, the drive continues without manual reset, unless a digital input set to [80] PTC Card 1 is still enabled.
PTC 1 & Relay A	[6]	PTC 1 safe stop [A71]	Safe stop [A68]	This option is used when the PTC option gates with a stop button through a safety relay to terminal 37. Coasts the drive when Safe Torque Off is activated. Manual reset from LCP, digital input, or fieldbus.
PTC 1 & Relay W	[7]	PTC 1 safe stop [W71]	Safe stop [W68]	This option is used when the PTC option gates with a stop button through a safety relay to terminal 37. Coasts the drive when Safe Torque Off is activated (terminal 37 off). When Safe Torque Off circuit is re-established, the drive continues without manual reset, unless a digital input set to [80] PTC Card 1 is still enabled.
PTC 1 & Relay	[8]	PTC 1 safe stop [A71]	Safe stop [W68]	This option makes it possible to use a combination of alarm and warning.
PTC 1 & Relay W/A	[9]	PTC 1 safe stop [W71]	Safe stop [A68]	This option makes it possible to use a combination of alarm and warning.
A dangerous failure related to Safe Torque Off issues <i>alarm 72, Dangerous failure</i> , see <a href="#">6.2.2 Alarm/Warning Code List</a> .				

<sup>1</sup> A = alarm, W = warning. For further information, see the section *Alarms and Warnings* in the drive-specific operating guide or design guide.

## 5 Application Examples

### 5.1 Setting up the Option for Standard Use

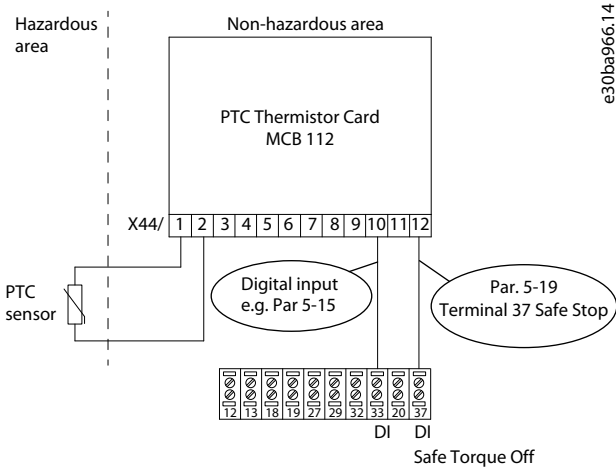

Illustration 9: Standard use of VLT® PTC Thermistor Card MCB 112

Table 3: Programming Example 1

Option number	Option name	Description
<i>Parameter 5-19 Terminal 37 Safe Stop</i>		
[4]	PTC 1 alarm	If the motor temperature is too high or if a PTC failure occurs, the MCB 112 activates the STO. Terminal 37 goes low (active), and digital input 33 goes high (active). This parameter decides the consequence of the Safe Torque Off (STO). With this selection, the drives coasts and the LCP shows <i>alarm 71, PTC 1 safe stop</i> . Reset the drive manually from the LCP, digital input, or fieldbus when the conditions of the PTC are acceptable again (motor temperature has dropped).
<i>Parameter 5-15 Terminal 33 Digital Input</i>		
[80]	PTC card 1	Connects the digital input of terminal 33 in the drive to the MCB 112, which enables the MCB 112 to indicate when the STO has been activated from here.

Alternatively, *Parameter 5-19 Terminal 37 Safe Stop* could be set to [5] *PTC 1 Warning*, which means an automatic restart when the conditions of the PTC circuit have returned to acceptable. The selection depends on customer demands.



### 5.2 Combination with Other Components using STO

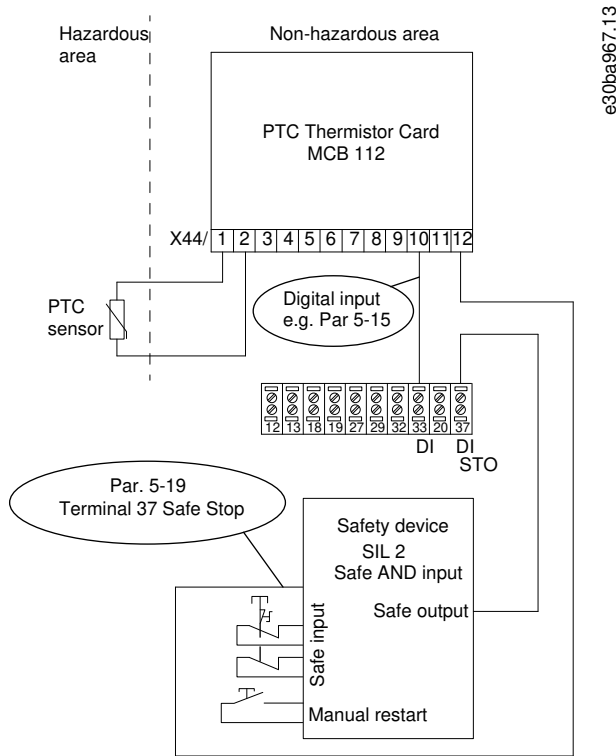

Illustration 10: More Safety Devices in Combination with STO and VLT® PTC Thermistor Card MCB 112

Table 4: Programming Example 2

Option number	Option name	Description
<i>Parameter 5-19 Terminal 37 Safe Stop</i>		
[6]	PTC 1 & Relay alarm	If the motor temperature is too high, or if a PTC failure occurs, the MCB 112 activates the STO of the drive. Terminal 37 goes low (active), and digital input 33 goes high (active). This parameter decides the consequence of the Safe Torque Off (STO). With this selection, the drive coasts and the LCP shows <i>alarm 71, PTC 1 safe stop</i> . Reset the drive manually from LCP, digital input, or fieldbus when the conditions of the PTC are acceptable again (motor temperature has dropped). An emergency stop can also activate STO. Terminal 37 goes low (active), but MCB 112 X44/10 does not trigger digital input 33 as the MCB 112 did not have to activate the STO. Therefore, digital input 33 remains high (inactive).
<i>Parameter 5-15 Terminal 33 Digital Input</i>		
[80]	PTC card 1	Connects the digital input of terminal 33 to the MCB 112, which enables the MCB 112 to indicate when STO has been activated from here.

Alternatively, *parameter 5-19 Terminal 37 Safe Stop* could be set to [7] *PTC 1 & relay warning*. Selecting this option causes an automatic restart when the conditions of the PTC circuit and/or emergency stop circuit have returned to normal. The selection depends on customer demands. Also, the setting of *parameter 5-19 Terminal 37 Safe Stop* could be [8] *PTC 1 & relay A/W* or [9] *PTC 1 & relay W/A*, which is a combination of alarms and warnings. The selection depends on customer demands.

## NOTICE

Selections [4] *PTC 1 alarm* to [9] *PTC 1 & relay W/A* in *parameter 5-19 Terminal 37 Safe Stop* are only visible if the MCB 112 is plugged into the B-option slot.

**N O T I C E**

Take care that the digital input set to *[80] PTC card 1* is not also configured as thermistor resource (motor overload protection) in *parameter 1-93 Thermistor Resource*.

## 6 Maintenance and Troubleshooting

### 6.1 Maintenance

The devices are maintenance-free. Only the manufacturer ([www.ZIEHL.de](http://www.ZIEHL.de)) is allowed to perform repair work. Observe EN 60079-17 Explosive atmospheres - Part 17: Electrical installations, inspection, and maintenance.

### 6.2 Troubleshooting

#### 6.2.1 Test the Sensor Circuit and Relay Function

##### Procedure

1. Test the resistance in the sensor circuit.  
The resistance must be  $50\ \Omega < R < 1500\ \Omega$ . The terminal voltage must be  $< 2.5\ V$  with the resistors attached.
2. Test the relay function.  
If terminal T1-T2 is open, the voltage level of terminal X44/12 changes to low=0. The terminal voltage must be approximately 9 V.

#### 6.2.2 Alarm/Warning Code List

Table 5: Alarms and Warnings Directly Related to STO

Number	Description	Warning	Alarm/trip <sup>(1)</sup>	Alarm/trip lock <sup>(1)</sup>	Parameter reference
68	Safe stop activated	X	X		Parameter 5-19 Terminal 37 Safe Stop
71	PTC 1 safe stop	x	x		Parameter 5-19 Terminal 37 Safe Stop
72	Dangerous failure			X	Parameter 5-19 Terminal 37 Safe Stop

<sup>1</sup> Cannot be auto reset via *parameter 14-20 Reset Mode*.

#### 6.2.3 Description of Alarm Word, Warning Word, and Extended Status Word

Table 6: Bit Descriptions

Bit	Hex	Dec	Alarm word	Alarm word2	Warning word	Warning word2
30	40000000	1073741824	Safe stop [A68]	PTC 1 safe stop [A71]	Safe stop [W68]	PTC 1 safe stop [W71]
31	80000000	2147483648		Dangerous failure [A72]		

#### 6.2.4 Alarm 68, Safe Stop

STO has been activated. To resume normal operation, apply 24 V DC to terminal 37, then send a reset signal (via bus, digital I/O, or by pressing [Reset]).

#### 6.2.5 Warning 68, Safe Stop

STO has been activated. To resume normal operation, disable STO.

### ⚠ WARNING ⚠

#### AUTOMATIC RESTART

When the conditions of the PTC circuit and/or emergency stop circuit have returned to normal, the motor restarts automatically.

#### 6.2.6 Alarm 71, PTC 1 Safe Stop

STO has been activated from the VLT® PTC Thermistor Card MCB 112 (motor too warm). Normal operation can be resumed when:

- The MCB 112 applies 24 V DC to terminal 37 again (when the motor temperature reaches an acceptable level), and
- The digital input from the MCB 112 is deactivated.

Send a reset signal via bus, digital I/O, or by pressing [Reset].

### 6.2.7 Warning 71, PTC 1 Safe Stop

STO has been activated from VLT® PTC Thermistor Card MCB 112 (motor too warm). Normal operation can be resumed when:

- The MCB 112 applies 24 V DC to terminal 37 again (when the motor temperature reaches an acceptable level), and
- The digital input from the MCB 112 is deactivated.

#### ⚠ WARNING ⚠

##### AUTOMATIC RESTART

When the conditions of the PTC circuit and/or emergency stop circuit have returned to normal, the motor restarts automatically.

### 6.2.8 Alarm 72, Dangerous Failure

STO with trip lock. If the combination of STO commands is unexpected, the dangerous failure-alarm is issued. This situation occurs if the VLT® PTC Thermistor Card MCB 112 enables X44/10 without STO being enabled. Furthermore, if the MCB 112 is the only device using STO (specified in [4] PTC 1 alarm or [5] PTC 1 warning in parameter 5-19 Terminal 37 Safe Stop), an unexpected combination activates the STO without activating the X44/10. [Table 7](#) summarizes the unexpected combinations that trigger this alarm.

#### N O T I C E

If X44/10 is activated in [2] Safe stop alarm or [3] Safe stop warning, this signal is ignored. However, the MCB 112 is still able to activate STO.

#### N O T I C E

For correct and safe use of the STO function, follow the related information and instructions in the VLT® Frequency Converter - Safe Torque Off Operating Guide.

#### Example

[5] PTC 1 Warning is selected in parameter 5-19 Terminal 37 Safe Stop, and X44/10 is not activated, but STO is. This is an unexpected selection. [5] PTC 1 Warning in parameter 5-19 Terminal 37 Safe Stop specifies that STO is only triggered from MCB 112.

### 6.2.9 Unexpected Combinations

Table 7: Unexpected Combinations Triggering Alarm 72 Dangerous Failure

Function	Number	X44/10 (DI)	STO terminal 37
PTC 1 Alarm	[4]	+ <sup>(1)</sup>	- <sup>(2)</sup>
		-	+
PTC 1 Warning	[5]	+	-
		-	+
PTC 1 & Relay A	[6]	+	-
PTC 1 & Relay W	[7]	+	-
PTC 1 & Relay A/W	[8]	+	-
PTC 1 & Relay W/A	[9]	+	-

<sup>1</sup> + = Activated

<sup>2</sup> - = Not activated

## 7 Specifications

### 7.1 Mains Supply

Rated supply voltage $U_s$	24 V DC
Tolerance voltage $U_s$	21–28 V DC
Power consumption	<1 W

### 7.2 Control Inputs and Outputs

#### 7.2.1 PTC Thermistor Connection X44/1+X44/2

Standard	DIN VDE V0898-1-401
Numbers	Set with 3 or 6 PTCs in series
Cutout point	3.3 k $\Omega$ ...3.65 k $\Omega$ ...3.85 k $\Omega$
Reclosing point	1.7 k $\Omega$ ...1.8 k $\Omega$ ...1.95 k $\Omega$
Collective resistance cold sensors	$\leq 1.65$ k $\Omega$
Terminal voltage (sensors)	$\leq 2.5$ V at $R \leq 3.65$ k $\Omega$ , $\leq 9$ V at $R = \infty$
Terminal current (sensors)	$\leq 1$ mA
Short circuit	20 $\Omega$ $\leq$ 40 $\Omega$
Power consumption	$\leq 2$ mW

#### 7.2.2 Safe Stop Terminal 37, X44/12

Output	PNP transistor
Logical voltage level	0–24 V DC
Voltage, Low=0	PNP <4 V DC
Voltage, High=1	PNP >20 V DC
Current	60 mA

#### 7.2.3 Logic out, X44/10

Output	PNP transistor
Logical voltage level	0–24 V DC
Voltage, Low=0	PNP <5 V DC
Voltage, High=1	PNP >10 V DC
Current	10 mA

### 7.3 Ambient Conditions

#### 7.3.1 Environment

Rated ambient temperature range, $T_a$	-20 °C (-4 °F) to +55 °C (131 °F)
Relative humidity	5–95%, without condensation
EMC - Immunity Industry Standard	EN 61000-6-2
EMC - Emission Industry Standard	EN 61000-6-4
Vibration resistance	10–1000 Hz 1.1.4 g
Shock resistance	50 g

#### 7.3.2 Testing Conditions

Standards	EN 60947-8, EN 50178
Rated impulse voltage	6000 V

Overvoltage category	III
Contamination level	2
Rated insulation voltage $U_i$	690 V
Safe separation up to $U_i$	500 V

## 7.4 Other Specifications

Form	PA 6
Dimensions (H x W x T) [mm]	82.5 x 69.5 x 29.5
Wire connection, solid wire	1 x 0.5–1.5 mm <sup>2</sup> (AWG 20–16 solid wire)
Insulation strip length	8.5–9.5 mm (0.33–0.37 in)
Protection rating IEC 60529	IP20
Weight	≈50 g (1.7 oz)

## 7.5 Safety Characteristics of the Built-in MCB 112

The safety characteristics include the connection between output safe stop T37 (output X44/12 on VLT® PTC Thermistor Card MCB 112) and terminal 37 input on the control card.

Table 8: Safety Integrity Level SIL (EN 61508)

Operating mode	Hardware architecture	Fault tolerance HFT	Safety integrity level	Subsystem
Low demand mode	1oo1	0	SIL 2	Type A device

Table 9: Safety-related Parameters, Part 1

MCB 112	MTBF	SFF	$\lambda_{SD}$	$\lambda_{SU}$	$\lambda_{DD}$	$\lambda_{DU}$
$T_a=40\text{ °C}$	44 years	96,5%	$2103 \times 10^{-9}/h$	$41.8 \times 10^{-9}/h$	$1.23 \times 10^{-9}/h$	$81.4 \times 10^{-9}/h$

Table 10: Safety-related Parameters, Part 2

MCB 112	Proof test interval	1 year	3 years	5 years	10 years
$T_a=40\text{ °C}$	$PFD_{avg}$	3.37E-04	1.01E-03	1.68E-03	3.37E-03

Observe the proof test interval according to EN 60079-17 for electrical equipment  $\leq 3$  years.

The data of the functional safety stated in [Table 8](#) to [Table 10](#) are valid for an ambient temperature of 40 °C (104 °F). Data for more ambient temperatures can be obtained on request.

## Index

### A

Abbreviations.....	9
Actual reference.....	21
Alarm handling.....	20
Alarm word.....	27
Allowed length.....	14
Ambient conditions.....	29
Approvals.....	9
ATEX certification.....	7
ATEX Directive 2014/34/EU.....	7
ATEX module.....	7, 17
Auto reset.....	22

### B

Block diagram, MCB 112.....	8
-----------------------------	---

### C

Certifications.....	9
Combustible dust.....	12
Conventions.....	10

### D

Dangerous failure.....	23, 28, 28
Derating.....	22
DIN VDE V0898-1-401.....	29

### E

EN 60079-1.....	12
EN 60079-14.....	7, 12, 12
EN 60079-17.....	30
EN 60079-17 Explosive atmospheres.....	27
EN 60079-7.....	8
EN 60947-8.....	6
EN 61000-6-2.....	29
EN 61000-6-4.....	29
EN 61508.....	30
EN ISO 121010.....	17
Environment.....	29
EN 50178.....	29
EN 60947-8.....	29
ETR monitoring function.....	21
Ex eb current limit.....	21
Ex eb motor.....	8, 9, 19
Ex ec current limit.....	21
Ex ec motor.....	8, 9, 19
Explosive dust atmosphere.....	12
Explosive gas atmosphere.....	12
Extended status word.....	27

### F

Foreseeable misuse.....	7
-------------------------	---

### I

IEC 60529.....	11, 12, 13
Intended use.....	6
ISO 13849-2.....	11

### M

Maintenance.....	27
Marking D.....	6
Marking G.....	6
Minimum frequency.....	21
Misuse of product.....	7
See Foreseeable misuse	
Monitoring.....	7
Motor requirement.....	9
Multi-motor applications.....	9

### N

Nameplate.....	9, 19
----------------	-------

### O

Overvoltage.....	13
------------------	----

### P

Protection mode.....	22
----------------------	----

### Q

Qualified personnel.....	6, 11, 12
--------------------------	-----------

### R

Release temperature.....	18
Repair work.....	27
Requirement, drive.....	19
Resulting reference.....	21

### S

Safe separation.....	8
Safe stop T37.....	13
Safe Torque Off.....	8, 23
Safe Torque Off functionality.....	22
Safety function.....	18
Safety integrity level SIL.....	30
Sensor circuit wires.....	15
Separate control wires.....	15
Shielded control wires.....	15
Sticker.....	7
Symbols.....	11

### T

Testing.....	18
Testing conditions.....	29
Thermal limitation curve.....	19
Thermal monitoring function.....	8, 12
Thermal motor protection.....	7
Thermal winding protection.....	9
Tripping function.....	8

### V

Version history.....	6
Voltage drop.....	9

### W

Warning word.....	27
-------------------	----

X	Z
X44/1.....29	Zone 1.....6, 9
X44/10.....8, 17, 22, 29	Zone 2.....6, 9
X44/12.....13, 17, 18, 29, 30	Zone 21.....6, 9
X44/2.....29	Zone 22.....6, 9





**Danfoss A/S**  
Ulsnaes 1  
DK-6300 Graasten  
[vlt-drives.danfoss.com](http://vlt-drives.danfoss.com)

---

Danfoss can accept no responsibility for possible errors in catalogs, brochures, and other printed material. Danfoss reserves the right to alter its products without notice. This also applies to products already on order provided that such alterations can be made without subsequential changes being necessary in specifications already agreed. All trademarks in this material are property of the respective companies. Danfoss and the Danfoss logotype are trademarks of Danfoss A/S. All rights reserved.

---

