

ENGINEERING  
TOMORROW

*Danfoss*

Operating Guide

# VLT® Compressor Drive CDS 803

6–30 kW





## Contents

|          |  |           |
|----------|--|-----------|
| <b>1</b> | <b>Introduction</b>                                      | <b>6</b>  |
| 1.1      | Purpose of this Operating Guide                          | 6         |
| 1.2      | Additional Resources                                     | 6         |
| 1.2.1    | Supplementary Documentation                              | 6         |
| 1.2.2    | VLT® Motion Control Tool MCT 10 Software Support         | 6         |
| 1.3      | Manual and Software Version                              | 6         |
| 1.4      | Approvals and Certifications                             | 6         |
| 1.5      | Disposal   | 7         |
| 1.6      | Declarations   | 8         |
| <b>2</b> | <b>Safety</b>  | <b>12</b> |
| 2.1      | Safety Symbols   | 12        |
| 2.2      | Qualified Personnel                                      | 12        |
| 2.3      | Safety Precautions                                       | 12        |
| <b>3</b> | <b>Installation</b>                                      | <b>14</b> |
| 3.1      | Mechanical Installation                                  | 14        |
| 3.1.1    | Side-by-side Installation                                | 14        |
| 3.1.2    | Operating Environment                                    | 14        |
| 3.1.2.1  | Derating for Ambient Temperature and Switching Frequency | 14        |
| 3.1.2.2  | Derating for Low Air Pressure and High Altitudes         | 14        |
| 3.2      | Electrical Installation                                  | 14        |
| 3.2.1    | Electrical Installation in General                       | 14        |
| 3.2.1.1  | Fastener Torque Ratings                                  | 14        |
| 3.2.2    | Fuses and Circuit Breakers                               | 15        |
| 3.2.2.1  | Recommendation of Fuses and Circuit Breakers             | 15        |
| 3.2.3    | Electrical Wiring  | 15        |
| 3.2.3.1  | Wiring Schematic   | 15        |
| 3.2.3.2  | Terminal Overview of Enclosure Sizes H3–H5               | 17        |
| 3.2.3.3  | Terminal Overview of Enclosure Size H6                   | 18        |
| 3.2.3.4  | Connecting to Mains and Compressor Terminals             | 18        |
| 3.2.3.5  | Relay Terminals  | 19        |
| 3.2.3.6  | Control Terminals  | 20        |
| 3.2.4    | Setting Up RS485 Serial Communication                    | 21        |
| 3.2.5    | EMC-compliant Electrical Installation                    | 22        |
| <b>4</b> | <b>Commissioning</b>                                     | <b>26</b> |
| 4.1      | Programming Interfaces                                   | 26        |

|          |   |           |
|----------|---|-----------|
| 4.2      | Local Control Panel (LCP)                                       | 26        |
| 4.2.1    | Programming via the Quick Menu                                  | 27        |
| 4.2.2    | Programming via the Main Menu                                   | 27        |
| 4.2.3    | Data Transfer from Drive to LCP                                 | 28        |
| 4.2.4    | Data Transfer from LCP to Drive                                 | 28        |
| 4.2.5    | Restoring Factory Default Settings                              | 28        |
| 4.2.5.1  | Recommended Initialization (via Parameter 14-22 Operation Mode) | 28        |
| 4.2.5.2  | Two-finger Initialization                                       | 29        |
| 4.3      | Starting Up the Drive for the First Time                        | 29        |
| <b>5</b> | <b>Troubleshooting</b>  | <b>30</b> |
| 5.1      | Acoustic Noise or Vibration                                     | 30        |
| 5.2      | Warnings and Alarms   | 30        |
| <b>6</b> | <b>Specifications</b>   | <b>34</b> |
| 6.1      | Electrical Data   | 34        |
| 6.1.1    | Electrical Data 3x200–240 V AC                                  | 34        |
| 6.1.2    | Electrical Data 3x380–480 V AC                                  | 34        |
| 6.2      | Mains Supply (L1, L2, L3)                                       | 35        |
| 6.3      | Compressor Output (U, V, W)                                     | 36        |
| 6.4      | Control Input/Output  | 36        |
| 6.4.1    | 10 V DC Output  | 36        |
| 6.4.2    | 24 V DC Output  | 36        |
| 6.4.3    | Analog Inputs   | 36        |
| 6.4.4    | Analog Outputs  | 36        |
| 6.4.5    | Digital Inputs  | 37        |
| 6.4.6    | Digital Outputs   | 37        |
| 6.4.7    | Relay Outputs, Enclosure Sizes H3–H5                            | 37        |
| 6.4.8    | Relay Outputs, Enclosure Size H6                                | 38        |
| 6.4.9    | RS485 Serial Communication                                      | 38        |
| 6.5      | Ambient Conditions  | 38        |
| 6.6      | Conforming Standards  | 39        |
| 6.7      | Cable Lengths and Cross-sections                                | 39        |
| 6.8      | Acoustic Noise  | 39        |
| 6.9      | Shipping Dimensions   | 40        |
| 6.10     | Accessories and Spare Parts                                     | 40        |
| <b>7</b> | <b>Appendix</b>   | <b>41</b> |
| 7.1      | Abbreviations   | 41        |

---

7.2 Conventions

42

## 1 Introduction

### 1.1 Purpose of this Operating Guide

This operating guide provides information for safe installation and commissioning of the AC drive. It is intended for use by qualified personnel.

Read and follow the instructions to use the drive safely and professionally.

Pay particular attention to the safety instructions and general warnings. Always keep this operating guide with the drive.

VLT® is a registered trademark for Danfoss A/S.

### 1.2 Additional Resources

#### 1.2.1 Supplementary Documentation

Other resources are available to understand advanced drive functions and programming.

- The *Programming Guide* provides information on how to program and includes complete parameter descriptions.
- The *Design Guide* provides detailed information about capabilities and functionality to design motor control systems.
- The *Modbus RTU Operating Instructions* explains how to physically establish and configure communication between the Danfoss VLT® Series and a controller using the Modbus RTU protocol. Download the Operating Instructions from [www.danfoss.com](http://www.danfoss.com) in the section *Service and Support/Documentation*.

See [www.danfoss.com](http://www.danfoss.com) for supplementary documentation.

#### 1.2.2 VLT® Motion Control Tool MCT 10 Software Support

Download the software from the Service and Support download page on [www.danfoss.com](http://www.danfoss.com).

During the installation process of the software, enter CD-key 34544400 to activate the CDS 803 functionality. An activation key is not required for using the CDS 803 functionality.

The latest software does not always contain the latest updates for the drive. Contact the local sales office for the latest drive updates (in the form of \*.upd files), or download the drive updates from the Service and Support download page on [www.danfoss.com](http://www.danfoss.com).



### 1.3 Manual and Software Version

This manual is regularly reviewed and updated. All suggestions for improvement are welcome.

**Table 1: Manual and Software Version**

| Edition                      | Remarks                         | Software version  |
|------------------------------|---------------------------------|---|
| AQ321748767627, version 0401 | Power sizes 11 and 15 kW added. | 6.0–10 kW (8–15 hp): Version 2.10<br>11–15 kW (15–20 hp): Version 51.00<br>18–30 kW (25–40 hp): Version 61.30 |

### 1.4 Approvals and Certifications

| Description   | Conformity mark   |
|---|---|
| <b>EU/EC Declaration of Conformity</b> (EC/CE - European Conformity/Conformité Européenne)<br>Low Voltage Directive/Electromagnetic compatibility (EMC)/Restriction of Hazardous Substances (RoHS)<br><b>Countries of use:</b> Europe |  |
| <b>UKCA Declaration of Conformity</b> (UKCA - UK Conformity Assessed)<br>Low Voltage Directive/Electromagnetic compatibility (EMC)/Restriction of Hazardous Substances (RoHS)<br><b>Countries of use:</b> Great Britain               |  |
| <b>ACMA Declaration of Conformity</b> (RCM - Regulatory Compliance Mark)<br>Australian Communications Media Authority (ACMA)<br>Low Voltage Directive/Electromagnetic compatibility (EMC)   |  |

| Description   | Conformity mark |
|---|-----------------|
| <b>Countries of use:</b> Australia and New Zealand  |                 |
| <b>VIT-SEPRO Declaration of Conformity</b> (VIT - All-Union Institute of Transformer Engineering)<br>Low Voltage Directive/Electromagnetic compatibility (EMC)<br><b>Country of use:</b> Ukraine  |                 |
| <b>Moroccan Declaration of Conformity</b> (CMIM - Moroccan Conformity Mark)<br>Low Voltage Directive/Electromagnetic compatibility (EMC)<br><b>Country of use:</b> Morocco  |                 |
| <b>Eurasian Economic Union Declaration of Conformity</b> (EAC - Eurasian Conformity Mark)<br>Customs Union Technical Regulations (CU TR)<br>Low voltage Directive/Electromagnetic compatibility (EMC)/Restriction of Hazardous Substances Directive (RoHS)<br><b>Countries of use:</b> Eurasian Economic Union (Russia, Belarus, Kazakhstan, Armenia, and Kyrgyzstan) |                 |
| <b>Certification of Compliance UL listed</b> (UL - Underwriters Laboratories)<br>Safety organization<br><b>Countries of use:</b> USA and Canada   |                 |
| <b>Certification of Compliance UL recognized</b> (UL - Underwriters Laboratories)<br>Safety organization<br><b>Countries of use:</b> USA and Canada   |                 |
| <b>KC Declaration of Conformity</b> (KC - Korea Certification)<br>Low Voltage Directive/Electromagnetic compatibility (EMC)/Restriction of Hazardous Substances (RoHS)<br><b>Countries of use:</b> Korea  |                 |

## NOTICE

The VLT® Compressor Drive CDS 803 with SXXX in the type code is certified against UL 508C/EN61800-5-1. Example:

CDS803P7K5T4E20H4XXCXXXSXXXXXAXBXCXXXXDX

The VLT® Compressor Drive CDS 803 with S129 in the type code is certified against EN/IEC 60730-1. Example:

CDS803P15KT4E20H2XXCXXXS129XAXBXCXXXXDX

The VLT® Compressor Drive CDS 803 with S096 in the type code is certified against UL/EN/IEC 60730-1. Example:

CDS803P30KT4E20H2XXXXXXS096XAXBXCXXXXDX

### 1.5 Disposal

|  |   |
|--|---|
|  | <p>Do not dispose of equipment containing electrical components together with domestic waste.<br/>Collect it separately in accordance with local and currently valid legislation.</p> |
|--|---|

### 1.6 Declarations

DocuSign Envelope ID: CDA99A52-665C-4D32-B325-E6DA2E929782

ENGINEERING  
TOMORROW



**Danfoss A/S**

6430 Nordborg  
Denmark  
CVR nr.: 20 16 57 15  
Telephone: +45 7488 2222  
Fax: +45 7449 0949

## EU DECLARATION OF CONFORMITY

### Danfoss A/S

#### Danfoss Drives

declares under our sole responsibility that the

**Product category:** Frequency Converter

**Type designation(s):** CDS803PXXYY\*\*\*\*\*

Character XXX: 6K0, 7K5, 10K, 11K, 15K, 18K, 22K, 30K

Character YY: T2, T4.

The meaning of the 39 characters in the type code string can be found in appendix 00729791.

Covered by this declaration is in conformity with the following directive(s), regulation(s), standard(s) or other normative document(s), provided that the product is used in accordance with our instructions.

**Low Voltage Directive 2014/35/EU**

6K0, 7K5, 10K :

EN61800-5-1:2007 + A1:2017

Adjustable speed electrical power drive systems – Part 5-1:  
Safety requirements – Electrical, thermal and energy.

11K, 15K, 18K, 22K, 30K :

EN60730-1:2016 + A1:2019

Automatic Electrical controls for house hold and similar use –  
Part1: General Requirements

**EMC Directive 2014/30/EU**

EN61800-3:2004 + A1:2012

Adjustable speed electrical power drive systems – Part 3: EMC  
requirements and specific test methods.

**RoHS Directive 2011/65/EU including amendment 2015/863.**

EN IEC63000:2018

Technical documentation for the assessment of electrical and  
electronic products with respect to the restriction of hazardous  
substances

|   |  |   |  |
|---|--|---|--|
| Date: 2023.03.02<br>Place of issue:<br><br>Graasten, DK | Issued by<br><br>DocuSigned by:<br>Signature: Dennis Sehn<br>Name: Dennis Sehn<br>Title: Technical Product Manager | Date: 2023.03.02<br>Place of issue:<br><br>Graasten, DK | Approved by<br><br>DocuSigned by:<br>Signature: Frank-Erik Johansen<br>Name: Frank-Erik Johansen<br>Title: Head of Customized Drives |
|---|--|---|--|

Danfoss only vouches for the correctness of the English version of this declaration. In the event of the declaration being translated into any other language, the translator concerned shall be liable for the correctness of the translation

ID No: 00730869  
This doc. is managed by 500B0577

Revision No: A,8

Page 1 of 4



DocuSign Envelope ID: CDA99A52-665C-4D32-B325-E6DA2E929782

**Commission Regulation (EU) 2019/1781 under the Ecodesign Directive 2009/125/EC including amendment in Commission Regulation (EU) 2021/341**  
EN61800-9-2:2017

Adjustable speed electrical power drive systems - Part 9-2:  
Ecodesign for power drive systems, motor starters, power  
electronics and their driven applications - Energy efficiency  
indicators for power drive systems and motor starters.

DocuSign Envelope ID: CDA99A52-665C-4D32-B325-E6DA2E929782

ENGINEERING  
TOMORROW



**Danfoss A/S**

6430 Nordborg  
Denmark  
CVR nr.: 20 16 57 15  
Telephone: +45 7488 2222  
Fax: +45 7449 0949

**UK DECLARATION OF CONFORMITY**

**Danfoss A/S**

**Danfoss Drives**

declares under our sole responsibility that the

**Product category:** Frequency Converter

**Type designation(s):** CDS803PXXXXY\*\*\*\*\*

Character XXX: 6K0, 7K5, 10K, 11K, 15K,18K, 22K, 30K

Character YY: T2, T4.

The meaning of the 39 characters in the type code string can be found in appendix 00729791.

Covered by this declaration is in conformity with the following directive(s), regulation(s), standard(s) or other normative document(s), provided that the product is used in accordance with our instructions.

**Electrical Equipment (Safety) Regulations 2016**

6K0, 7K5, 10K :

BS EN61800-5-1:2007 + A1:2017 Adjustable speed electrical power drive systems – Part 5-1: Safety requirements – Electrical, thermal and energy.

11K, 15K, 18K, 22K, 30K :

EN60730-1:2016 +A1:2019 Automatic Electrical controls for house hold and similar use – Part1: General Requirements

**Electromagnetic Compability Regulations 2016**

BS EN61800-3:2004 + A1:2012 Adjustable speed electrical power drive systems – Part 3: EMC requirements and specific test methods.

**The Restriction of the Use of Certain Hazardous Substances in Electrical and Electronic Equipment Regulations 2012 as amended**

BS EN IEC63000:2018 Technical documentation for the assessment of electrical and electronic products with respect to the restriction of hazardous substances

**Commission Regulation (EU) 2019/1781 under the Ecodesign Directive 2009/125/EC including amendment in Commission Regulation (EU) 2021/341**

|   |   |   |   |
|---|---|---|---|
| Date: 2023.03.02<br>Place of issue:<br>Graasten, DK | Issued by<br>DocuSigned by:<br>Signature: <b>Dennis Sehn</b><br>Name: Dennis Sehn<br>Title: Technical Product Manager | Date: 2023.03.02<br>Place of issue:<br>Graasten, DK | Approved by<br>DocuSigned by:<br>Signature: <b>Frank-Erik Johansen</b><br>Name: Frank-Erik Johansen<br>Title: Head of Customized Drives |
|---|---|---|---|

Danfoss only vouches for the correctness of the English version of this declaration. In the event of the declaration being translated into any other language, the translator concerned shall be liable for the correctness of the translation

ID No: 00730869  
This doc. is managed by 500B0577

Revision No: A,8

Page 3 of 4

DocuSign Envelope ID: CDA99A52-665C-4D32-B325-E6DA2E929782

BS EN61800-9-2:2017

Adjustable speed electrical power drive systems - Part 9-2:  
Ecodesign for power drive systems, motor starters, power  
electronics and their driven applications - Energy efficiency  
indicators for power drive systems and motor starters.

## 2 Safety

### 2.1 Safety Symbols

The following symbols are used in this guide:

#### ⚠ D A N G E R ⚠

Indicates a hazardous situation which, if not avoided, will result in death or serious injury.

#### ⚠ W A R N I N G ⚠

Indicates a hazardous situation which, if not avoided, could result in death or serious injury.

#### ⚠ C A U T I O N ⚠

Indicates a hazardous situation which, if not avoided, could result in minor or moderate injury.

#### N O T I C E

Indicates information considered important, but not hazard-related (for example, messages relating to property damage).

### 2.2 Qualified Personnel

To allow trouble-free and safe operation of the unit, only qualified personnel with proven skills are allowed to transport, store, assemble, install, program, commission, maintain, and decommission this equipment.

Persons with proven skills:

- Are qualified electrical engineers, or persons who have received training from qualified electrical engineers and are suitably experienced to operate devices, systems, plant, and machinery in accordance with pertinent laws and regulations.
- Are familiar with the basic regulations concerning health and safety/accident prevention.
- Have read and understood the safety guidelines given in all guides provided with the unit, especially the instructions given in the installation guide and safety guide.
- Have good knowledge of the generic and specialist standards applicable to the specific application.

### 2.3 Safety Precautions

#### ⚠ W A R N I N G ⚠

##### HAZARDOUS VOLTAGE

AC drives contain hazardous voltage when connected to the AC mains or connected on the DC terminals. Failure to perform installation, start-up, and maintenance by skilled personnel can result in death or serious injury.

- Only skilled personnel must perform installation, start-up, and maintenance.

#### ⚠ W A R N I N G ⚠

##### UNINTENDED START

When the drive is connected to AC mains, DC supply, or load sharing, the motor may start at any time. Unintended start during programming, service, or repair work can result in death, serious injury, or property damage. Start the motor with an external switch, a fieldbus command, an input reference signal from the local control panel (LCP), via remote operation using MCT 10 software, or after a cleared fault condition.

- Disconnect the drive from the mains.
- Press [Off/Reset] on the LCP before programming parameters.
- Ensure that the drive is fully wired and assembled when it is connected to AC mains, DC supply, or load sharing.

## ⚠ WARNING ⚠

### DISCHARGE TIME

The drive contains DC-link capacitors, which can remain charged even when the drive is not powered. High voltage can be present even when the warning indicator lights are off.

Failure to wait the specified time after power has been removed before performing service or repair work could result in death or serious injury.

- Stop the motor.
- Disconnect AC mains, permanent magnet type motors, and remote DC-link supplies, including battery back-ups, UPS, and DC-link connections to other drives.
- Wait for the capacitors to discharge fully. The minimum waiting time is specified in the table *Discharge time* and is also visible on the nameplate on the top of the drive.
- Before performing any service or repair work, use an appropriate voltage measuring device to make sure that the capacitors are fully discharged.

**Table 2: Discharge Time**

| Voltage [V] | Power range [kW (hp)] | Minimum waiting time (minutes) |
|-------------|-----------------------|--------------------------------|
| 3x200       | 6.0–10 (8.0–15)       | 15                             |
| 3x400       | 6.0–7.5 (8.0–10)      | 4                              |
| 3x400       | 10–30 (15–40)         | 15                             |

## ⚠ WARNING ⚠

### LEAKAGE CURRENT HAZARD

Leakage currents exceed 3.5 mA. Failure to ground the drive properly can result in death or serious injury.

- Ensure that the minimum size of the ground conductor complies with the local safety regulations for high touch current equipment.

## ⚠ WARNING ⚠

### EQUIPMENT HAZARD

Contact with rotating shafts and electrical equipment can result in death or serious injury.

- Ensure that only trained and qualified personnel perform installation, start-up, and maintenance.
- Ensure that electrical work conforms to national and local electrical codes.
- Follow the procedures in this manual.

## ⚠ CAUTION ⚠

### INTERNAL FAILURE HAZARD

An internal failure in the drive can result in serious injury when the drive is not properly closed.

- Ensure that all safety covers are in place and securely fastened before applying power.

## 3 Installation

### 3.1 Mechanical Installation

#### 3.1.1 Side-by-side Installation

The drive can be mounted side by side but requires the clearance specified in [Table 3](#) above and below for cooling.

Table 3: Clearance Required for Cooling

| Size | IP protection rating | Power [kW (hp)]  |                  | Clearance above/below [mm (in)] |
|------|----------------------|------------------|------------------|---------------------------------|
|      |                      | 3x200–240 V      | 3x380–480 V      |                                 |
| H3   | IP20                 | –                | 6.0–7.5 (8.0–10) | 100 (4)                         |
| H4   | IP20                 | 6.0–7.5 (8.0–10) | 10 (15)          | 100 (4)                         |
| H5   | IP20                 | 10 (15)          | 11–22 (15–30)    | 100 (4)                         |
| H6   | IP20                 | –                | 30(40)           | 200 (7.9)                       |

### N O T I C E

With IP21/NEMA Type1 option kit mounted, a distance of 50 mm (2 in) between the units is required.

### 3.1.2 Operating Environment

#### 3.1.2.1 Derating for Ambient Temperature and Switching Frequency

Ensure that the ambient temperature measured over 24 hours is at least 5 °C (9 °F) lower than the maximum ambient temperature that is specified for the drive. If the drive is operated at a high ambient temperature, decrease the constant output current. For derating specifications, see the VLT® Compressor Drive CDS 803 Design Guide listed in [1.2 Additional Resources](#).

#### 3.1.2.2 Derating for Low Air Pressure and High Altitudes

The cooling capability of air is decreased at low air pressure. For altitudes above 2000 m (6562 ft), contact Danfoss regarding PELV. Below 1000 m (3281 ft) altitude, derating is not necessary. For altitudes above 1000 m (3281 ft), decrease the ambient temperature or the maximum output current. Decrease the output by 1% per 100 m (328 ft) altitude above 1000 m (3281 ft) or reduce the maximum ambient cooling air temperature by 1 °C (1.8 °F) per 200 m (656 ft).

## 3.2 Electrical Installation

### 3.2.1 Electrical Installation in General

All cabling must comply with national and local regulations on cable cross-sections and ambient temperature. Copper conductors are required. 75 °C (167 °F) is recommended.

#### 3.2.1.1 Fastener Torque Ratings

Table 4: Tightening Torques for Enclosure Sizes H3–H6, 3x200–240 V & 3x380–480 V

| Power [kW (hp)] |                      |             |                  | Torque [Nm (in-lb)] |         |               |                   |         |         |
|-----------------|----------------------|-------------|------------------|---------------------|---------|---------------|-------------------|---------|---------|
| Enclosure size  | IP protection rating | 3x200–240 V | 3x380–480 V      | Mains               | Motor   | DC connection | Control terminals | Ground  | Relay   |
| H3              | IP20                 | –           | 6.0–7.5 (8.0–10) | 0.8 (7)             | 0.8 (7) | 0.8 (7)       | 0.5 (4)           | 0.8 (7) | 0.5 (4) |

| Power [kW (hp)] |      |                  |               | Torque [Nm (in-lb)] |          |          |         |         |         |
|-----------------|------|------------------|---------------|---------------------|----------|----------|---------|---------|---------|
| H4              | IP20 | 6.0–7.5 (8.0–10) | 10 (15)       | 1.2 (11)            | 1.2 (11) | 1.2 (11) | 0.5 (4) | 0.8 (7) | 0.5 (4) |
| H5              | IP20 | 10 (15)          | 11–22 (15–30) | 1.2 (11)            | 1.2 (11) | 1.2 (11) | 0.5 (4) | 0.8 (7) | 0.5 (4) |
| H6              | IP20 | –                | 30 (40)       | 4.5 (40)            | 4.5 (40) | –        | 0.5 (4) | 3 (27)  | 0.5 (4) |

### 3.2.2 Fuses and Circuit Breakers

Fuses and circuit breakers ensure that possible damage to the drive is limited to damage inside the unit. Danfoss recommends fuses on the supply side as protection. For further information, see the application note Fuses and Circuit Breakers found on [www.danfoss.com](http://www.danfoss.com) under *Service and support/Documentation/Manuals & guides*.

## NOTICE

Use of fuses on the supply side is mandatory for IEC 60364 (CE) and NEC 2009 (UL) compliant installations.

### 3.2.2.1 Recommendation of Fuses and Circuit Breakers

Table 5: Fuses and Circuit Breakers

| Power [kW (hp)]    | Circuit breakers <sup>(1)</sup> |        | Fuse     |          |          |          |              |       |
|--------------------|---------------------------------|--------|----------|----------|----------|----------|--------------|-------|
|                    | UL                              | Non-UL | UL       |          |          |          | Non-UL       |       |
|                    |                                 |        | Bussmann | Bussmann | Bussmann | Bussmann | Maximum fuse |       |
|                    |                                 |        | Type RK5 | Type RK1 | Type J   | Type T   | Type gG      |       |
| <b>3x200–240 V</b> |                                 |        |          |          |          |          |              |       |
| 6.0 (8.0)          | –                               | –      | FRS-R-50 | KTN-R50  | JKS-50   | JJN-50   | gG-50        |       |
| 7.5 (10)           |                                 |        | FRS-R-50 | KTN-R50  | JKS-50   | JJN-50   | gG-50        |       |
| 10 (15)            |                                 |        | FRS-R-80 | KTN-R80  | JKS-80   | JJN-80   | gG-63        |       |
| <b>3x380–480 V</b> |                                 |        |          |          |          |          |              |       |
| 6.0 (8.0)          | –                               | –      | FRS-R-25 | KTS-R25  | JKS-25   | JJS-25   | gG-25        |       |
| 7.5 (10)           |                                 |        | FRS-R-25 | KTS-R25  | JKS-25   | JJS-25   | gG-25        |       |
| 10 (15)            |                                 |        | FRS-R-50 | KTS-R50  | JKS-50   | JJS-50   | gG-50        |       |
| 11 (15)            |                                 |        | –        | –        | –        | –        | gG-63        |       |
| 15 (20)            |                                 |        | –        | –        | –        | –        | gG-63        |       |
| 18.5 (25)          |                                 |        | –        | –        | –        | –        | JJS-80       | gG-63 |
| 22 (30)            |                                 |        | –        | –        | –        | –        | JJS-80       | gG-63 |
| 30 (40)            |                                 |        | –        | –        | –        | –        | JJS-125      | gG-80 |

<sup>1</sup> Circuit breakers have not been evaluated by Danfoss as part of the certification process.

### 3.2.3 Electrical Wiring

#### 3.2.3.1 Wiring Schematic

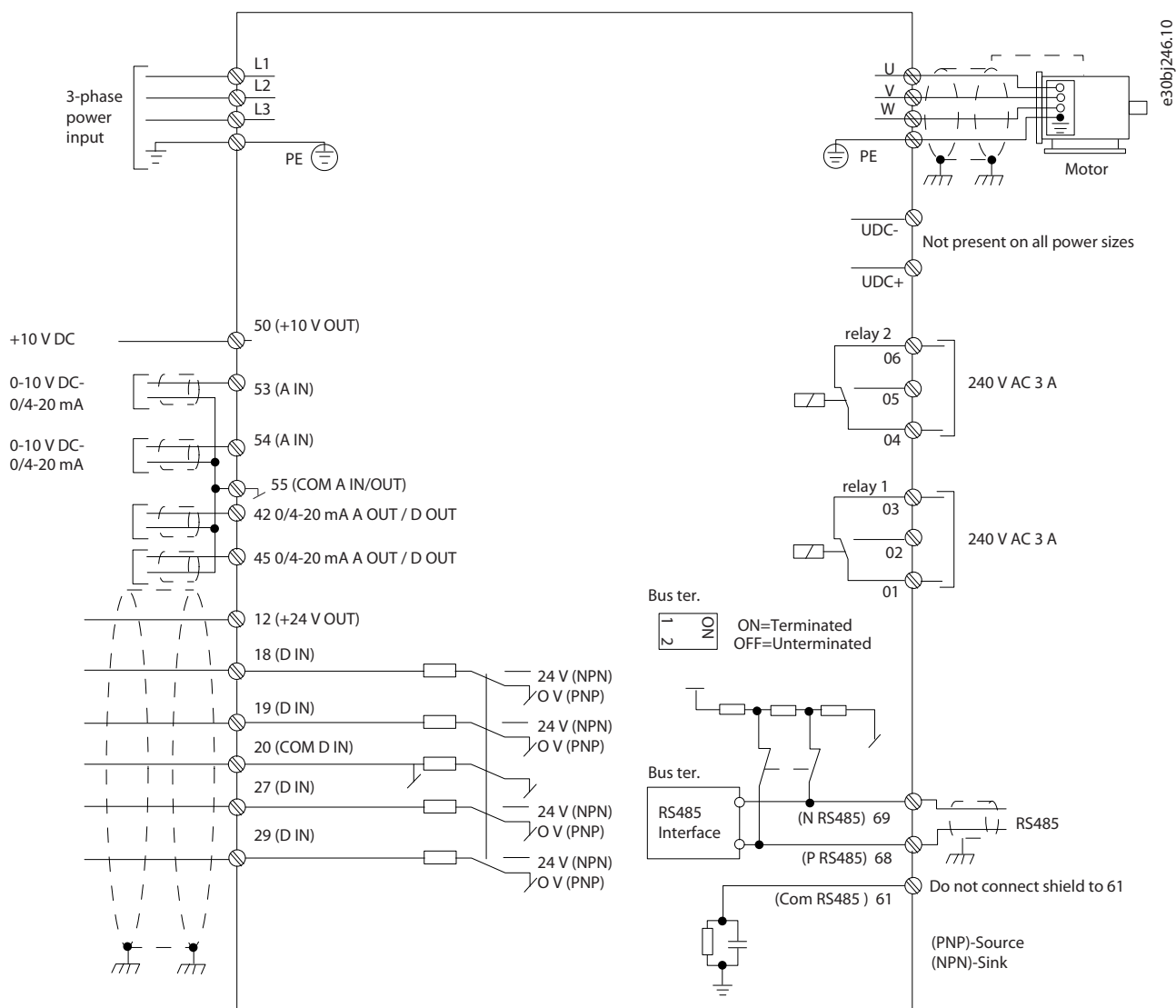

Illustration 1: Basic Wiring Schematic Drawing

## NOTICE

There is no access to UDC- and UDC+ on the following units:

- IP20, 380-480 V, 30 kW (40 hp).



### 3.2.3.2 Terminal Overview of Enclosure Sizes H3–H5

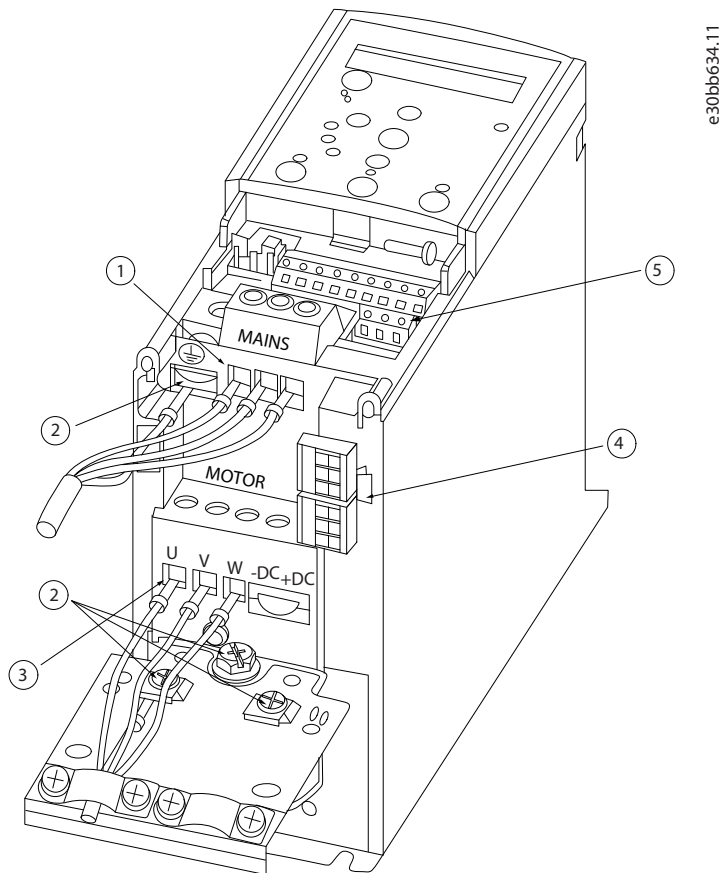

Illustration 2: Enclosure Sizes H3–H5

|   |            |   |                   |
|---|------------|---|-------------------|
| 1 | Mains      | 4 | Relays            |
| 2 | Ground     | 5 | Control terminals |
| 3 | Compressor |   |                   |

### 3.2.3.3 Terminal Overview of Enclosure Size H6

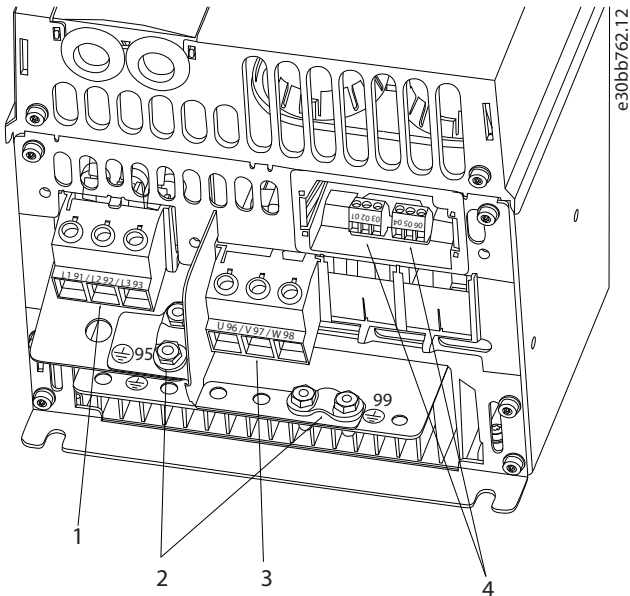

Illustration 3: Enclosure Size H6

|   |        |   |            |
|---|--------|---|------------|
| 1 | Mains  | 3 | Compressor |
| 2 | Ground | 4 | Relays     |

### 3.2.3.4 Connecting to Mains and Compressor Terminals

- Tighten all terminals in accordance with the information provided in [3.2.1.1 Fastener Torque Ratings](#).
- Keep the compressor cable as short as possible to reduce the noise level and leakage currents.
- Use a shielded/armored compressor cable to comply with the EMC emission specifications and connect this cable to both the decoupling plate and the compressor. Also see [3.2.5 EMC-compliant Electrical Installation](#).

1. Connect the ground cable to the ground terminal, then connect the mains supply to terminals L1, L2, and L3.

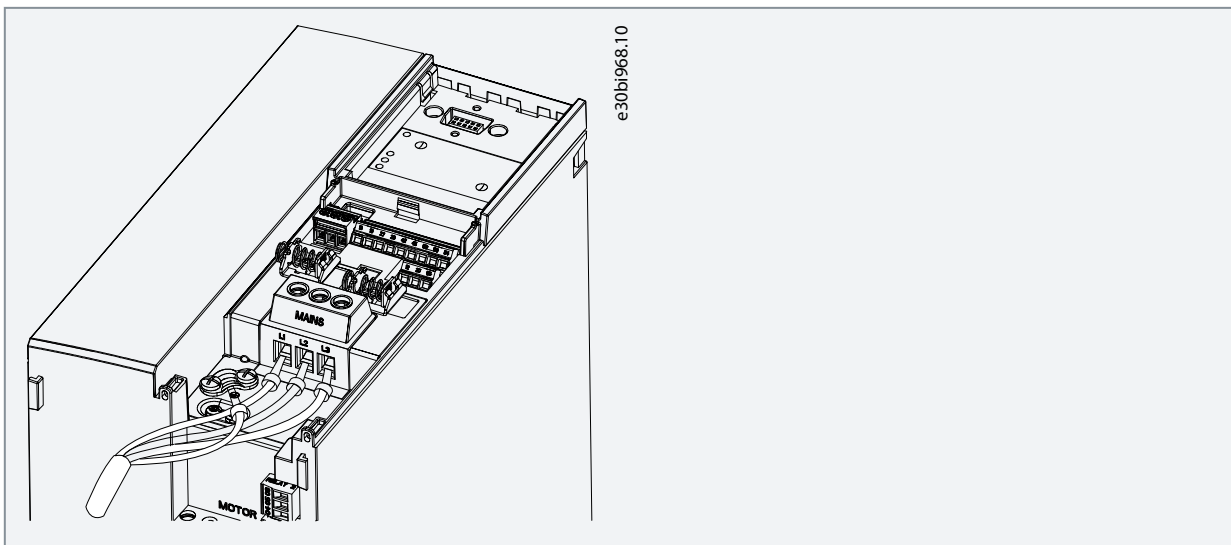

2. Connect the ground cable to the ground terminal, then connect the compressor to terminals U, V, and W.

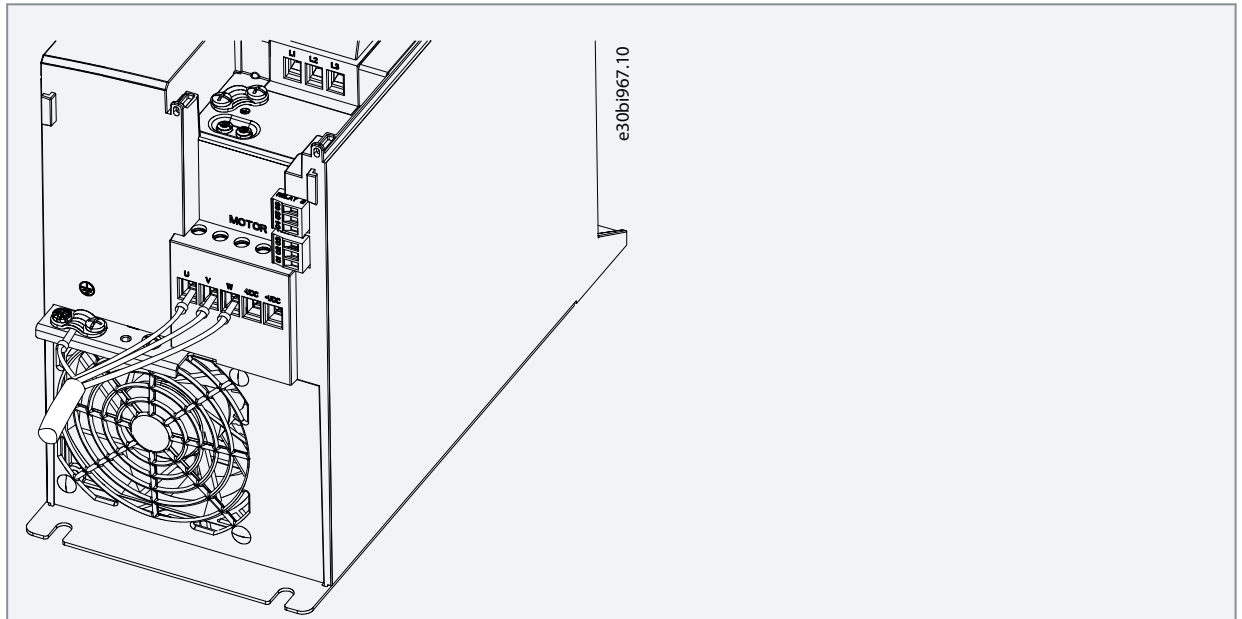

Table 6: Connection of Compressor to Terminals

| Drive terminals | Compressor |
|-----------------|------------|
| U               | T1         |
| V               | T2         |
| W               | T3         |

### 3.2.3.5 Relay Terminals

#### Relay 1

- Terminal 01: Common.
- Terminal 02: Normally open.
- Terminal 03: Normally closed.

#### Relay 2

- Terminal 04: Common.
- Terminal 05: Normally open.
- Terminal 06: Normally closed.

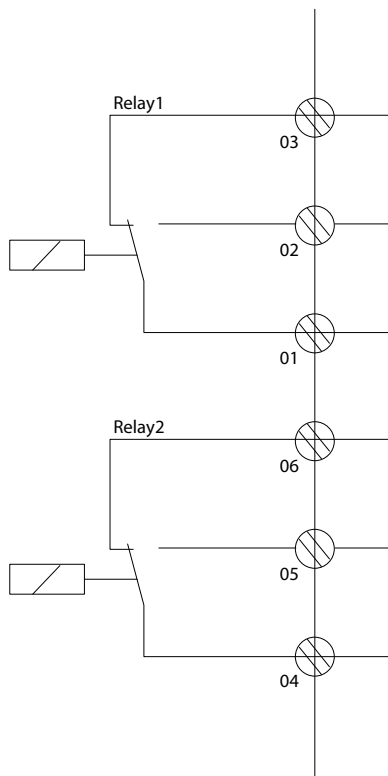

e30bi798.10

Illustration 4: Relay Outputs 1 and 2

### 3.2.3.6 Control Terminals

Remove the terminal cover to access the control terminals.

Use a flat-edged screwdriver to push down the lock lever of the terminal cover under the LCP, then remove the terminal cover as shown in the following illustration.

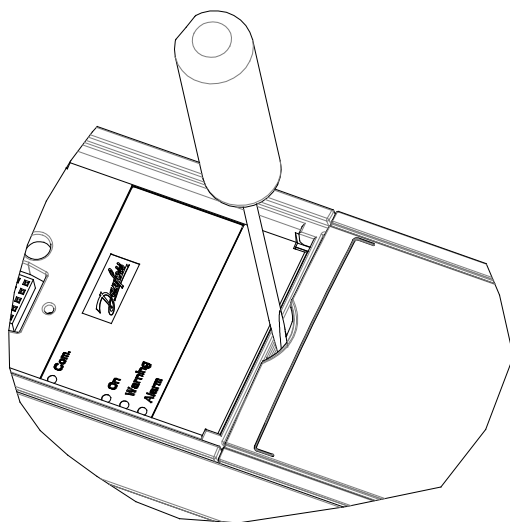

e30bd331.11

Illustration 5: Removing the Terminal Cover

The following illustration shows all the drive control terminals. Applying start (terminal 18), connection between terminals 12-27, and an analog reference (terminal 53 or 54, and 55) make the drive run.

The digital input mode of terminal 18, 19, 27, and 29 is set in *parameter 5-00 Digital Input Mode* (PNP is default value).

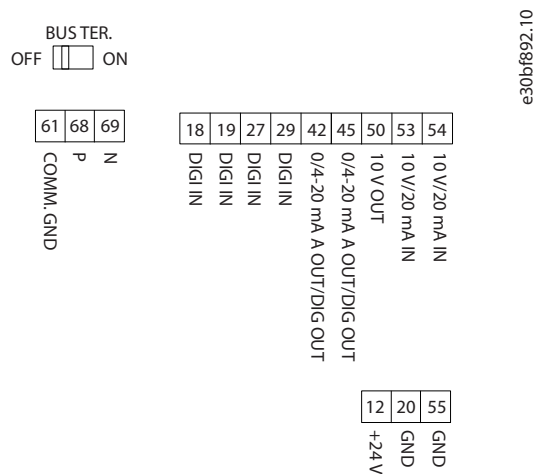

Illustration 6: Control Terminals

## 3.2.4 Setting Up RS485 Serial Communication

### 3.2.4.1 RS485 Features

RS485 is a 2-wire bus interface compatible with multi-drop network topology. This interface contains the following features:

- Ability to select from the following communication protocols:
  - FC (default protocol)
  - Modbus RTU
- Functions can be programmed remotely using the RS485 connection or in *parameter group 8-\*\* Communications and Options*.
- A switch (BUS TER) is provided on the control card for bus termination resistance.

## NOTICE

Altering between the supported communication protocols can be accessed and changed via the LCP as *parameter 8-30 Protocol* is not available in VLT® Motion Control Tool MCT 10.

### 3.2.4.2 Configuring RS485 Serial Communication

#### Procedure

1. Connect RS485 serial communication wiring to terminals (P RS485) 68 and (N RS485) 69.
  - Use shielded serial communication cable.
  - Properly ground the wiring. Refer to [3.2.5 EMC-compliant Electrical Installation](#).

- Configure all required settings such as address, baud rate, and so on in *parameter group 8-\*\* Communications and Options*. For more details on parameters, refer to VLT® Compressor Drive CDS 803 Programming Guide listed in [1.2 Additional Resources](#).

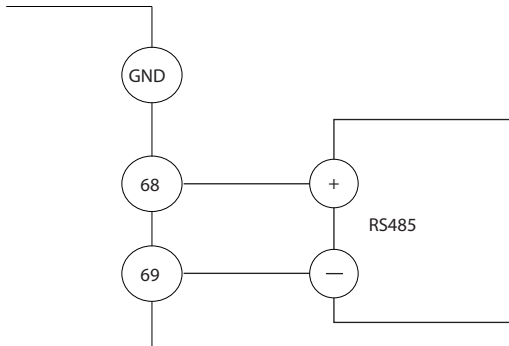
**Example**

e30bi768.10

**Illustration 7: RS485 Wiring Connection****3.2.5 EMC-compliant Electrical Installation**

To obtain an EMC-compliant installation, be sure to follow all electrical installation instructions. Also, remember to practice the following:

- When using relays, control cables, a signal interface, fieldbus, or brake, connect the shield to the enclosure at both ends. If the ground path has high impedance, is noisy, or is carrying current, break the shield connection on 1 end to avoid ground current loops.
- Convey the currents back to the unit using a metal mounting plate. Ensure good electrical contact from the mounting plate by securely fastening the mounting screws to the drive chassis.
- Use shielded cables for motor output cables. An alternative is unshielded motor cables within metal conduit.
- Ensure that motor and brake cables are as short as possible to reduce the interference level from the entire system.
- Avoid placing cables with a sensitive signal level alongside motor and brake cables.
- For communication and command/control lines, follow the particular communication protocol standards. For example, USB must use shielded cables, but RS485/ethernet can use shielded UTP or unshielded UTP cables.
- Ensure that all control terminal connections are rated protective extra low voltage (PELV).

**NOTICE****TWISTED SHIELD**

Twisted shield ends increase shield impedance at higher frequencies, which increases the leakage current.

- Use integrated shield clamps instead of twisted shield ends.

**NOTICE****SHIELDED CABLES**

If shielded cables or metal conduits are not used, the unit and the installation do not meet regulatory limits on radio frequency (RF) emission levels.

**NOTICE****EMC INTERFERENCE**

Failure to isolate power, motor, and control cables can result in unintended behavior or reduced performance.

- Use shielded cables for motor and control wiring.
- Provide a minimum 200 mm (7.9 in) separation between mains input, motor cables, and control cables.

**N O T I C E****EMI/EMC NON-COMPLIANCE**

Panel components not installed by Danfoss will invalidate the EMI/EMC compliance and other certifications.

**N O T I C E****INSTALLATION AT HIGH ALTITUDE**

There is a risk for overvoltage. Isolation between components and critical parts could be insufficient and may not comply with PELV requirements.

- Use external protective devices or galvanic isolation. For installations above 2000 m (6500 ft) altitude, contact Danfoss regarding protective extra low voltage (PELV) compliance.

**N O T I C E****PROTECTIVE EXTRA LOW VOLTAGE (PELV) COMPLIANCE**

Prevent electric shock by using PELV electrical supply and complying with local and national PELV regulations.

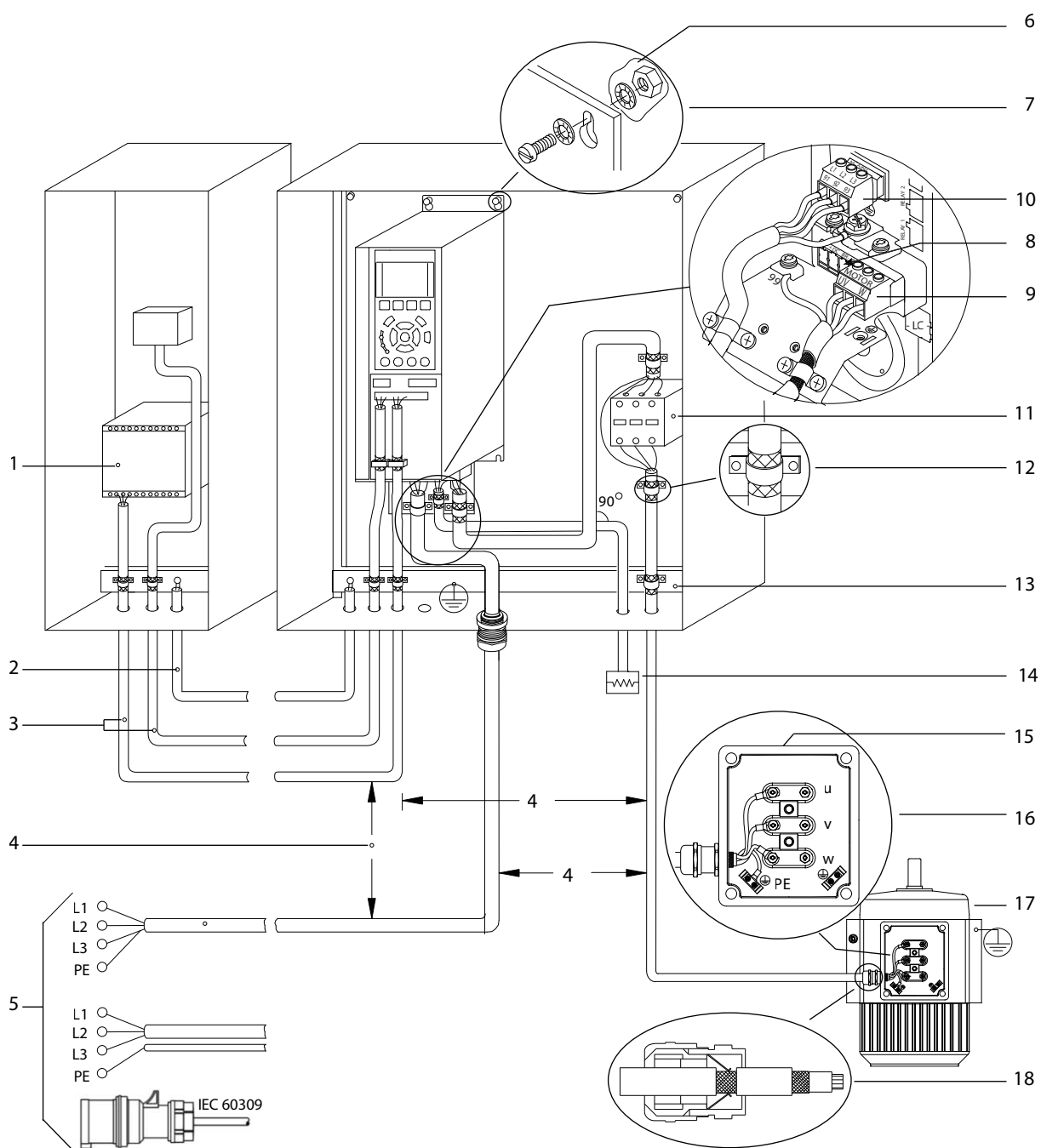

Illustration 8: Example of Proper EMC Installation



|   |  |    |   |
|---|--|----|---|
| 1 | Programmable logic controller (PLC)  | 10 | Mains cable (unshielded)  |
| 2 | Minimum 16 mm <sup>2</sup> (6 AWG) equalizing cable                            | 11 | Output contactor  |
| 3 | Control cables   | 12 | Cable insulation stripped   |
| 4 | Minimum 200 mm (7.9 in) between control cables, motor cables, and mains cables | 13 | Common ground busbar. Follow local and national requirements for cabinet grounding. |
| 5 | Mains supply   | 14 | Brake resistor  |
| 6 | Bare (unpainted) surface   | 15 | Metal box   |
| 7 | Star washers   | 16 | Connection to motor   |
| 8 | Brake cable (shielded)   | 17 | Motor   |
| 9 | Motor cable (shielded)   | 18 | EMC cable gland   |

## 4 Commissioning

### 4.1 Programming Interfaces

The drive can be programmed in 3 different ways:

- Locally via the LCP.
- Externally via the RS485 interface by either
  - using Modbus RTU
  - or by installing VLT® Motion Control Tool MCT 10.

For the full menu and parameter specifications, refer to the VLT® Compressor Drive CDS 803 Programming Guide listed in [1.2 Additional Resources](#).

### 4.2 Local Control Panel (LCP)

The LCP is divided into 4 functional sections.

- A. Display
- B. Menu key
- C. Navigation keys and indicator lights
- D. Operation keys and indicator lights

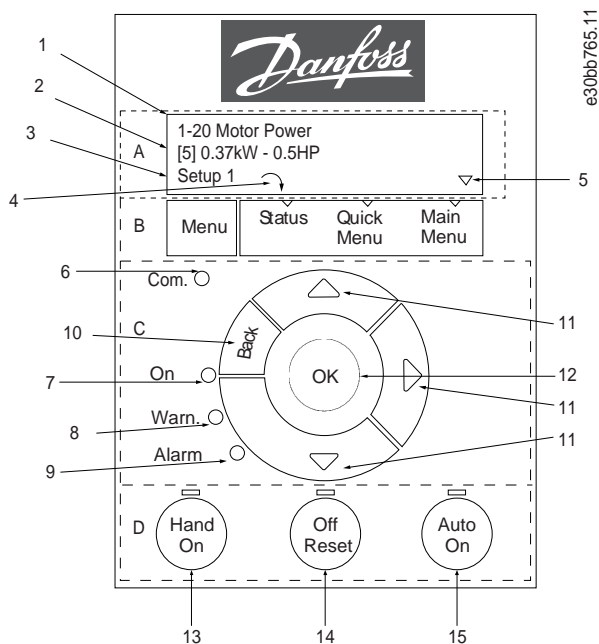

Illustration 9: Local Control Panel (LCP)

#### A. Display

The LCD display is illuminated with 2 alphanumeric lines. [Table 7](#) describes the information that can be read from the display.

Table 7: Legend to Section A

|   |                            |
|---|----------------------------|
| 1 | Parameter number and name. |
| 2 | Parameter value.           |

|   |   |
|---|---|
| 3 | Setup number shows the active setup and the edit setup. If the same setup acts as both active and edit setup, only that setup number is shown (factory setting). When active and edit setup differ, both numbers are shown in the display (setup 12). The number flashing indicates the edit setup. |
| 4 | Motor direction is shown to the bottom left of the display – indicated by a small arrow pointing either clockwise or counter-clockwise.   |
| 5 | The triangle indicates if the LCP is in Status, Quick Menu, or Main Menu.   |

### B. Menu key

Press [Menu] to select among Status, Quick Menu, or Main Menu.

### C. Navigation keys and indicator lights

Table 8: Legend to Section C

|    |  |
|----|--|
| 6  | Com. (yellow indicator): Flashes during bus communication.   |
| 7  | On (green indicator): Control section is working correctly.  |
| 8  | Warn. (yellow indicator): Indicates a warning.   |
| 9  | Alarm (red indicator): Indicates an alarm.   |
| 10 | [Back]: For moving to the previous step or layer in the navigation structure.  |
| 11 | [▲] [▼] [▶]: For navigating among parameter groups and parameters, and within parameters. They can also be used for setting local reference. |
| 12 | [OK]: For selecting a parameter and for accepting changes to parameter settings.   |

### D. Operation keys and indicator lights

Table 9: Legend to Section D

|  |  |
|--|--|
| 13   | [Hand On]: Starts the motor and enables control of the drive via the LCP.                |
| <div style="background-color: #cccccc; padding: 5px; margin: 5px 0;"><b>NOTICE</b></div> <p>[2] Coast inverse is the default option for <i>parameter 5-12 Terminal 27 Digital Input</i>. If there is no 24 V supply to terminal 27, [Hand On] does not start the compressor. Connect terminal 12 to terminal 27.</p> |  |
| 14   | [Off/Reset]: Stops the compressor (Off). If in alarm mode, the alarm is reset.           |
| 15   | [Auto On]: The drive is controlled either via control terminals or serial communication. |

## 4.2.1 Programming via the Quick Menu

### Procedure

1. To enter the *Quick Menu*, press [Menu] until indicator in display is placed above *Quick Menu*.
2. Press [▲] [▼] to select quick guide, closed-loop setup, compressor setup, or changes made, then press [OK].
3. Press [▲] [▼] to browse through the parameters in the *Quick Menu*.
4. Press [OK] to select a parameter.
5. Press [▲] [▼] to change the value of a parameter setting.
6. Press [OK] to accept the change.
7. Press either [Back] twice to enter *Status*, or press [Menu] once to enter *Main Menu*.

## 4.2.2 Programming via the Main Menu

### Procedure

1. Press [Menu] until the indicator in the display is placed above *Main Menu*.

2. Press [ $\Delta$ ] [ $\nabla$ ] to browse through the parameter groups.
3. Press [OK] to select a parameter group.
4. Press [ $\Delta$ ] [ $\nabla$ ] to browse through the parameters in the specific group.
5. Press [OK] to select the parameter.
6. Press [ $\Delta$ ] [ $\nabla$ ] to set/change the parameter value.
7. Press [OK] to accept the change or press [Back] to go back to the previous level.

### 4.2.3 Data Transfer from Drive to LCP

Once the setup of a drive is complete, Danfoss recommends storing the data in the LCP or on a PC via VLT® Motion Control Tool MCT 10.

#### ! W A R N I N G !

Stop the compressor before performing this operation.

#### Procedure

1. Go to *parameter 0-50 LCP Copy*.
2. Press [OK].
3. Select [1] *All to LCP*.
4. Press [OK].

### 4.2.4 Data Transfer from LCP to Drive

Connect the LCP to another drive to copy the parameter settings to this drive as well.

#### ! W A R N I N G !

Stop the compressor before performing this operation.

#### Procedure

1. Go to *parameter 0-50 LCP Copy*.
2. Press [OK].
3. Select [2] *All from LCP*.
4. Press [OK].

### 4.2.5 Restoring Factory Default Settings

There are 2 different ways of initializing the drive to factory default settings:

- Via *parameter 14-22 Operation Mode* (this is the recommended way).
- Two-finger initialization

Some parameters will not be reset, see more details in [4.2.5.1 Recommended Initialization \(via Parameter 14-22 Operation Mode\)](#) and [4.2.5.2 Two-finger Initialization](#).

#### 4.2.5.1 Recommended Initialization (via Parameter 14-22 Operation Mode)

Initialization of the drive to default settings (via *parameter 14-22 Operation Mode*).

#### Procedure

1. Select *parameter 14-22 Operation Mode*.
2. Press [OK].
3. Select [2] *Initialisation* and press [OK].
4. Cut off the mains supply and wait until the display turns off.
5. Reconnect the mains supply.

➡ The drive is now reset, except the following parameters:

- *Parameter 1-06 Clockwise Direction*
- *Parameter 1-13 Compressor Selection*

- *Parameter 4-18 Current Limit*
- *Parameter 8-30 Protocol*
- *Parameter 8-31 Address*
- *Parameter 8-32 Baud Rate*
- *Parameter 8-33 Parity / Stop Bits*
- *Parameter 8-35 Minimum Response Delay*
- *Parameter 8-36 Maximum Response Delay*
- *Parameter 8-37 Maximum Inter-char delay*
- *Parameter 15-00 Operating hours to parameter 15-05 Over Volt's*
- *Parameter 15-03 Power Up's*
- *Parameter 15-04 Over Temp's*
- *Parameter 15-05 Over Volt's*
- *Parameter 15-30 Alarm Log: Error Code*
- *Parameter group 15-4\* Drive identification parameters*

#### 4.2.5.2 Two-finger Initialization

##### Procedure

1. Power off the drive.
2. Press [OK] and [Menu].
3. Power up the drive while still pressing the keys above for 10 s.

➡ The drive is now reset, except the following parameters:

- *Parameter 1-06 Clockwise Direction*
- *Parameter 15-00 Operating hours*
- *Parameter 15-03 Power Up's*
- *Parameter 15-04 Over Temp's*
- *Parameter 15-05 Over Volt's*
- *Parameter 15-30 Alarm Log: Error Code*
- *Parameter group 15-4\* Drive identification parameters*

Initialization of parameters is confirmed by AL80 in the display after the power cycle.

#### 4.3 Starting Up the Drive for the First Time

The procedure in this section requires user-wiring and application programming to be completed. The following procedure is recommended after application setup is completed.

1. Press [Auto On].

If warnings or alarms occur, see the *Warnings and Alarms* section.

2. Apply an external run command. Examples of external run commands are a switch, button, or programmable logic controller (PLC).
3. Adjust the speed reference throughout the speed range.
4. Ensure that the system is working as intended by checking the sound and vibration levels of the compressor.
5. Remove the external run command.

## 5 Troubleshooting

### 5.1 Acoustic Noise or Vibration

If the compressor application makes noise or vibrations at certain frequencies, adjust the following parameters to avoid resonance problems within the system.

- Upper and lower frequency limits, *parameter group 4-6\* Speed Bypass*.
- Switching pattern and switching frequency, *parameter group 14-0\* Inverter Switching*.

### 5.2 Warnings and Alarms

A warning or an alarm is signaled by the relevant indicator on the front of the drive and indicated by a code on the display.

A warning remains active until its cause is no longer present. Under certain circumstances, operation of the compressor may still be continued. Warning messages may be critical.

In the event of an alarm, the drive has tripped. To restart operation, reset alarms once their cause has been rectified.

**This may be done in 4 ways:**

- By pressing [Reset].
- Via a digital input with the reset function.
- Via serial communication.
- By resetting automatically using the [Auto Reset] function, see *parameter 14-20 Reset Mode*.

A trip is the action following an alarm. The trip coasts the compressor and is reset by pressing [Reset] or by a digital input (*parameter group 5-1\* Digital Inputs*). The original event that caused an alarm cannot damage the drive or cause dangerous conditions. A trip lock is an action when an alarm occurs, which could damage the drive or connected parts. A trip lock situation can only be reset by cycling power.

Refer to the VLT® Compressor Drive CDS 803 Programming Guide listed in [1.2 Additional Resources](#) for parameter details and programming.

Table 10: Indicator Lights

| Status  | Color                 |
|---------|-----------------------|
| Warning | Constant yellow light |
| Alarm   | Flashing red light    |

The alarm words, warning words, and extended status words can be readout via serial bus or optional fieldbus for diagnosis. See also *parameter 16-90 Alarm Word*, *parameter 16-92 Warning Word*, and *parameter 16-94 Ext. Status Word*.

## N O T I C E

### MOTOR RESTART

After a manual reset pressing [Reset], press [Auto On] or [Hand On] to restart the motor.

If an alarm cannot be reset, the reason may be that its cause has not been rectified, or the alarm is trip-locked, see [Table 11](#).

## ⚠ C A U T I O N ⚠

### ALARM RESET

Alarms that are trip-locked offer extra protection, meaning that the mains supply must be switched off before the alarm can be reset. After being switched back on, the drive is no longer blocked and may be reset as described above once the cause has been rectified.

Alarms that are not trip-locked can also be reset using the automatic reset function in *parameter 14-20 Reset Mode* (Warning: automatic wake-up is possible!) [Table 11](#) specifies whether a warning occurs before an alarm, or whether to show a warning or an alarm for a given fault.

Table 11: Warnings and Alarms

| Fault number | Fault text       | Warn-<br>ing     | Alarm | Trip<br>locked   | Cause of problem   |
|--------------|------------------|------------------|-------|------------------|--|
| 2            | Live zero error  | X                | X     |                  | Signal on terminal 53 or 54 is less than 50% of the value set in <i>parameter 6-10 Terminal 53 Low Voltage</i> , <i>parameter 6-12 Terminal 53 Low Current</i> , <i>parameter 6-20 Terminal 54 Low Voltage</i> , or <i>parameter 6-22 Terminal 54 Low Current</i> . See also <i>parameter group 6-0* Analog I/O Mode</i> . |
| 3            | No motor         | X <sup>(1)</sup> |       |                  | No motor is connected.   |
| 4            | Mains ph. loss   | X                | X     | X                | Missing phase on the supply side or too high voltage imbalance. Check the supply voltage. See <i>parameter 14-12 Response to Mains Imbalance</i> .   |
| 7            | DC over volt     | X                | X     |                  | DC-link voltage exceeds limit.   |
| 8            | DC under volt    | X                | X     |                  | DC-link voltage drops below <i>voltage warning low limit</i> .   |
| 9            | Inverter overld. | X                | X     |                  | More than 100% load for too long.  |
| 10           | Motor ETR over   | X <sup>(2)</sup> | X     |                  | The compressor is too hot due to more than 100% load for too long.   |
| 11           | Motor th over    | X                | X     |                  | The thermistor or the thermistor connection is disconnected.   |
| 13           | Overcurrent      | X                | X     | X                | Inverter peak current limit is exceeded.   |
| 14           | Earth Fault      | X                | X     | X                | Discharge from output phases to ground.  |
| 16           | Short Circuit    |                  | X     | X                | Short circuit in the motor or on the motor terminals.  |
| 17           | Ctrl. word TO    | X                | X     |                  | No communication to the drive. See <i>parameter group 8-0* General Settings</i> .  |
| 18           | Start failed     |                  | X     |                  | The speed has not been able to exceed <i>parameter 1-78 Motor Start Min Speed [Hz]</i> during start within the allowed time.   |
| 30           | U phase loss     |                  | X     | X <sup>(2)</sup> | Motor phase U is missing. Check the phase.<br>For 6–10 kW drives: See <i>parameter 4-58 Missing Motor Phase Function</i> .   |
| 31           | V phase loss     |                  | X     | X <sup>(2)</sup> | Motor phase V is missing. Check the phase.<br>For 6–10 kW drives: See <i>parameter 4-58 Missing Motor Phase Function</i> .   |
| 32           | W phase loss     |                  | X     | X <sup>(2)</sup> | Motor phase W is missing. Check the phase.<br>For 6–10 kW drives: See <i>parameter 4-58 Missing Motor Phase Function</i> .   |
| 36           | Mains failure    | X                | X     |                  | Supply voltage to the drive is lost.   |
| 38           | Internal fault   |                  | X     | X                | Contact the local Danfoss supplier.  |

| Fault number | Fault text                      | Warning          | Alarm | Trip locked | Cause of problem  |
|--------------|---------------------------------|------------------|-------|-------------|---|
| 46           | Gate drive voltage fault        |                  | X     | X           | The supply on the power card is out of range.   |
| 47           | 24V supply low                  | X                | X     | X           | 24 V DC may be overloaded.  |
| 49           | Speed limit                     |                  | X     |             | The compressor runs at a speed lower than specified in <i>parameter 1-87 Compressor Min Speed for Trip [Hz]</i> .   |
| 50           | AMA calibration                 |                  | X     |             | AMA calibration failed.   |
| 51           | AMA check<br>$U_{nom}, I_{nom}$ |                  | X     |             | Motor voltage, current, and power configured wrong in parameters.   |
| 52           | AMA low, $I_{nom}$              |                  | X     |             | Motor current too low.  |
| 53           | AMA big motor                   |                  | X     |             | Motor is too large for the AMA to be performed.   |
| 54           | AMA small mot                   |                  | X     |             | Motor is too small for the AMA to be performed.   |
| 55           | AMA par. range                  |                  | X     |             | Parameter values found is outside of the acceptable range.  |
| 56           | AMA interrupt                   |                  | X     |             | The AMA is interrupted by user.   |
| 57           | AMA timeout                     |                  | X     |             | The AMA takes too long time to complete.  |
| 58           | AMA internal                    |                  | X     |             | Contact the local Danfoss supplier.   |
| 59           | Current limit                   | X                | X     |             | The current exceeds the value in <i>parameter 4-18 Current Limit</i> .  |
| 60           | External interlock              |                  | X     |             | External interlock has been activated. To resume normal operation, apply 24 V DC to the terminal programmed for external interlock and reset the drive (via serial communication, digital I/O, or by pressing [Off/Reset]). |
| 66           | Heat Sink Temperature Low       | X <sup>(3)</sup> |       |             | This warning is based on the temperature sensor in the IGBT module.   |
| 69           | Pwr. Card Temp                  | X                | X     | X           | The internal temperature has exceeded the allowed operating boundary. Check that the ambient operating temperature is within the limits. Check the fan operation.   |
| 80           | Drive initialized               |                  | X     |             | All parameter settings are initialized to default settings.   |
| 87           | Auto DC Braking                 | X                |       |             | The drive is auto DC braking.   |
| 96           | Start delayed                   | X                |       |             | Power to the drive has been on for a shorter time than specified in <i>parameter 28-01 Interval Between Starts</i> twice.   |
| 97           | Stop delayed                    | X                |       |             | Stopping the motor has been delayed due to short cycle protection being active.   |
| 99           | Locked rotor                    |                  | X     |             | The rotor is blocked or cannot run due to heavy load.   |



| Fault number | Fault text        | Warn-<br>ing | Alarm | Trip<br>locked | Cause of problem   |
|--------------|-------------------|--------------|-------|----------------|--|
| 126          | Motor Rotating    |              | X     |                | High back EMF voltage. Stop the rotor of the PM motor.   |
| 127          | Back EMF too high | X            |       |                | The drive cannot start the motor due to the rotor running at a higher speed than normal condition. |
| 208          | ORM Fault         |              | X     | X              | Running in hand mode with low speed for too long time.   |

<sup>1</sup> Only applicable for 11–30 kW.

<sup>2</sup> Only applicable for 6–10 kW.

<sup>3</sup> Only applicable for 30 kW.

For full specifications of warnings and alarms, refer to the VLT® Compressor Drives CDS 803 Programming Guide listed in [1.2 Additional Resources](#).

## 6 Specifications

### 6.1 Electrical Data

#### 6.1.1 Electrical Data 3x200–240 V AC

Table 12: 3x200–240 V AC

|   | P6K0       | P7K5       | P10K       |
|---|------------|------------|------------|
| Typical shaft output [kW]   | 6.0        | 7.5        | 10         |
| Typical shaft output [hp]   | 8.0        | 10         | 15         |
| Enclosure size  | H4         | H4         | H5         |
| Maximum cable size in terminals (mains, compressor) [mm <sup>2</sup> (AWG)]                   | 16 (6)     | 16 (6)     | 16 (6)     |
| <b>Output current @ 40 °C (104 °F) ambient temperature</b>                                    |            |            |            |
| Continuous (3x200–240 V) [A]  | -          | -          | -          |
| Intermittent (3x200–240 V) [A]  | -          | -          | -          |
| <b>Output current @ 50 °C (122 °F) ambient temperature</b>                                    |            |            |            |
| Continuous (3x200–240 V) [A]  | 20.7       | 25.9       | 33.7       |
| Intermittent (3x200–240 V) [A]  | 22.8       | 28.5       | 37.1       |
| <b>Maximum input current</b>  |            |            |            |
| Continuous (3x200–240 V) [A]  | 23.0       | 28.3       | 37.0       |
| Intermittent (3x200–240 V) [A]  | 25.3       | 31.1       | 40.7       |
| Maximum mains fuses, see <a href="#">3.2.2.1 Recommendation of Fuses and Circuit Breakers</a> |            |            |            |
| Estimated power loss [W] <sup>(1)</sup>   | 182        | 229        | 369        |
| Weight enclosure protection IP20 [kg (lb)]  | 7.9 (17.4) | 7.9 (17.4) | 9.5 (22.9) |
| Efficiency [%] <sup>(2)</sup>   | 97.3       | 98.5       | 97.2       |

<sup>1</sup> Applies to dimensioning of drive cooling. If the switching frequency is higher than the default setting, the power losses may increase. LCP and typical control card power consumptions are included. For power loss data according to EN 50598-2, refer to Danfoss [MyDrive® ecoSmart](#) website.

<sup>2</sup> Efficiency measured at nominal current. For energy efficiency class, see [6.6 Conforming Standards](#). For part load losses, see Danfoss [MyDrive® ecoSmart](#) website.

#### 6.1.2 Electrical Data 3x380–480 V AC

Table 13: 3x380–480 V AC

|  | P6K0   | P7K5   | P10K   | P11K   | P15K   | P18K   | P22K   | P30K   |
|--|--------|--------|--------|--------|--------|--------|--------|--------|
| Typical shaft output [kW]  | 6.0    | 7.5    | 10     | 11     | 15     | 18.5   | 22     | 30     |
| Typical shaft output [hp]  | 8.0    | 10     | 15     | 15     | 20     | 25     | 30     | 40     |
| Enclosure size   | H3     | H3     | H4     | H5     | H5     | H5     | H5     | H6     |
| Maximum cable size in terminals (mains, motor) [mm <sup>2</sup> (AWG)] | 4 (10) | 4 (10) | 16 (6) | 16 (6) | 16 (6) | 16 (6) | 16 (6) | 35 (2) |

|   | P6K0      | P7K5      | P10K       | P11K       | P15K       | P18K       | P22K       | P30K      |
|---|-----------|-----------|------------|------------|------------|------------|------------|-----------|
| <b>Output current @ 40 °C (104 °F) ambient temperature (45 °C (113 °F) for 30 kW)</b>           |           |           |            |            |            |            |            |           |
| Continuous (3x380–440 V) [A]  | -         | -         | -          | 23         | 31         | 37         | 44         | 61        |
| Intermittent (3x380–440 V)[A]   | -         | -         | -          | 25.3       | 34.1       | 40.7       | 48.4       | 67.1      |
| Continuous (3x441–480 V) [A]  | -         | -         | -          | 23         | 31         | 37         | 44         | 61        |
| Intermittent (3x441–480 V) [A]  | -         | -         | -          | 25.3       | 25.3       | 40.7       | 48.4       | 67.1      |
| <b>Output current @ 50 °C (122 °F) ambient temperature (52 °C (125 °F) for 11–22 kW)</b>        |           |           |            |            |            |            |            |           |
| Continuous (3x380–440 V) [A]  | 11.6      | 14.3      | 16.4       | 23         | 31         | 37         | 44         | 48.8      |
| Intermittent (3x380–440 V) [A]  | 12.8      | 15.7      | 18         | 25.3       | 34.1       | 40.7       | 48.4       | 53.7      |
| Continuous (3x441–480 V) [A]  | 9.8       | 12.3      | 15.5       | 23         | 31         | 37         | 44         | 41.6      |
| Intermittent (3x441–480 V) [A]  | 10.8      | 13.5      | 17.1       | 25.3       | 34.1       | 40.7       | 48.4       | 45.8      |
| <b>Maximum input current</b>  |           |           |            |            |            |            |            |           |
| Continuous (3x380–440 V) [A]  | 12.7      | 15.1      | 18         | 22.1       | 29.9       | 35.2       | 42.6       | 57        |
| Intermittent (3x380–440 V) [A]  | 14        | 16.6      | 19.8       | 24.3       | 32.9       | 38.7       | 45.7       | 62.7      |
| Continuous (3x441–480 V) [A]  | 10.8      | 12.6      | 17         | 19         | 25.2       | 34.8       | 41.5       | 55.8      |
| Intermittent (3x441–480 V) [A]  | 11.9      | 13.9      | 18.7       | 20.9       | 27.7       | 38.2       | 44.2       | 60.5      |
| Maximum mains fuses, see <a href="#">3.2.2.1 Recommendation of Fuses and Circuit Breakers</a> . |           |           |            |            |            |            |            |           |
| Estimated power loss [W] <sup>(1)</sup>   | 104       | 159       | 248        | 243        | 306        | 412        | 475        | 733       |
| Weight enclosure protection rating IP20 [kg (lb)]   | 4.3 (9.5) | 4.5 (9.9) | 7.9 (17.4) | 9.5 (20.9) | 9.5 (20.9) | 9.5 (20.9) | 9.5 (20.9) | 24.5 (54) |
| Efficiency [%] <sup>(2)</sup>   | 98.4      | 98.2      | 98.1       | 97.8       | 97.8       | 98.1       | 98.1       | 97.8      |

<sup>1</sup> Applies to dimensioning of drive cooling. If the switching frequency is higher than the default setting, the power losses may increase. LCP and typical control card power consumptions are included. For power loss data according to EN 50598-2, refer to Danfoss [MyDrive® ecoSmart](#) website.

<sup>2</sup> Efficiency measured at nominal current. For energy efficiency class, see [6.6 Conforming Standards](#). For part load losses, see Danfoss [MyDrive® ecoSmart](#) website.

## 6.2 Mains Supply (L1, L2, L3)

|  |   |
|--|---|
| Supply voltage                                       | 200–240 V ±10%                              |
| Supply voltage                                       | 380–480 V ±10%                              |
| Supply frequency                                     | 50/60 Hz                                    |
| Maximum imbalance temporary between mains phases     | 3.0% of rated supply voltage                |
| True power factor ( $\lambda$ )                      | ≥0.9 nominal at rated load                  |
| Displacement power factor ( $\cos\phi$ ) near unity  | (>0.98)                                     |
| Switching on the input supply L1, L2, L3 (power-ups) | Maximum 2 times/minute                      |
| Environment according to EN 60664-1                  | Overvoltage category III/pollution degree 2 |

The unit is suitable for use on a circuit capable of delivering not more than 100000  $A_{rms}$  symmetrical Amperes, 240/480 V maximum.

## 6.3 Compressor Output (U, V, W)

|  |                          |
|--|--------------------------|
| Output voltage                         | 0–100% of supply voltage |
| Output frequency (U/f)                 | 0–400 Hz                 |
| Output frequency (VVC+) <sup>(1)</sup> | 0–200 Hz                 |
| Output frequency (VVC+) <sup>(2)</sup> | 0–400 Hz                 |
| Switching on output                    | Unlimited                |
| Ramp times                             | 0.05–3600 s              |

<sup>1</sup> VVC+ combined with induction motor type.

<sup>2</sup> VVC+ combined with permanent magnet motor type.

## 6.4 Control Input/Output

### 6.4.1 10 V DC Output

|                 |               |
|-----------------|---------------|
| Terminal number | 50            |
| Output voltage  | 10.5 V ±0.5 V |
| Maximum load    | 25 mA         |

The 10 V DC output is galvanically isolated from the supply voltage (PELV) and other high-voltage terminals.

### 6.4.2 24 V DC Output

|                 |       |
|-----------------|-------|
| Terminal number | 12    |
| Maximum load    | 80 mA |

The 24 V DC output is galvanically isolated from the supply voltage (PELV) and other high-voltage terminals.

### 6.4.3 Analog Inputs

|                                  |   |
|----------------------------------|---|
| Number of analog inputs          | 2   |
| Terminal number                  | 53, 54  |
| Terminal 53 mode                 | <i>Parameter 6-61 Terminal 53 Setting: 1=voltage, 0=current</i> |
| Terminal 54 mode                 | <i>Parameter 6-63 Terminal 54 Setting: 1=voltage, 0=current</i> |
| Voltage level                    | 0–10 V  |
| Input resistance, R <sub>i</sub> | Approximately 10 kΩ   |
| Maximum voltage                  | 20 V  |
| Current level                    | 0/4–20 mA (scalable)  |
| Input resistance, R <sub>i</sub> | <500 Ω  |
| Maximum current                  | 29 mA   |
| Resolution on analog input       | 10 bit  |

The analog inputs are galvanically isolated from the supply voltage (PELV) and other high-voltage terminals.

### 6.4.4 Analog Outputs

|   |                                   |
|---|-----------------------------------|
| Number of programmable analog outputs     | 2                                 |
| Terminal number                           | 42, 45 <sup>(1)</sup>             |
| Current range at analog output            | 0/4–20 mA                         |
| The load resistor to common at analog out | 500 Ω                             |
| Maximum voltage at analog output          | 17 V                              |
| Accuracy on analog output                 | Maximum error: 0.4% of full scale |

|                             |        |
|-----------------------------|--------|
| Resolution on analog output | 10 bit |
|-----------------------------|--------|

<sup>1</sup> Terminals 42 and 45 can also be programmed as digital outputs.

The analog outputs are galvanically isolated from the supply voltage (PELV) and other high-voltage terminals.

### 6.4.5 Digital Inputs

|                                      |  |
|--------------------------------------|--|
| Programmable digital inputs          | 4  |
| Terminal number                      | 18, 19, 27, 29   |
| Logic                                | PNP or NPN   |
| Voltage level                        | 0–24 V DC  |
| Voltage level, logic 0 PNP           | <5 V DC  |
| Voltage level, logic 1 PNP           | >10 V DC   |
| Voltage level, logic 0 NPN           | >19 V DC   |
| Voltage level, logic 1 NPN           | <14 V DC   |
| Maximum voltage on input             | 28 V DC  |
| Input resistance, $R_i$              | Approximately 4 k $\Omega$                               |
| Digital input 29 as thermistor input | Fault: >2.9 k $\Omega$ and no fault: <800 $\Omega$       |
| Digital input 29 as pulse input      | Maximum frequency 32 kHz push-pull-driven & 5 kHz (O.C.) |

The digital inputs are galvanically isolated from the supply voltage (PELV) and other high-voltage terminals.

### 6.4.6 Digital Outputs

|  |                       |
|--|-----------------------|
| Number of digital outputs                | 2                     |
| <b>Terminals 42 and 45</b>               |                       |
| Terminal number                          | 42, 45 <sup>(1)</sup> |
| Voltage level at digital output          | 17 V                  |
| Maximum output current at digital output | 20 mA                 |
| The load resistor at digital output      | 1 k $\Omega$          |

<sup>1</sup> Terminals 42 and 45 can also be programmed as analog output.

The digital outputs are galvanically isolated from the supply voltage (PELV) and other high-voltage terminals.

### 6.4.7 Relay Outputs, Enclosure Sizes H3–H5

|  |  |
|--|--|
| Programmable relay output  | 2  |
| Relay 01 and 02  | 01–03 (NC), 01–02 (NO), 04–06 (NC), 04–05 (NO) |
| Maximum terminal load (AC-1) <sup>(1)</sup> on 01–02/04–05 (NO) (Resistive load)                   | 250 V AC, 3 A                                  |
| Maximum terminal load (AC-15) <sup>(1)</sup> on 01–02/04–05 (NO) (Inductive load @ $\cos\phi$ 0.4) | 250 V AC, 0.2 A                                |
| Maximum terminal load (DC-1) <sup>(1)</sup> on 01–02/04–05 (NO) (Resistive load)                   | 30 V DC, 2 A                                   |
| Maximum terminal load (DC-13) <sup>(1)</sup> on 01–02/04–05 (NO) (Inductive load)                  | 24 V DC, 0.1 A                                 |
| Maximum terminal load (AC-1) <sup>(1)</sup> on 01–03/04–06 (NC) (Resistive load)                   | 250 V AC, 3 A                                  |
| Maximum terminal load (AC-15) <sup>(1)</sup> on 01–03/04–06 (NC) (Inductive load @ $\cos\phi$ 0.4) | 250 V AC, 0.2 A                                |
| Maximum terminal load (DC-1) <sup>(1)</sup> on 01–03/04–06 (NC) (Resistive load)                   | 30 V DC, 2 A                                   |
| Minimum terminal load on 01–03 (NC), 01–02 (NO)  | 24 V DC 10 mA, 24 V AC 20 mA                   |

Environment according to EN 60664-1

Overvoltage category III/pollution degree 2

<sup>1</sup> IEC 60947 parts 4 and 5. Endurance of the relay varies with different load type, switching current, ambient temperature, drive configuration, working profile, and so forth. Mount a snubber circuit when connecting inductive loads to the relays.

The relay outputs are galvanically isolated from the supply voltage (PELV) and other high-voltage terminals.

## 6.4.8 Relay Outputs, Enclosure Size H6

|  |  |
|--|--|
| Programmable relay output  | 2  |
| Relay 01 and 02  | 01–03 (NC), 01–02 (NO), 04–06 (NC), 04–05 (NO) |
| Maximum terminal load (AC-1) <sup>(1)</sup> on 04–05 (NO) (Resistive load) <sup>(2)</sup><br>(3) | 400 V AC, 2 A                                  |
| Maximum terminal load (AC-15) <sup>(1)</sup> on 04–05 (NO) (Inductive load<br>@ cosφ 0.4)        | 240 V AC, 0.2 A                                |
| Maximum terminal load (DC-1) <sup>(1)</sup> on 04–05 (NO) (Resistive load)                       | 80 V DC, 2 A                                   |
| Maximum terminal load (DC-13) <sup>(1)</sup> on 04–05 (NO) (Inductive load)                      | 24 V DC, 0.1 A                                 |
| Maximum terminal load (AC-1) <sup>(1)</sup> on 04–06 (NC) (Resistive load)                       | 240 V AC, 4 A                                  |
| Maximum terminal load (AC-15) <sup>(1)</sup> on 04–06 (NC) (Inductive load<br>@ cosφ 0.4)        | 240 V AC, 0.2 A                                |
| Maximum terminal load (DC-1) <sup>(1)</sup> on 04–06 (NC) (Resistive load)                       | 50 V DC, 2 A                                   |
| Maximum terminal load (DC-13) <sup>(1)</sup> on 04–06 (NC) (Inductive load)                      | 24 V DC, 0.1 A                                 |
| Minimum terminal load on 01–03 (NC), 01–02 (NO), 04–06 (NC),<br>04–05 (NO)                       | 24 V DC 10 mA, 24 V AC 20 mA                   |
| Environment according to EN 60664-1  | Overvoltage category III/pollution degree 2    |

<sup>1</sup> IEC 60947 parts 4 and 5. Endurance of the relay varies with different load type, switching current, ambient temperature, drive configuration, working profile, and so forth. Mount a snubber circuit when connecting inductive loads to the relays.

<sup>2</sup> Overvoltage Category II.

<sup>3</sup> UL applications 250 V AC, 3 A.

The relay outputs are galvanically isolated from the supply voltage (PELV) and other high-voltage terminals.

## 6.4.9 RS485 Serial Communication

|                 |                                    |
|-----------------|------------------------------------|
| Terminal number | 68 (P, TX+, RX+), 69 (N, TX-, RX-) |
| Terminal number | 61 common for terminals 68 and 69  |

The RS485 serial communication outputs are galvanically isolated from the supply voltage (PELV) and other high-voltage terminals.

## 6.5 Ambient Conditions

|  |  |
|--|--|
| Enclosure protection rating  | IP20   |
| Enclosure kit available  | IP21, TYPE 1   |
| Maximum vibration exposure   | 1.0 g  |
| Maximum relative humidity  | 5–95% (IEC 60721-3-3; Class 3K3 (non-condensing) during operation) |
| Aggressive environment (IEC 60721-3-3), coated (standard), enclosure sizes H3–H5 | Class 3C3  |
| Aggressive environment (IEC 60721-3-3), non-coated enclosure size H6             | Class 3C2  |
| Environmental testing (IEC 60068-2-43 H2S)                                       | 10 days  |
| Ambient temperature, enclosure sizes H3–H5, 6–10 kW/8–15 hp <sup>(1)</sup>       | 50 °C (122 °F)   |
| Ambient temperature, enclosure size H5, 18–22 kW/25–30 hp <sup>(1)</sup>         | 52 °C (125.6 °F)   |
| Ambient temperature, enclosure size H6, 30 kW/40 hp <sup>(1)</sup>               | 45 °C (113 °F)   |
| Minimum ambient temperature during full-scale operation                          | 0 °C (32 °F)   |

|  |                                       |
|--|---------------------------------------|
| Minimum ambient temperature at reduced performance, enclosure sizes H3–H5                                  | -20 °C (-4 °F)                        |
| Minimum ambient temperature at reduced performance, enclosure size H6                                      | -10 °C (14 °F)                        |
| Temperature during storage/transport   | -30 to +65/70 °C (-22 to +149/158 °F) |
| Maximum altitude above sea level without derating  | 1000 m (3281 ft)                      |
| Maximum altitude above sea level with derating   | 3000 m (9843 ft)                      |
| Derating for high altitude, see <a href="#">3.1.2.2 Derating for Low Air Pressure and High Altitudes</a> . |                                       |

<sup>1</sup> Refer to [3.1 Mechanical Installation](#).

## 6.6 Conforming Standards

|  |   |
|--|---|
| Safety standards                       | EN/IEC 61800-5-1, UL 508C, EN/IEC/UL 60730-1  |
| EMC standards, Emission                | EN 61800-3, EN 61000-6-3/4, EN 55011, IEC 61800-3   |
| EMC standards, Immunity                | EN 61800-3, EN 61000-3-12, EN 61000-6-1/2, EN 61000-4-2, EN 61000-4-3, EN 61000-4-4, EN 61000-4-5, EN 61000-4-6 |
| Energy efficiency class <sup>(1)</sup> | IE2   |

<sup>1</sup> Determined according to EN 50598-2 at:

- Rated load.
- 90% rated frequency.
- Switching frequency factory setting.
- Switching pattern factory setting.
- For power loss data according to EN 50598-2, refer to Danfoss [MyDrive® ecoSmart](#) website.

## NOTICE

The VLT® Compressor Drive CDS 803 with SXXX in the type code is certified against UL 508C/EN61800-5-1. Example:

CDS803P7K5T4E20H4XXCXXXSXXXXAXBXCXXXXDX

The VLT® Compressor Drive CDS 803 with S129 in the type code is certified against EN/IEC 60730-1. Example:

CDS803P15KT4E20H2XXCXXXS129XAXBXCXXXXDX

The VLT® Compressor Drive CDS 803 with S096 in the type code is certified against UL/EN/IEC 60730-1. Example:

CDS803P30KT4E20H2XXXXXXS096XAXBXCXXXXDX

## 6.7 Cable Lengths and Cross-sections

|  |   |
|--|---|
| Maximum compressor cable length, shielded/armored (EMC-correct installation) | See <i>EMC Emission Test Results</i> in the VLT® Compressor Drive Design Guide listed in <a href="#">1.2 Additional Resources</a> . |
| Maximum compressor cable length, unshielded/unarmoured                       | 50 m (164 ft)   |
| Maximum cross-section to compressor, mains                                   | See <a href="#">6.1 Electrical Data</a> for more information  |
| Cross-section DC terminals for filter feedback on enclosure size H3          | 4 mm <sup>2</sup> /11 AWG   |
| Cross-section DC terminals for filter feedback on enclosure sizes H4–H6      | 16 mm <sup>2</sup> /6 AWG   |
| Maximum cross-section to control terminals, rigid wire                       | 2.5 mm <sup>2</sup> /14 AWG   |
| Maximum cross-section to control terminals, flexible wire                    | 2.5 mm <sup>2</sup> /14 AWG   |
| Minimum cross-section to control terminals                                   | 0.05 mm <sup>2</sup> /30 AWG  |

## 6.8 Acoustic Noise

Acoustic noise from the drives comes from 3 sources:

- DC-link coils
- Integral fan
- RFI filter inductor

Table 14: Typical Values Measured at a Distance of 1 m (3.28 ft) from the Unit

| Enclosure | Level [dBA] <sup>(1)</sup> |
|-----------|----------------------------|
| H3        | 53.8                       |
| H4        | 64                         |
| H5        | 63.7                       |
| H6        | 71.5                       |

<sup>1</sup> The values are measured under the background of 35 dBA noise and the fan running at full speed.

## 6.9 Shipping Dimensions

Table 15: Shipping Dimensions

| Enclosure size | 200–240 V AC [kW (hp)] | 380–480 V AC [kW (hp)] | IP rating | Maximum weight [kg (lb)] | Height [mm (in)] | Width [mm (in)] | Depth [mm (in)] |
|----------------|------------------------|------------------------|-----------|--------------------------|------------------|-----------------|-----------------|
| H3             | –                      | 6.0–7.5 (8.0–10)       | IP20      | 4.5 (9.9)                | 280 (11)         | 155 (6.1)       | 320 (12.6)      |
| H4             | 6.0–7.5 (8.0–10)       | 10 (15)                | IP20      | 7.9 (17.4)               | 380 (15)         | 200 (7.9)       | 315 (12.4)      |
| H5             | 10 (15)                | 11–22 (15–30)          | IP20      | 9.5 (20.9)               | 395 (15.6)       | 233 (9.2)       | 380 (15)        |
| H6             | –                      | 30 (40)                | IP20      | 24.5 (54.0)              | 850 (33.5)       | 370 (15.6)      | 460 (18.1)      |

## 6.10 Accessories and Spare Parts

Refer to the VLT® Compressor Drive CDS 803 Design Guide listed in [1.2 Additional Resources](#).



## 7 Appendix

### 7.1 Abbreviations

|               |  |
|---------------|--|
| °C            | Degrees Celsius                            |
| °F            | Degrees Fahrenheit                         |
| A             | Ampere/AMP                                 |
| AC            | Alternating current                        |
| AMA           | Automatic motor adaptation                 |
| AWG           | American wire gauge                        |
| DC            | Direct current                             |
| EMC           | Electro-magnetic compatibility             |
| ETR           | Electronic thermal relay                   |
| $f_{M,N}$     | Nominal motor frequency                    |
| hp            | Horsepower                                 |
| Hz            | Hertz                                      |
| $I_{INV}$     | Rated inverter output current              |
| $I_{LIM}$     | Current limit                              |
| $I_{M,N}$     | Nominal motor current                      |
| $I_{VLT,MAX}$ | Maximum output current                     |
| $I_{VLT,N}$   | Rated output current supplied by the drive |
| kg            | Kilogram                                   |
| kHz           | Kilohertz                                  |
| kW            | Kilowatt                                   |
| LCP           | Local control panel                        |
| m             | Meter                                      |
| mA            | Milliampere                                |
| MCT           | Motion Control Tool                        |
| Nm            | Newton meter                               |
| $n_s$         | Synchronous motor speed                    |
| $P_{M,N}$     | Nominal motor power                        |
| PELV          | Protective extra low voltage               |
| RPM           | Revolutions per minute                     |
| s             | Second                                     |

|           |                       |
|-----------|-----------------------|
| $T_{LIM}$ | Torque limit          |
| $U_{M,N}$ | Nominal motor voltage |
| V         | Volts                 |

## 7.2 Conventions

- Numbered lists indicate procedures.
- Bulleted and dashed lists indicate listings of other information where the order of the information is not relevant.
- Bolded text indicates highlighting and section headings.
- Italicized text indicates the following:
  - Cross-reference.
  - Link.
  - Footnote.
  - Parameter name.
  - Parameter option.
  - Parameter group name.
  - Alarms/warnings.
- All dimensions in drawings are in metric values (imperial values in brackets).
- An asterisk (\*) indicates the default setting of a parameter.

## Index

|                                   |        |                                      |            |
|-----------------------------------|--------|--------------------------------------|------------|
| <b>A</b>                          |        | Local control panel.....             | 26         |
| Abbreviations.....                | 41     | Low air pressure.....                | 14         |
| Acoustic noise.....               | 30, 39 | <b>M</b>                             |            |
| Alarms.....                       | 30     | Main menu.....                       | 27         |
| Alarms, overview.....             | 31     | Mains supply (L1, L2, L3).....       | 35         |
| Ambient conditions.....           | 38     | Maximum altitude.....                | 39         |
| Ambient temperature.....          | 14, 38 | <b>O</b>                             |            |
| Analog input.....                 | 36     | Output current.....                  | 34, 35     |
| Analog output.....                | 36     | Output frequency.....                | 36, 36     |
| Approvals and certifications..... | 6      | Output voltage.....                  | 36         |
| <b>C</b>                          |        | <b>P</b>                             |            |
| Cable cross-section.....          | 39     | PC tool, download.....               | 6          |
| Cable length.....                 | 39     | Programming.....                     | 26         |
| Cable requirements.....           | 14     | Programming interfaces.....          | 26         |
| Circuit breakers.....             | 15     | <b>Q</b>                             |            |
| Compressor output (U, V, W).....  | 36     | Qualified personnel.....             | 6, 12      |
| Control input/output.....         | 36, 36 | Quick menu.....                      | 27         |
| Control terminals.....            | 20     | <b>R</b>                             |            |
| Conventions.....                  | 42     | Ramp times.....                      | 36         |
| Cooling clearance.....            | 14     | Relay outputs.....                   | 37, 38     |
| <b>D</b>                          |        | Relay terminals.....                 | 19         |
| Data storage.....                 | 28     | Reset/restart operation.....         | 30         |
| DC voltage output, 10 V.....      | 36     | RS485.....                           | 21, 21, 38 |
| DC voltage output, 24 V.....      | 36     | <b>S</b>                             |            |
| Default settings.....             | 28     | Shipping dimensions.....             | 40         |
| Derating.....                     | 14, 14 | Side-by-side installation.....       | 14         |
| Digital input.....                | 37     | Software version.....                | 6          |
| Digital output.....               | 37     | Standards                            |            |
| Discharge time.....               | 13     | EN 50598-2.....                      | 34,35      |
| <b>E</b>                          |        | EN 60664-1.....                      | 35         |
| Electrical data.....              | 34, 34 | IEC 60721-3-3.....                   | 38         |
| Electrical installation.....      | 14     | IEC 60068-2-43 H2S.....              | 38         |
| EMC-compliant installation.....   | 22     | UL Safety standards.....             | 39         |
| Energy efficiency                 |        | EMC standards, emission.....         | 39         |
| Power loss data.....              | 34,35  | EMC standards, immunity.....         | 39         |
| Class.....                        | 39     | Storage.....                         | 39         |
| <b>F</b>                          |        | Store data.....                      | 28         |
| Factory settings.....             | 28     | Supplementary documentation.....     | 6          |
| Fastener torque ratings.....      | 14     | Supply frequency.....                | 35         |
| Fuses.....                        | 15     | Supply voltage.....                  | 35         |
| <b>H</b>                          |        | Switching frequency.....             | 14         |
| High altitudes.....               | 14     | Symbols.....                         | 12         |
| <b>I</b>                          |        | <b>T</b>                             |            |
| Indicator light.....              | 27, 27 | Terminal overview.....               | 20         |
| Input current                     |        | Transport.....                       | 39         |
| Maximum input current.....        | 34,35  | True power factor.....               | 35         |
| Installation                      |        | <b>V</b>                             |            |
| Qualified personnel.....          | 12     | Vibration.....                       | 30, 39     |
| Start up.....                     | 29     | VLT® Motion Control Tool MCT 10..... | 6, 26      |
| <b>L</b>                          |        | Voltage                              |            |
| Leakage current.....              | 13     |                                      |            |

---

|                     |    |                         |    |
|---------------------|----|-------------------------|----|
| Safety warning..... | 12 | Warnings, overview..... | 31 |
|                     |    | Website.....            | 6  |
|                     |    | Wiring schematic.....   | 15 |
| <b>W</b>            |    |                         |    |
| Warnings.....       | 30 |                         |    |

## VLT Drives Glossary - CDS 803

### A

**Analog reference**

A signal transmitted to the analog inputs 53 or 54 (voltage or current).

- Current input: 0–20 mA and 4–20 mA
- Voltage input: 0–10 V DC

**Analog inputs**

The analog inputs are used for controlling various functions of the drive.  
 There are 2 types of analog inputs:  
 Current input, 0–20 mA, and 4–20 mA  
 Voltage input, 0 V DC to +10 V DC

**Analog outputs**

The analog outputs can supply a signal of 0–20 mA, 4–20 mA.

### B

**Breakaway torque**

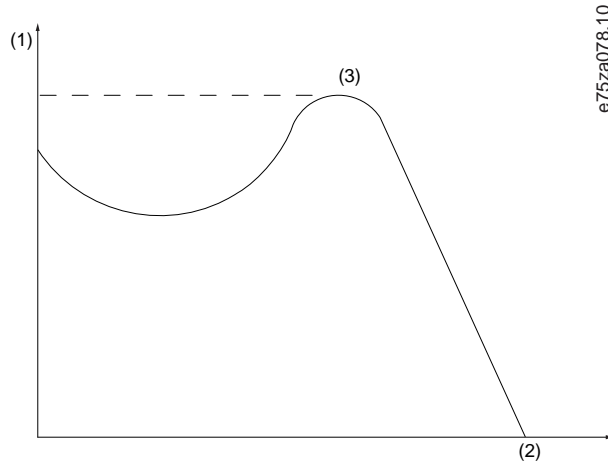

**Bus reference**

A signal transmitted to the serial communication port (FC port).

### C

**Control command**

Functions are divided into 2 groups.  
 Functions in group 1 have higher priority than functions in group 2.

|         |   |
|---------|---|
| Group 1 | Reset, coast stop, reset and coast stop, quick stop, DC brake, stop, the [OFF] key. |
| Group 2 | Start, pulse start, reversing, start reversing, jog, freeze output.                 |

### D

**Digital inputs**

The digital inputs can be used for controlling various functions of the drive.

**Digital outputs**

The drive features 2 solid-state outputs that can supply a 24 V DC (maximum 40 mA) signal.

### F

**$f_M$**

Motor frequency.

**$f_{M,N}$**

Rated motor frequency (nameplate data).

**$f_{MAX}$**

Maximum compressor frequency.

|                                  |  |
|----------------------------------|--|
| $f_{\text{MIN}}$                 | Minimum compressor frequency.  |
| $f_{\text{jog}}$                 | Motor frequency when the jog function is activated (via digital terminals).  |
| <b>I</b>                         |  |
| $I_{\text{M}}$                   | Motor current (actual).  |
| $I_{\text{M,N}}$                 | Rated motor current (nameplate data).  |
| <b>Intermittent duty cycle</b>   | An intermittent duty rating refers to a sequence of duty cycles. Each cycle consists of an on-load and an off-load period. The operation can be either periodic duty or non-periodic duty.   |
| <b>L</b>                         |  |
| <b>lsb</b>                       | Least significant bit.   |
| <b>M</b>                         |  |
| <b>MCM</b>                       | Short for "mille circular mil", an American measuring unit for cable cross-section. 1 MCM=0.5067 mm <sup>2</sup>   |
| <b>msb</b>                       | Most significant bit.  |
| <b>N</b>                         |  |
| $n_{\text{M,N}}$                 | Nominal motor speed (nameplate data).  |
| <b>O</b>                         |  |
| <b>Online/offline parameters</b> | Changes to online parameters are activated immediately after the data value is changed. Press [OK] to activate changes to off-line parameters.   |
| <b>P</b>                         |  |
| <b>PI controller</b>             | The PI controller maintains the required speed, pressure, temperature, and so on, by adjusting the output frequency to match the varying load.   |
| $P_{\text{M,N}}$                 | Rated motor power (nameplate data in kW or hp).  |
| <b>Power factor</b>              | <p>The power factor is the relation between <math>I_1</math> and <math>I_{\text{RMS}}</math></p> $\text{Power factor} = \frac{\sqrt{3 \times U \times I_1 \cos\phi}}{\sqrt{3 \times U \times I_{\text{RMS}}}}$ <p>The power factor for 3-phase control:</p> $\text{Power factor} = \frac{I_1 \times \cos\phi_1}{I_{\text{RMS}}} = \frac{I_1}{I_{\text{RMS}}} \text{ since } \cos\phi_1 = 1$ <p>The power factor indicates to which extent the drive imposes a load on the mains supply.</p> <p>The lower the power factor, the higher the <math>I_{\text{RMS}}</math> for the same kW performance.</p> $I_{\text{RMS}} = \sqrt{I_1^2 + I_5^2 + I_7^2 + \dots + I_n^2}$ <p>In addition, a high-power factor indicates that the different harmonic currents are low.</p> <p>The DC coils in the drive produce a high-power factor, which minimizes the imposed load on the mains supply.</p> |
| <b>Preset reference</b>          | A defined preset reference to be set from -100% to +100% of the reference range. Selection of 8 preset references via the digital terminals.   |

## R

### RCD

Residual-current device.

### Relay outputs

The drive features 2 programmable relay outputs.

## S

### Setup

Save parameter settings in 4 setups. Change between the 4 parameter setups and edit 1 setup, while another setup is active.

### Slip compensation

The drive compensates for the compressor slip by giving the frequency a supplement that follows the measured compressor load keeping the compressor speed almost constant.

### Start-disable command

A stop command belonging to Group 1 control commands, see the table Function Groups under *Control Command*.

### Stop command

A stop command belonging to Group 1 control commands, see the table Function Groups under *Control Command*.

## T

### Thermistor

A temperature-dependent resistor placed on the drive or the compressor.

### Trip

A state entered in fault situations, for example, if the drive is subject to an overtemperature or when the drive is protecting the compressor, process, or mechanism. The drive prevents a restart until the cause of the fault has disappeared. To cancel the trip state, restart the drive. Do not use the trip state for personal safety.

### Trip lock

The drive enters this state in fault situations to protect itself. The drive requires physical intervention, for example when there is a short circuit on the output. A trip lock can only be canceled by disconnecting mains, removing the cause of the fault, and reconnecting the drive. Restart is prevented until the trip state is canceled by activating reset or, sometimes, by being programmed to reset automatically. Do not use the trip lock state for personal safety.

## U

### $U_M$

Instant motor voltage.

### $U_{M,N}$

Rated motor voltage (nameplate data).

## V

### VT characteristics

Variable torque characteristics used for pumps and fans.

**Danfoss A/S**  
Ulsnaes 1  
DK-6300 Graasten  
[vlt-drives.danfoss.com](http://vlt-drives.danfoss.com)

---

Danfoss can accept no responsibility for possible errors in catalogs, brochures, and other printed material. Danfoss reserves the right to alter its products without notice. This also applies to products already on order provided that such alterations can be made without subsequential changes being necessary in specifications already agreed. All trademarks in this material are property of the respective companies. Danfoss and the Danfoss logotype are trademarks of Danfoss A/S. All rights reserved.

---

